



US006826983B1

(12) **United States Patent**
Magdi

(10) **Patent No.:** **US 6,826,983 B1**
(45) **Date of Patent:** **Dec. 7, 2004**

(54) **LIGHT BULB CHANGER**

(75) Inventor: **Thomas Magdi**, 888 Hamilton Ave.,
Rockledge, FL (US) 32955

(73) Assignee: **Thomas Magdi**, Rockledge, FL (US)

(*) Notice: Subject to any disclaimer, the term of this
patent is extended or adjusted under 35
U.S.C. 154(b) by 0 days.

4,314,723 A 2/1982 Vermillion
D297,499 S 9/1988 Whitney
4,901,606 A 2/1990 Christensen
5,218,889 A 6/1993 Brockberg
5,553,373 A * 9/1996 Sprayberry 81/53.11
5,692,417 A * 12/1997 Irpino 81/53.12
6,127,782 A * 10/2000 Flory et al. 315/129

* cited by examiner

Primary Examiner—Hadi Shakeri
(74) *Attorney, Agent, or Firm*—Brian S. Steinberger; Law
Offices of Brian S. Steinberger, P.A.

(21) Appl. No.: **10/361,528**

(22) Filed: **Feb. 10, 2003**

(51) **Int. Cl.**⁷ **H01K 3/32**

(52) **U.S. Cl.** **81/53.11; 81/52**

(58) **Field of Search** **81/53.1, 53.11,**
81/53.12, 54, 57.32, 57.4, 52; 340/825.36

(56) **References Cited**

U.S. PATENT DOCUMENTS

558,573 A 4/1896 Smith
898,696 A 9/1908 Southworth
1,847,953 A 3/1932 Finesey
2,637,587 A 5/1953 Robinson
3,328,592 A 6/1967 Shaw
3,473,423 A * 10/1969 Peck 81/53.12
4,068,216 A * 1/1978 Brouwer et al. 340/641

(57) **ABSTRACT**

A light bulb changer method and apparatus that contains
components that allows for instantly detecting a burned out
light, automatically removing the burned out light, and
automatically replacing the burned out light with a replace-
ment bulb. The changer operates without human
intervention, and can be assembled from a kit having a light
fixture, detecting sensor, removing and replacement hard-
ware. The kit can allow a consumer to assemble the changer
for use as a novelty item, and/or also to be used as a working
light fixture, such as a table lamp, and the like. The changer
can also be used as a retrofit for existing light fixtures so that
the existing light fixtures can be modified.

13 Claims, 17 Drawing Sheets

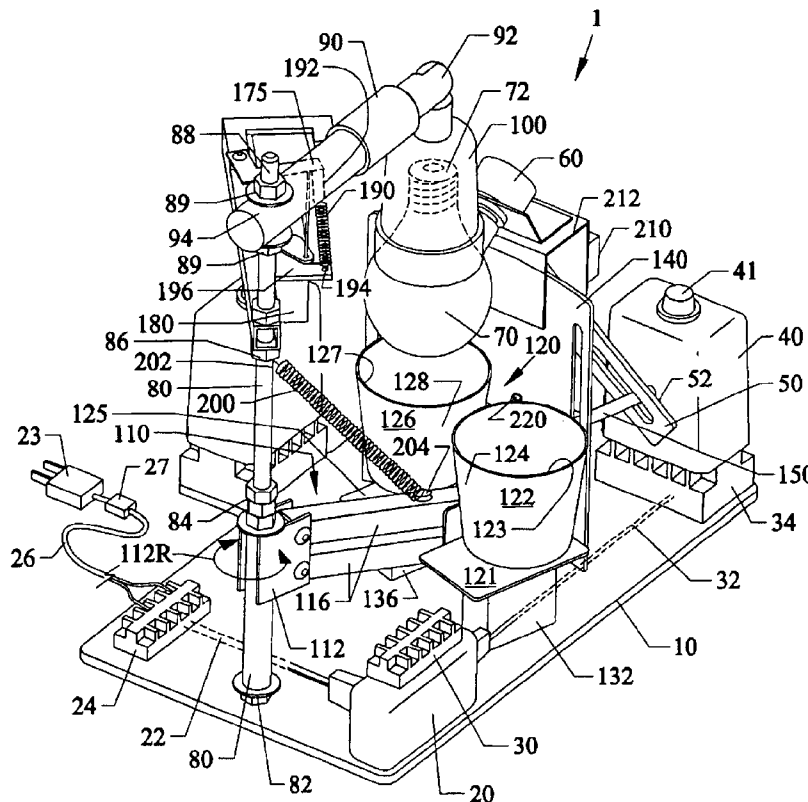

Fig.1

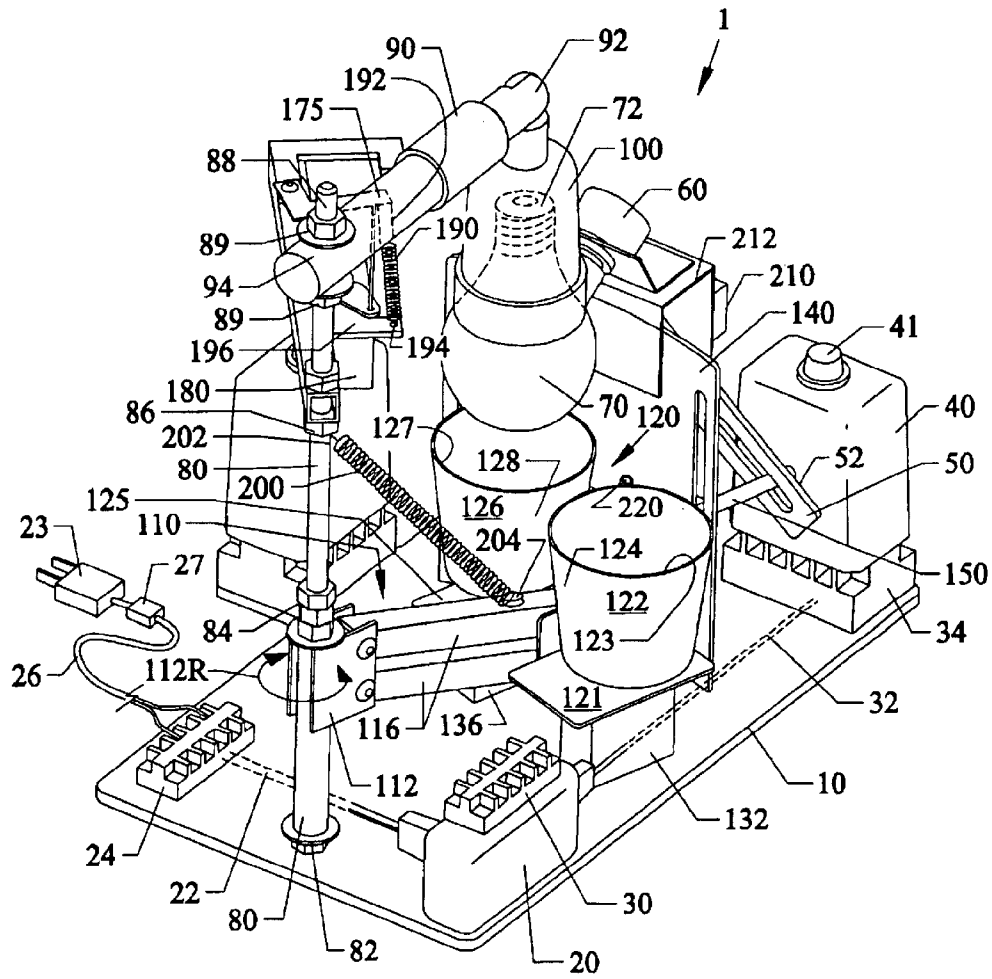

Fig.3

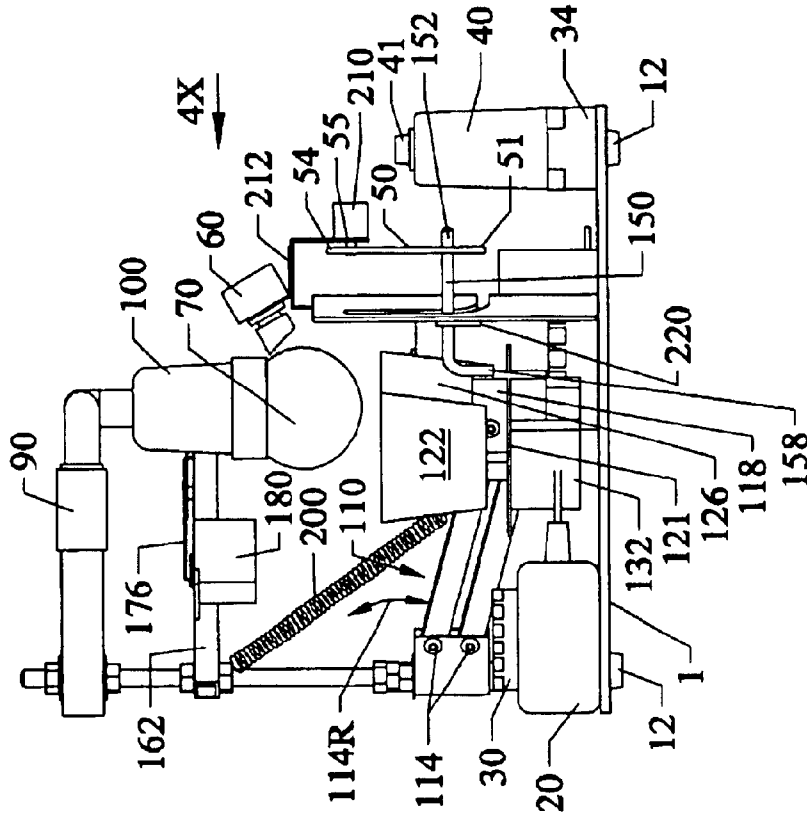

Fig.2

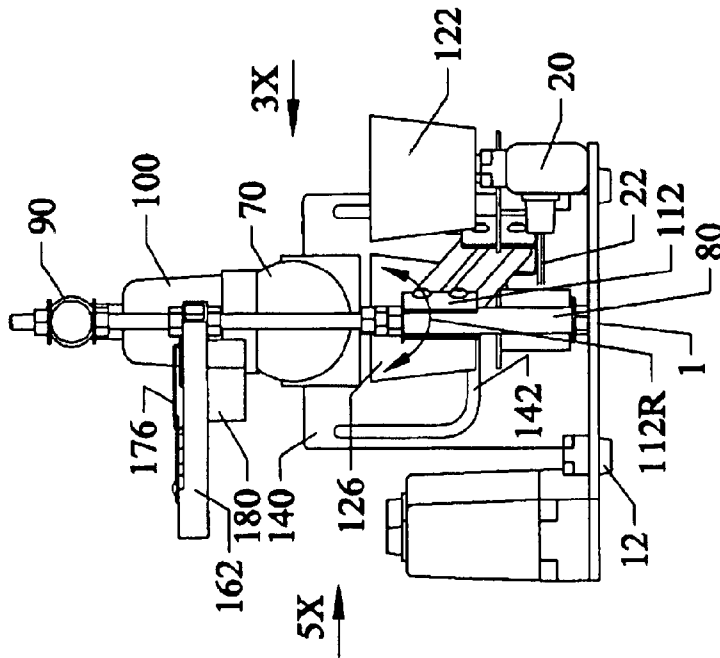

Fig.5

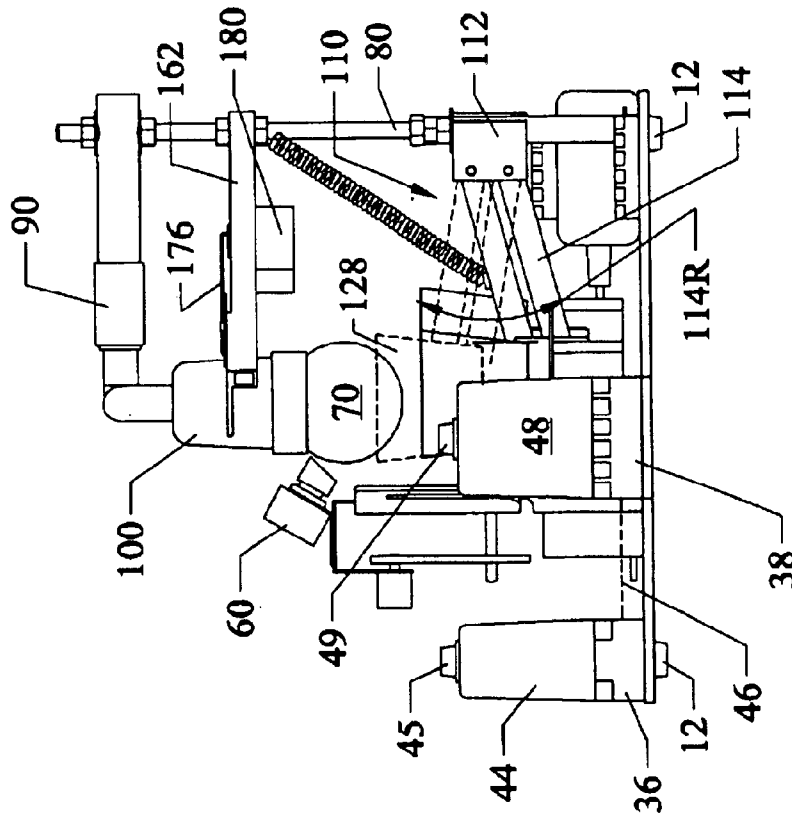

Fig.4

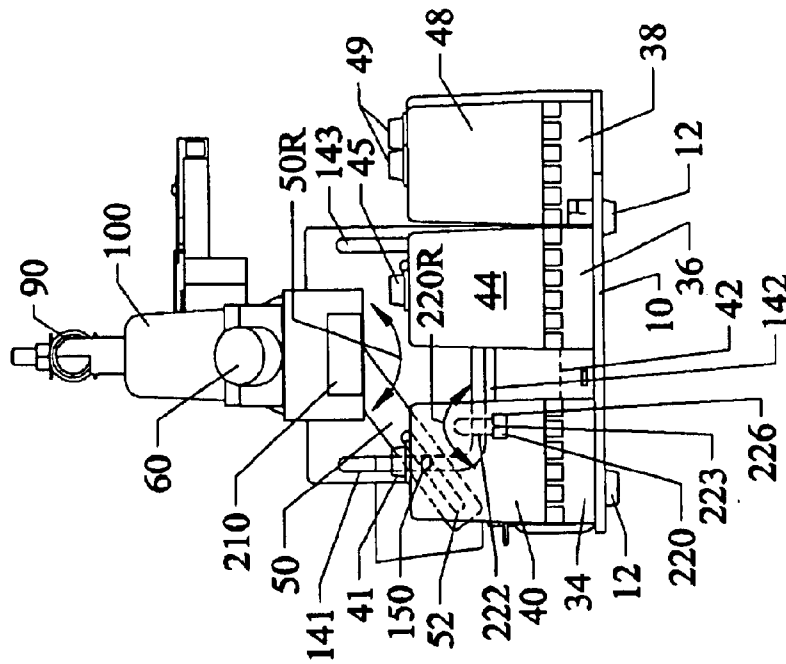

Fig. 6

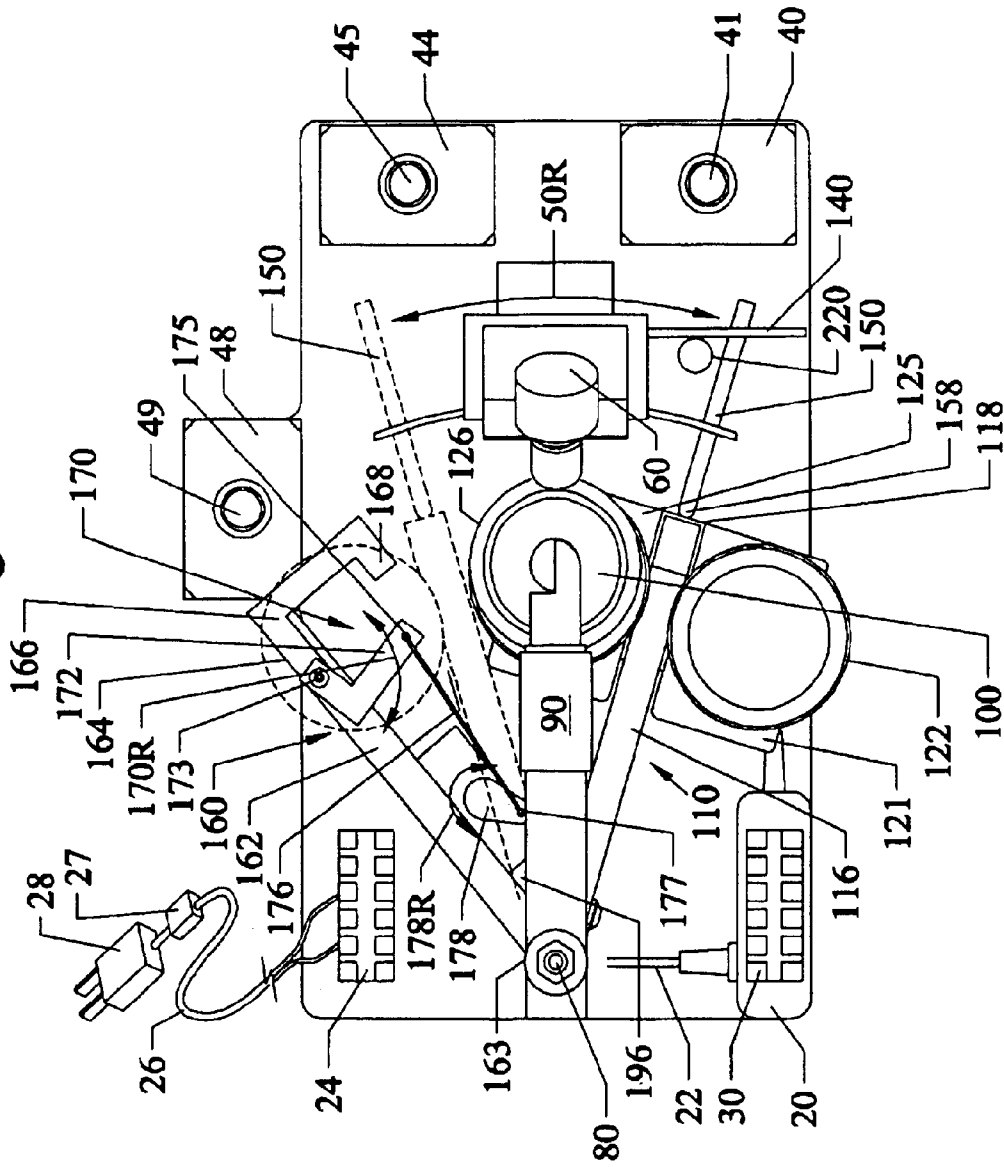

Fig. 7A

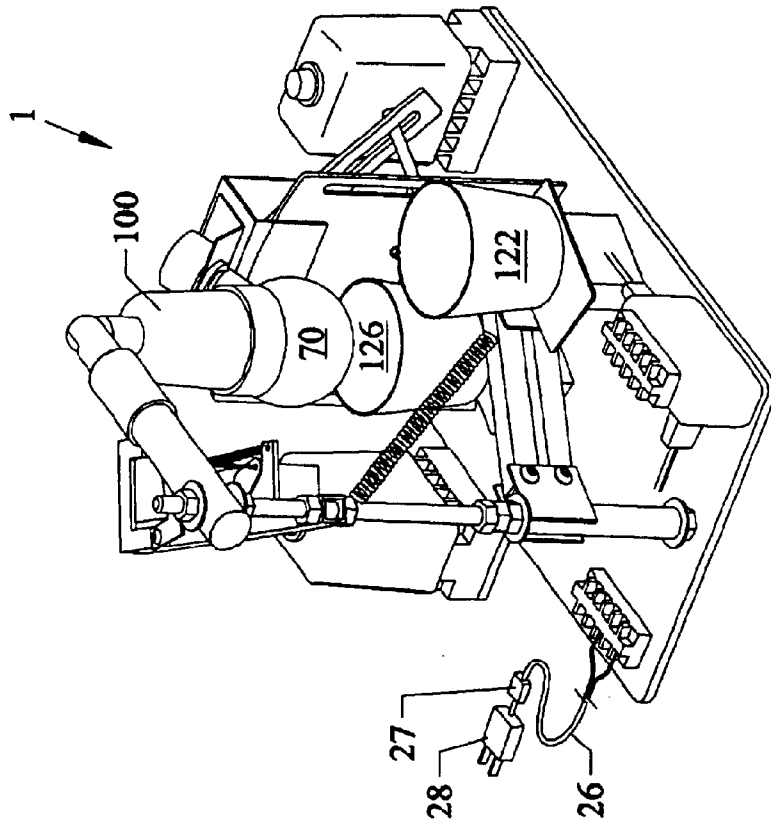

Fig. 7B

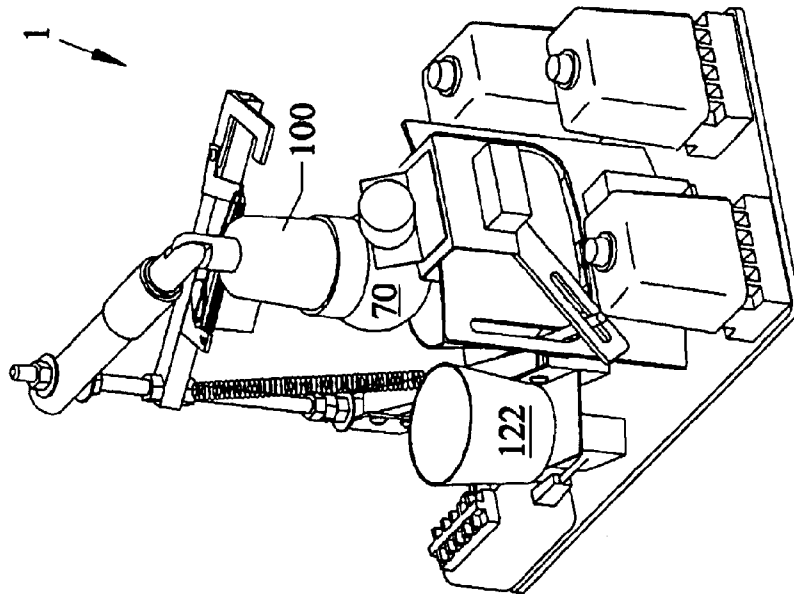

Fig.9A

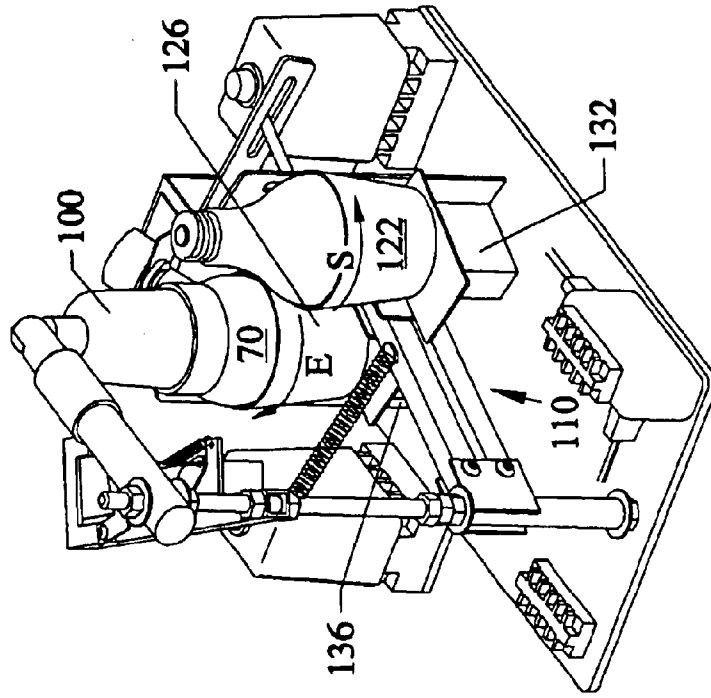

Fig.9B

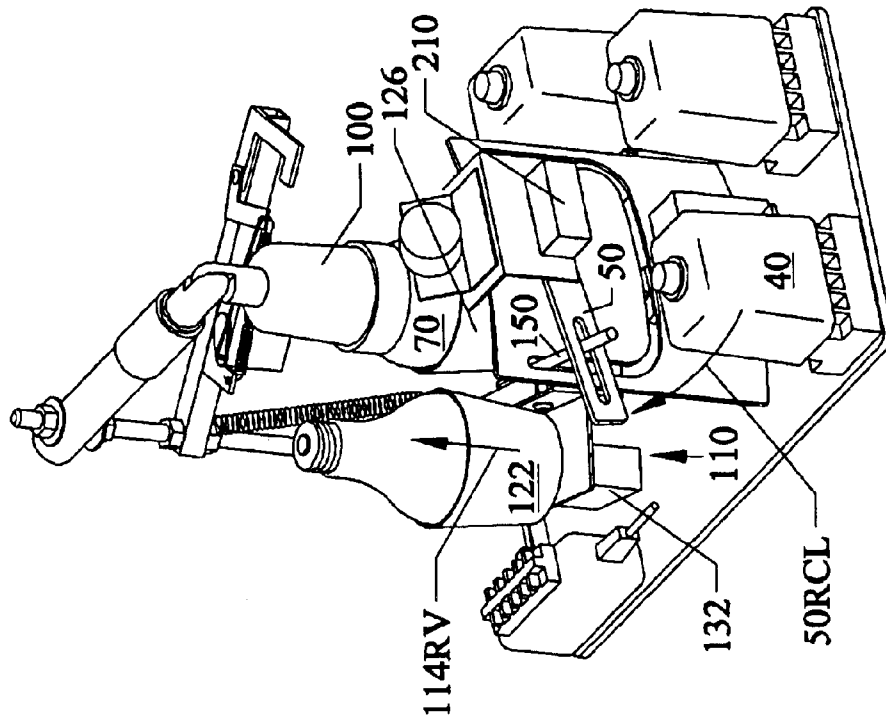

Fig. 10A

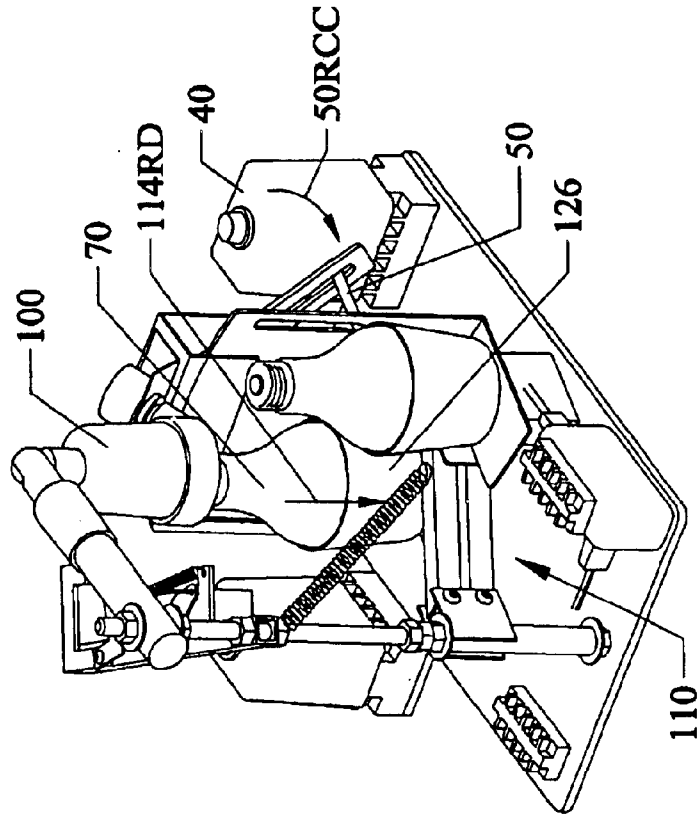

Fig. 10B

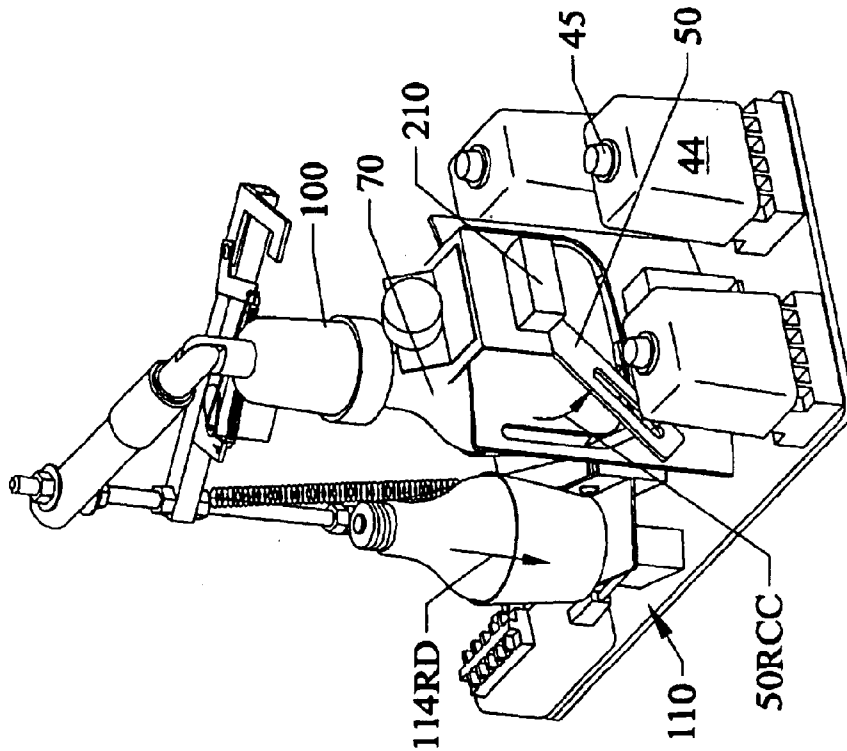

Fig. 11A

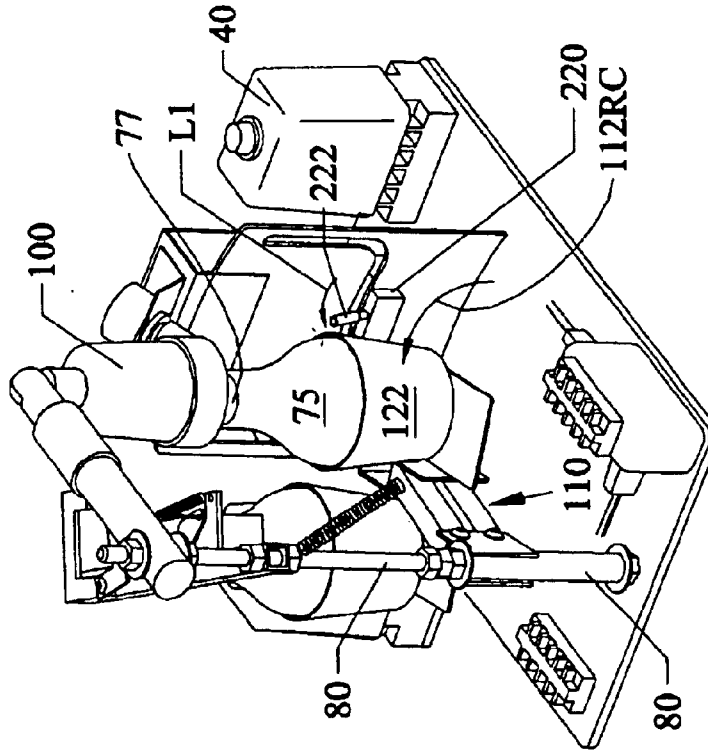

Fig. 11B

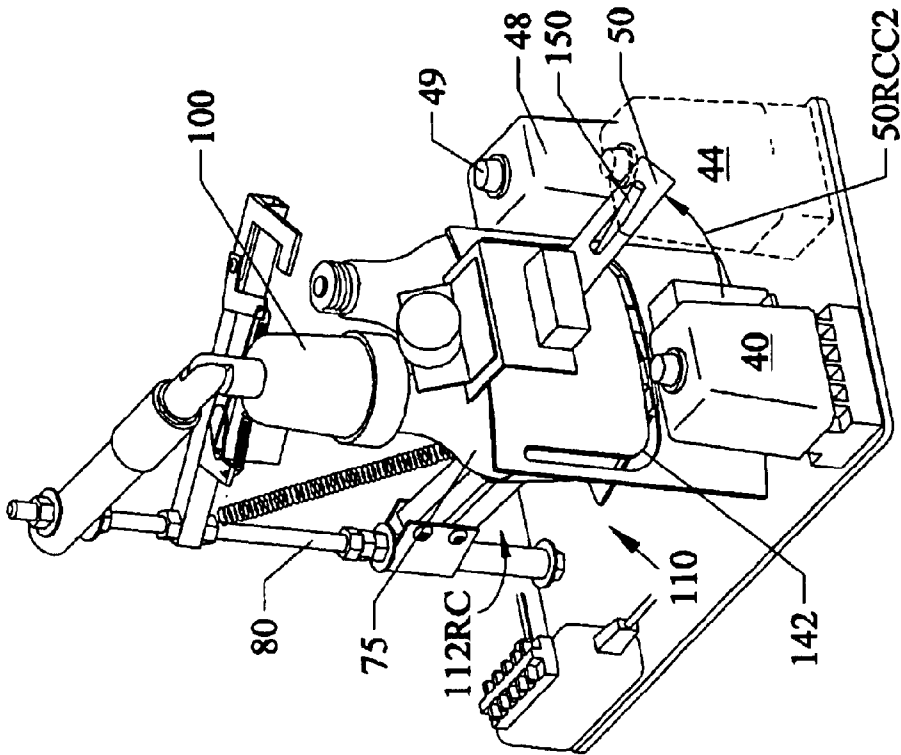

Fig.12A

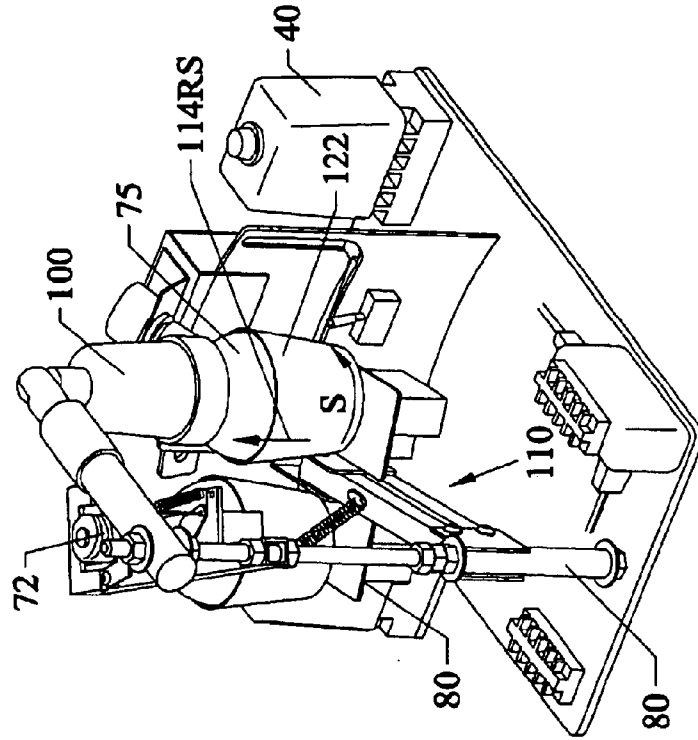

Fig.12B

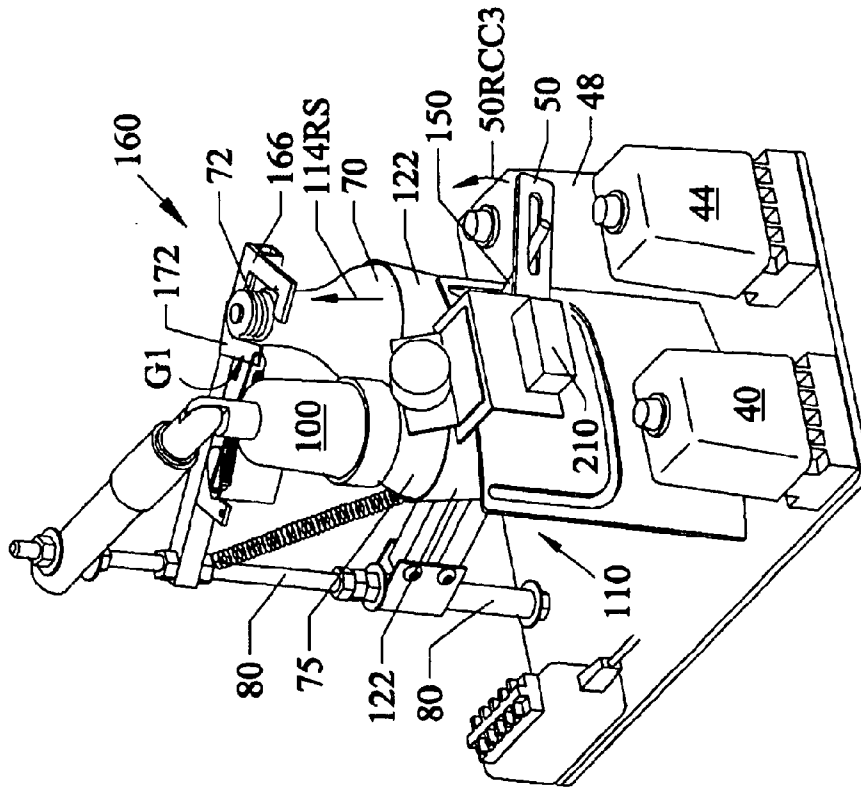

Fig.13A

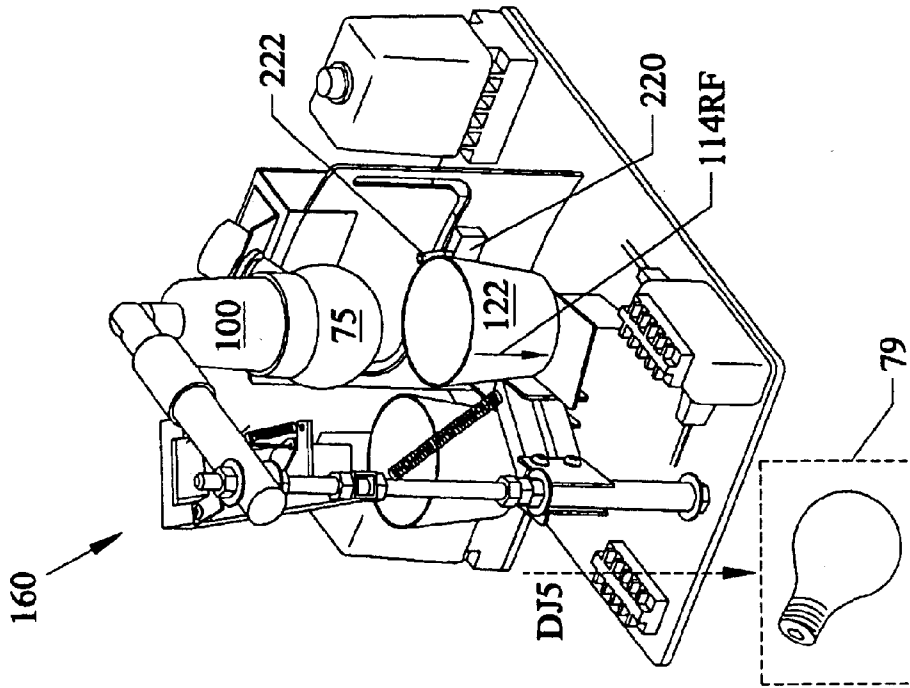

Fig.13B

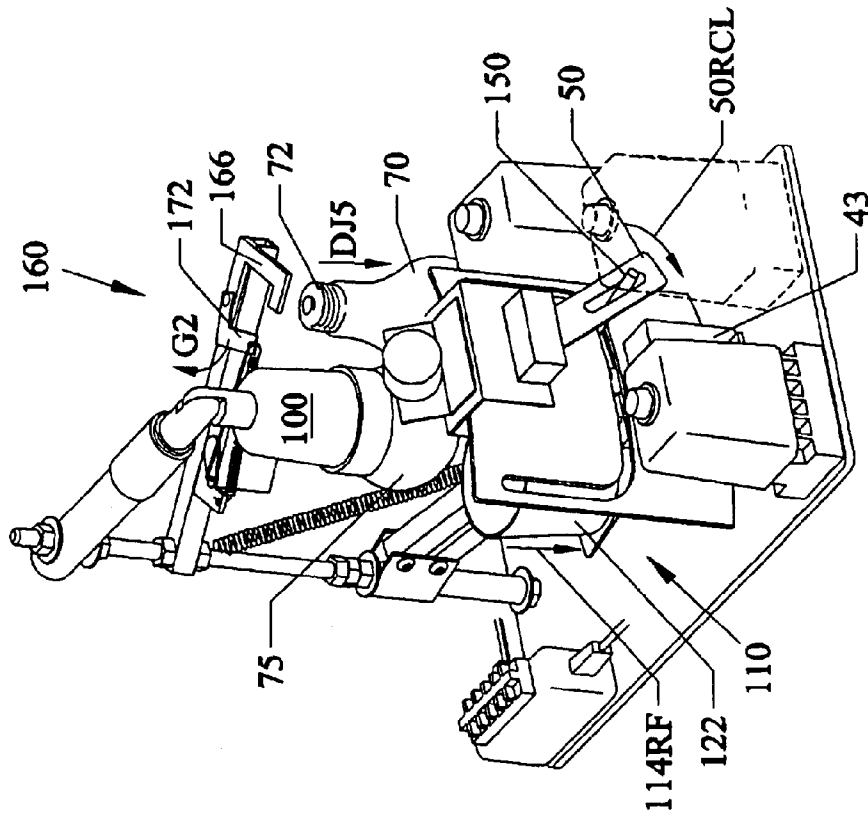

Fig. 14A

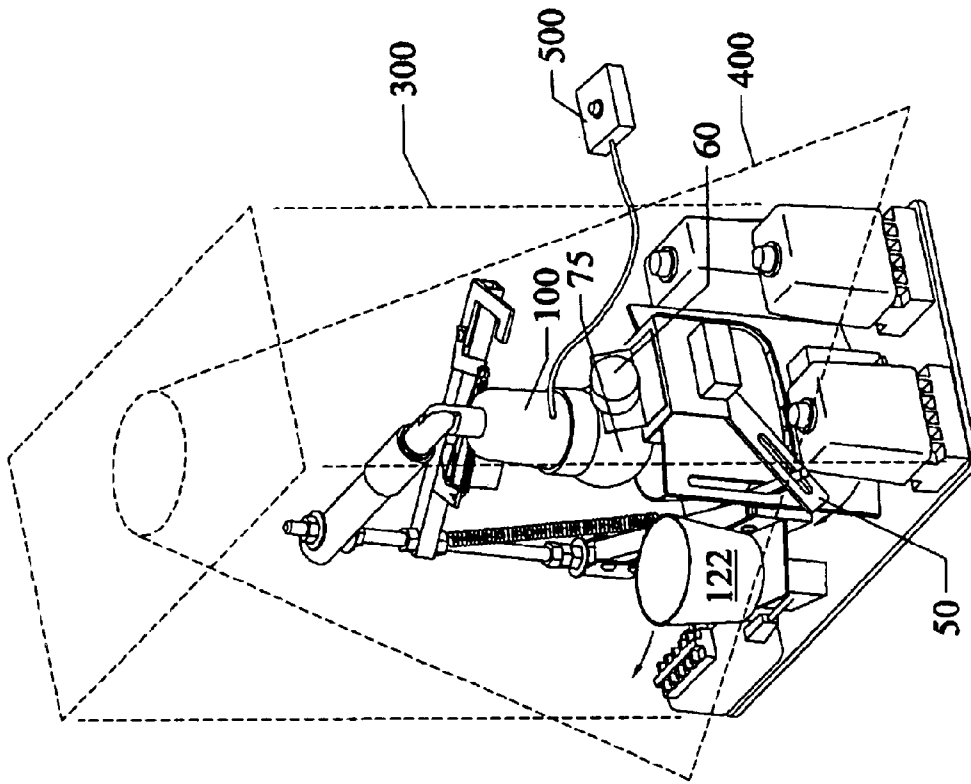
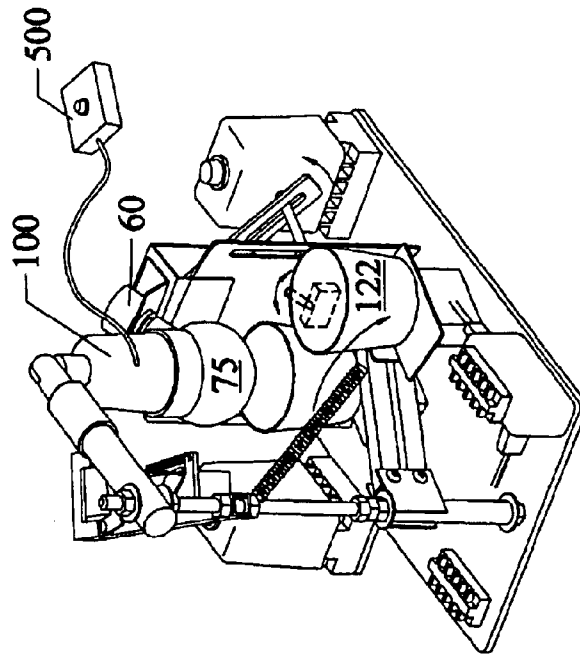

Fig. 14B

Fig.15

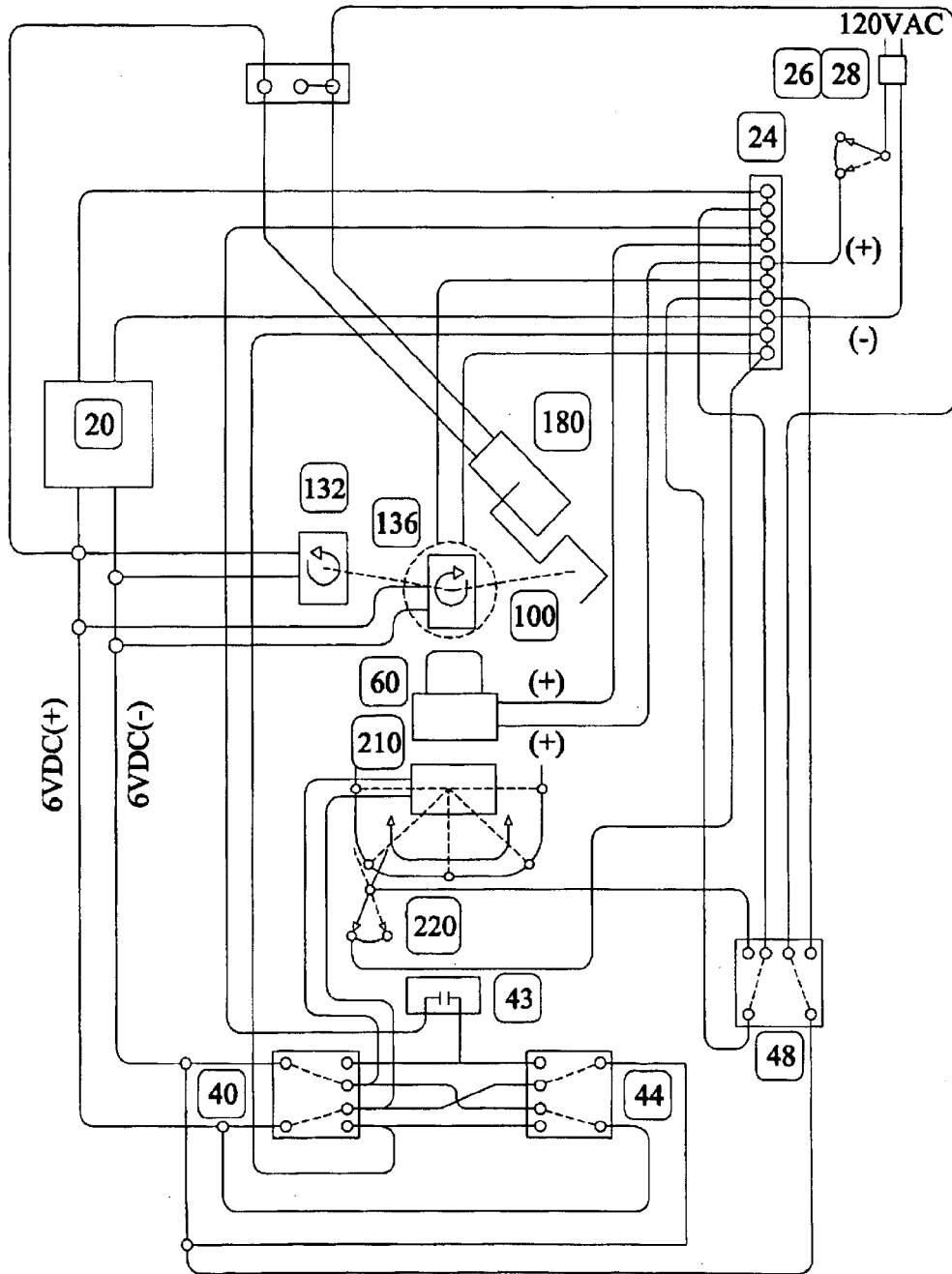

Fig.16A

FLOW DIAGRAM OF OPERATIONAL STEPS

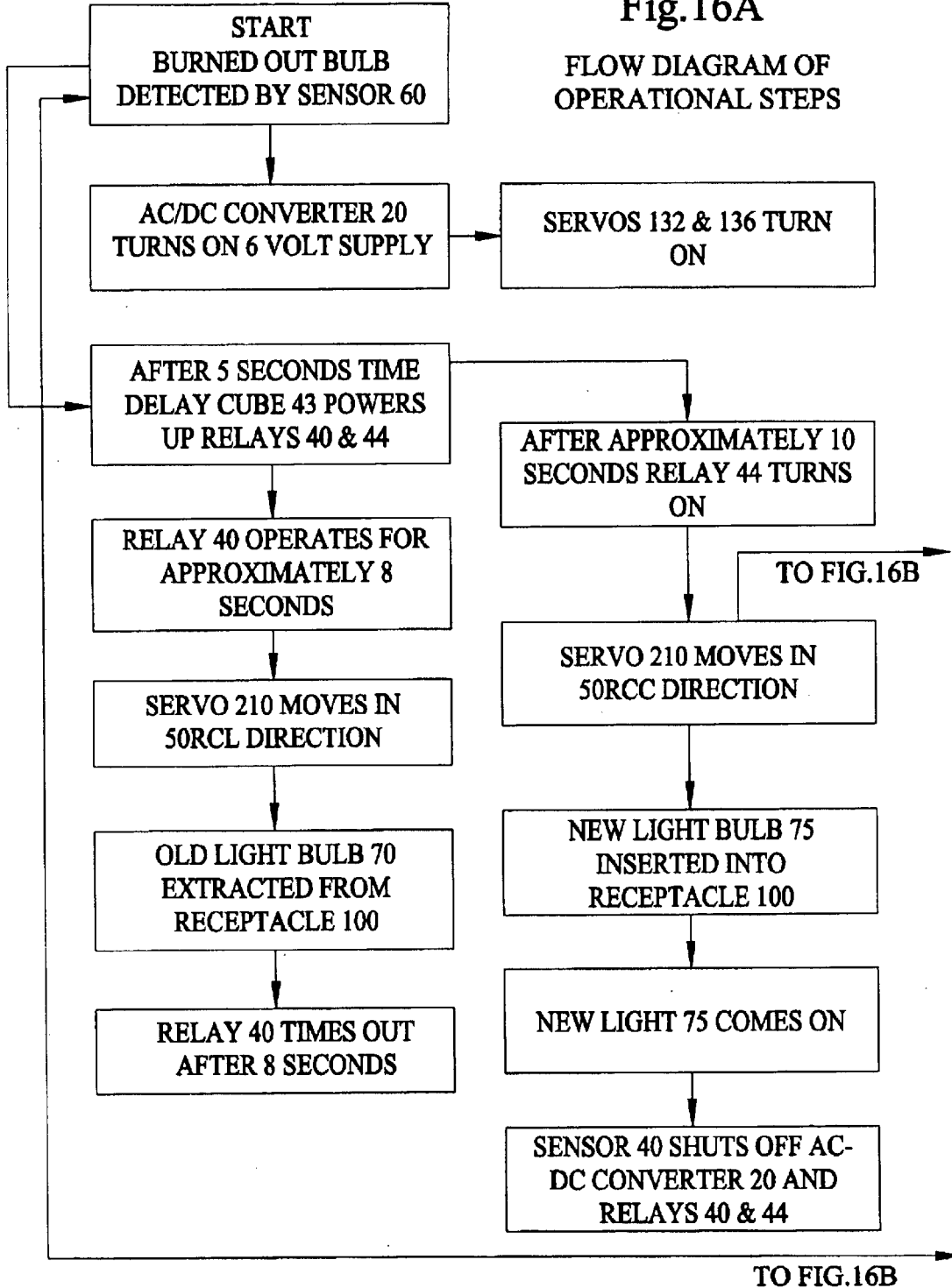

Fig.16B

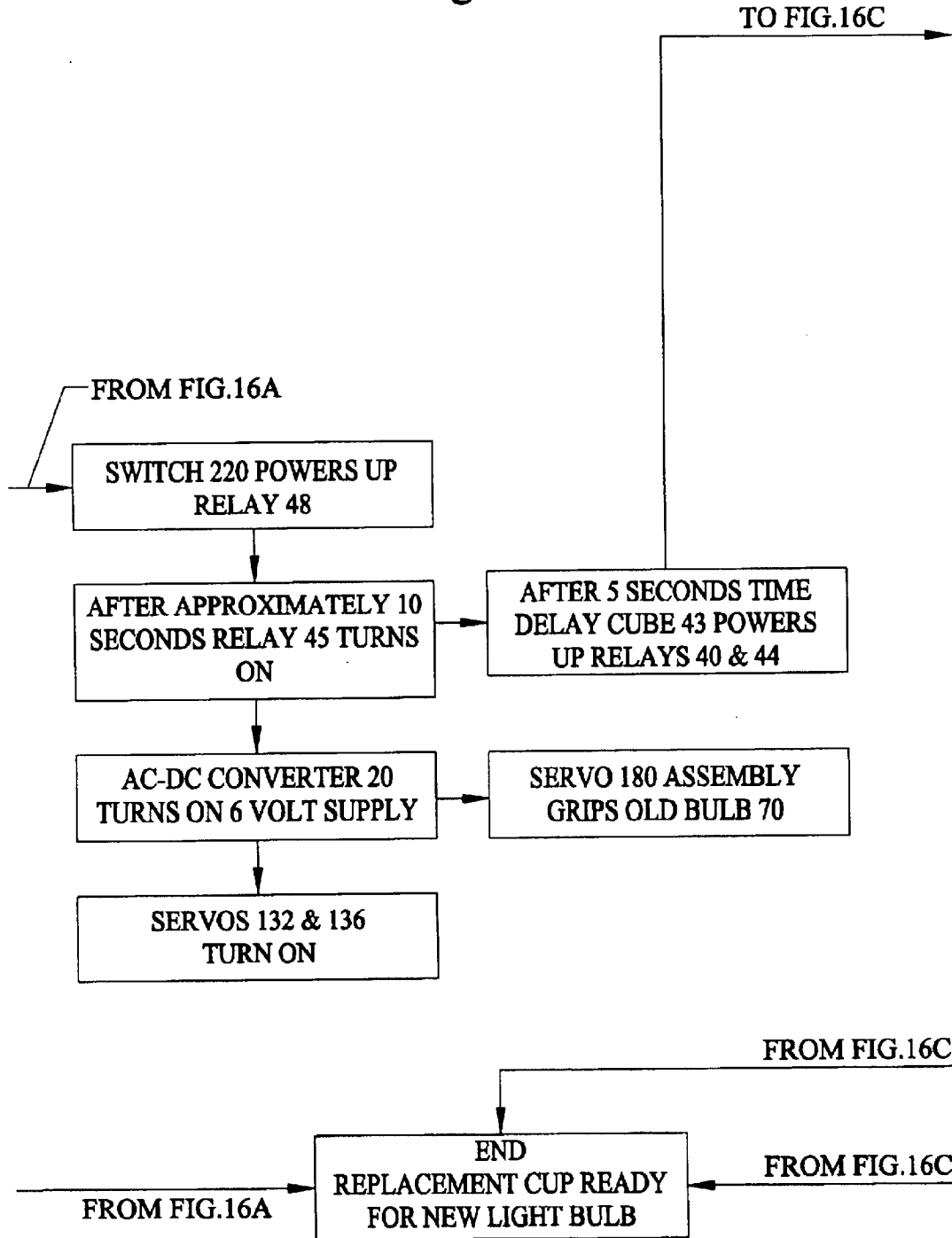

Fig.16C

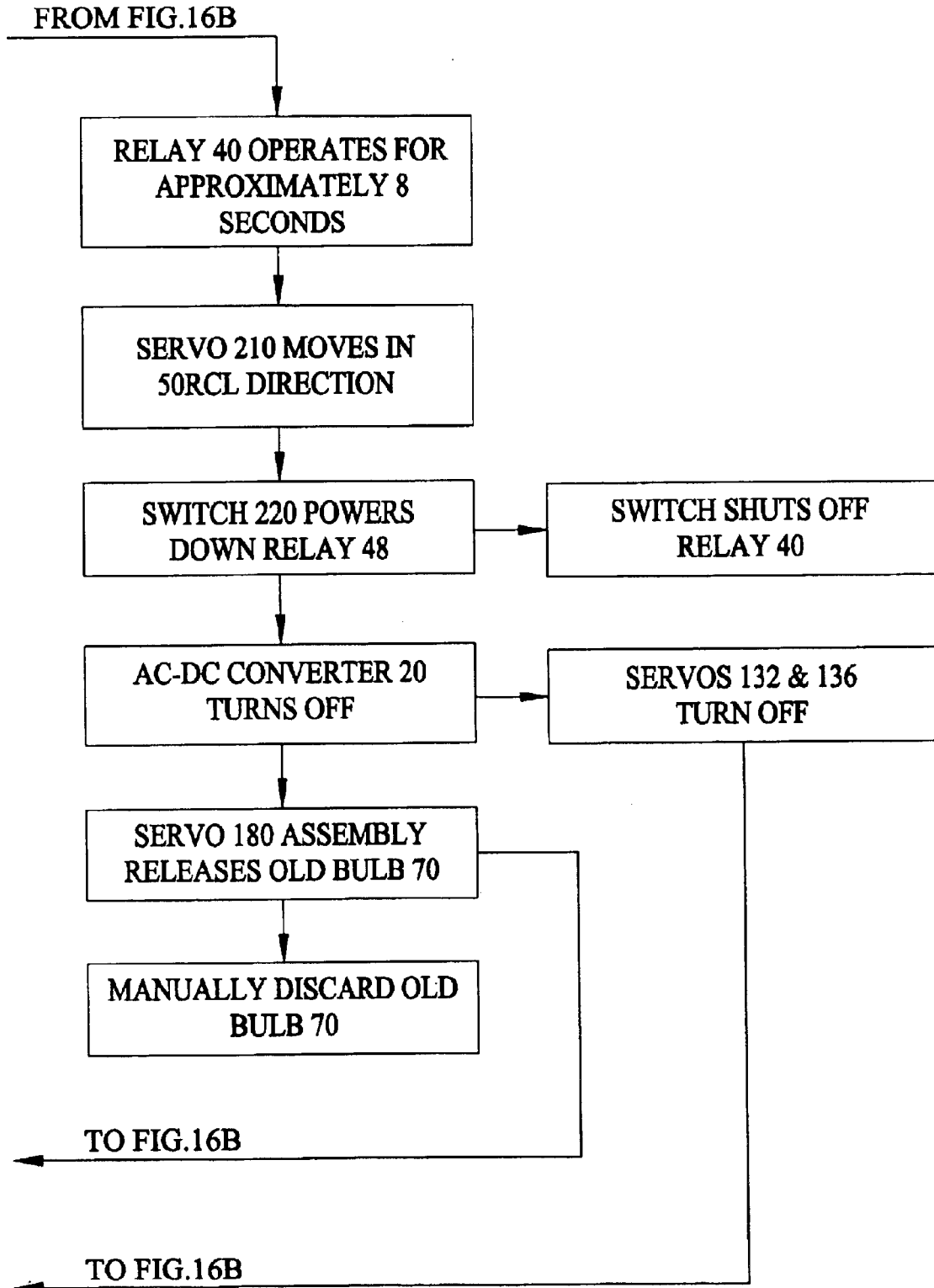
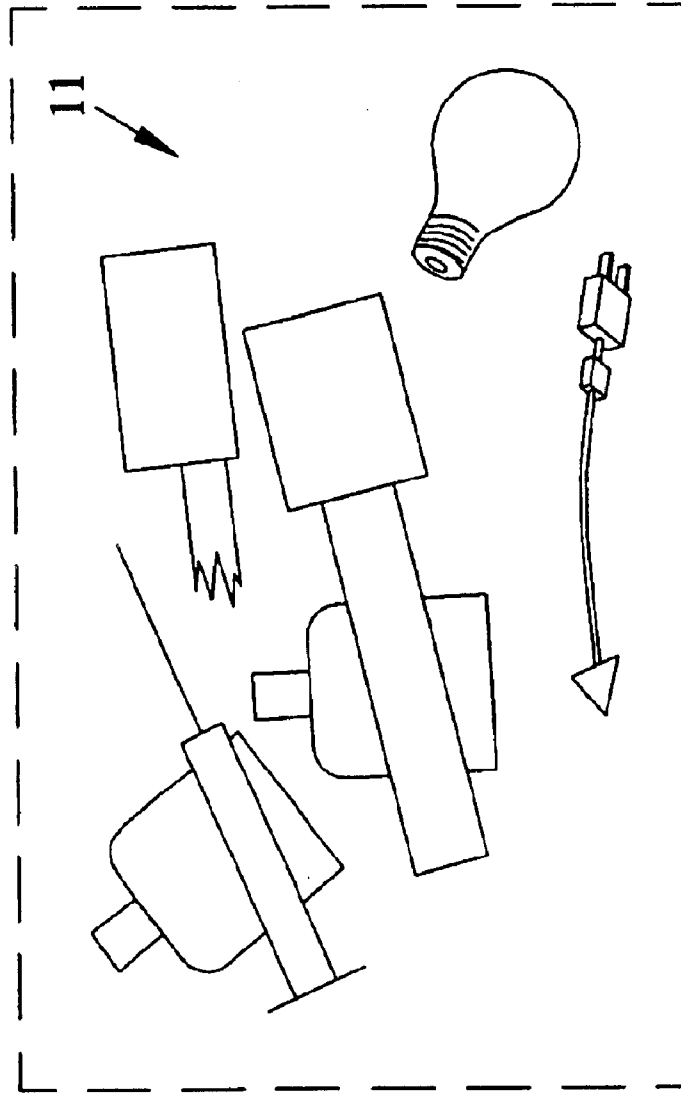

Fig.17

1000



11

1

LIGHT BULB CHANGER**BACKGROUND AND PRIOR ART**

Current light fixtures, such as table lamps, and the like, generally require various types of 30, 55 and 60 watt type bulbs to be used. When a bulb burns out from use, the general procedure is to physically rotate the bulb and then remove the burned out bulb from the fixture socket. Often times, a burned out bulb will not be immediately replaced, which often results in the light fixture being unusable over that down time. Furthermore, many consumers will not have a spare bulb ready, so that further down time occurs waiting for the consumer to purchase a replacement bulb. These problems with changing out burned out bulbs are further compounded in other types of hard to reach and/or commercial type lights, such as those found on ceilings, light poles, and the like.

Current solutions to burned out bulb problems have generally centered on replacement bulbs having extended lifetimes of use over existing bulbs. However, these extended life bulbs are generally many times more expensive than existing bulbs, and these bulbs still have to be manually mounted and replaced.

Various patents have been proposed over the years for changing light type bulbs. See for example, U.S. Pat. No. 5,558,573 to Smith; U.S. Pat. No. 898,696 to Southworth; U.S. Pat. No. 1,847,953 to Finesy; U.S. Pat. No. 2,637,587 to Robinson; U.S. Pat. No. 4,314,723 to Vermillion; U.S. Pat. No. 4,901,606 to Christensen; U.S. Pat. No. 5,218,889 to Brockberg; and Des. 297,499 to Whitney. However, all of these devices generally require the user physically place a portion of the device such as a suction cup or spring type housing over a bulb, and then physically rotate the device. Some of the patents allow for extension type rods, and the like, to be used for ceiling and pole mounted bulbs. Christensen '889 puts motors into their device to aid in the replacement, but still requires the user to determine when a bulb becomes burned out, and also requires the user to physically handle and manipulate the device into position to be used, as well as physically remove the device after it is used.

Thus, the need exists for solutions to the above problems with the prior art.

SUMMARY OF THE INVENTION

The first objective of the present invention is to provide a light bulb changer method and apparatus that immediately and automatically detects a burned out light bulb condition.

The second objective of the present invention is to provide a light bulb changer method and apparatus that automatically changes out a burned out light bulb for a replacement light bulb.

The third objective of the present invention is to provide a light bulb changer method and apparatus that eliminates having to physically contact the light bulb being changed and replaced.

The fourth objective of this invention is to provide a light bulb changer method and apparatus that eliminates having to search out a replacement bulb when a burned out bulb occurs.

The fifth objective of the present invention is to provide a method that eliminates the downtime of a light fixture between discovering a burned out bulb condition and the time it takes to replace the burned out bulb.

2

Further objects and advantages of this invention will be apparent from the following detailed description of a presently preferred embodiments which is illustrated schematically in the accompanying drawings.

BRIEF DESCRIPTION OF THE FIGURES

FIG. 1 is a perspective view of a first preferred embodiment of the light bulb changer.

FIG. 2 is a front view of the light bulb changer of FIG. 1.

FIG. 3 is a left side view of the light bulb changer of FIG. 2 along arrow 3X.

FIG. 4 is a rear view of the light bulb changer of FIG. 3 along arrow 4X.

FIG. 5 is a right side view of the light bulb changer of FIG. 2 along arrow 5X.

FIG. 6 is a top view of the light bulb changer of the preceding Figures.

FIG. 7A is a front perspective view of the light bulb changer ready to accept a replacement bulb prior to operation.

FIG. 7B is a rear perspective view of the light bulb changer of FIG. 7A.

FIG. 8 is a rear perspective view of the light bulb changer of FIG. 7B with replacement bulb.

FIG. 9A is a front perspective view of the preceding figures with cam follower arm moving to cause removal of the burned out bulb following detection of the burned out bulb condition.

FIG. 9B is a rear perspective view of FIG. 9A.

FIG. 10A is a front perspective view of the changer removing the burned out bulb.

FIG. 10B is a rear perspective view of FIG. 10A.

FIG. 11A is a front perspective view of the changer moving the replacement bulb under the empty light socket.

FIG. 11B is a rear perspective view of FIG. 11A.

FIG. 12A is a front perspective view of the changer inserting the replacement bulb in the socket, and also gripping the burned out bulb.

FIG. 12B is a rear perspective view of FIG. 12A.

FIG. 13A is a front perspective view of the transport arm of the changer separating from the replacement bulb, while the changer releases the burned out bulb.

FIG. 13B is a rear perspective view of FIG. 13A.

FIG. 14A is a front perspective view of the changer moved back to the FIG. 7A position.

FIG. 14B is a rear perspective view of FIG. 14A.

FIG. 15 is a block diagram of the electrical circuit that can be used in the preferred embodiment.

FIG. 16 is a flow diagram of the operational steps of the novel invention.

FIG. 17 shows a box version holding a kit form of the novel invention.

DESCRIPTION OF THE PREFERRED EMBODIMENTS

Before explaining the disclosed embodiments of the present invention in detail it is to be understood that the invention is not limited in its application to the details of the particular arrangements shown since the invention is capable of other embodiments. Also, the terminology used herein is for the purpose of description and not of limitation.

FIG. 1 is a perspective view of a first preferred embodiment of the light bulb changer 1. FIG. 2 is a front view of

the light bulb changer 1 of FIG. 1. FIG. 3 is a left side view of the light bulb changer 1 of FIG. 2 along arrow 3X. FIG. 4 is a rear view of the light bulb changer 1 of FIG. 3 along arrow 4X. FIG. 5 is a right side view of the light bulb changer 1 of FIG. 2 along arrow 5X. FIG. 6 is a top view of the light bulb changer 1 of the preceding Figures.

A list of the components for the figures will now be defined.

1 Light Bulb Changer
 10 Platform Base
 12 Rubber Feet
 20 Power Supply Transformer
 22 power line
 24 terminal
 26 power line
 27 power switch
 28 wall plug
 30 terminal on transformer 20
 32 wire line connector
 34 terminal under first relay control 40
 36 terminal under second relay control 44
 38 terminal under third relay control 48
 40 First Relay Control
 41 Rotatable Knob on First Relay Control 40
 42 line connector between controls 40, 44
 43 solid state cube relay
 44 Second Relay Control
 45 Rotatable Knob on Second Relay Control 44
 46 line connector between controls 44, 48
 48 Third Relay Control
 49 Rotatable Knob on Third Relay Control
 50 Cam follower transfer arm
 51 Outer end of arm 50
 52 Longitudinal slot along outer end 51 of arm 50
 54 Inner end of arm 50
 55 Rotatable axle pin for arm 50
 50R Double arrow showing rotating directions of arm 50
 60 Optical sensor determines burnout condition
 70 Light bulb in lit condition monitored by optical sensor 60
 72 Threaded stem of bulb 70
 75 Replacement bulb
 77 Threaded stem of replacement bulb
 90 light boom for connecting socket 100 to post 80
 92 outer swivel end of boom
 94 inner end of boom attached to post 80
 100 light socket for bulb 70
 210 Servo Motor for Rotating pin 55
 212 C-shaped Bracket connects motor 210 to cam groove plate 140
 140 Cam groove plate
 142 U-shaped slot in groove plate 140
 141 Upper left slot stop end
 143 Upper right slot stop end
 150 Cam follower bar
 152 Outer end of bar 150
 158 Inner end of bar 150
 110 Articulating transport arm assembly
 112 Inner end of arm assembly about post 80
 112R double arrow horizontal rotating horizontal plane direction of arm assembly 110 about post 80
 114 pivot end of double arms 116 of assembly 110
 114R Double arrow vertical pivoting rotation plane direction of arm assembly 110
 116 Double arms on arm assembly 110
 118 Outer end of arms 116
 120 Bulb gripping cup assembly 120
 121/125 platforms for bulb cup holders 122, 126

122/126 Bulb cup holders
 123/127 Mouths of cup holders 122/126
 124/128 inwardly Sloping side walls of cup holders 122/126
 132/136 Servo motors for bulb cup holders 122/126
 80 Main Support Rod Post
 82 lower mounted end of Support Rod post
 84 nut/washer for stopping upward movement of rotatable assembly end 112 about post 80
 86 nut/washer attached to upper end of spring 200
 88 upper end of post 80
 89 fasteners(nuts/washers on upper end 88 of post 80
 200 Stabilizing spring for articulating arm assembly
 202 upper end of spring 200
 204 lower end of spring 200
 160 Bulb Stem grip assembly
 162 arm portion of grip assembly 160
 163 inner end of arm 162
 164 portion of arm 162 where finger 172 pivots
 166 outer fixed bulb stem grip finger with L-shape
 168 inwardly facing tip end of L-shaped grip finger
 170 moveable bulb stem grip finger
 172 L-shaped portion of finger 170
 173 pivotal end connection of finger 170
 175 opposite end of grip finger 170
 176 grip finger link
 177 pivot correction link 176
 178 rotatable cam
 178R rotatable direction of cam 178
 190 grip finger return spring
 192 spring end attached to grip finger portion 172
 194 spring end attached to flange plate 196
 196 flange plate attached to base portion 163 of grip assembly arm 162
 180 servo motor controlling cam 178
 220 Cam follower locator switch
 300 see-through shield/dome
 400 lamp shade attachment
 500 demonstration operation switch/coin operation switch/money operation switch
 A detailed description of the components in relation to the Figures will now be described. Referring to FIGS. 1-6, light bulb changer 1 can include a base 10, such as a platform with lower extending feet portions 12, such as rubber footers, and the like, for supporting the platform base 10, on a surface such as a table, desk, and the like. On platform base 10, can be a power supply transformer 20 which connects the changer 1 to a wall plug 28 power source such as a 120 volt power supply by way of wires 26, terminal 24, and power line 22. A terminal 30 connects transformer 20 by wire line connector 32 to a terminal 34 under First Relay Control 40, such as a solid state time delay relay manufactured by Dayton, which can be adjusted to operate at a delay time of approximately 0.1 to 10 seconds, by selecting a setting with rotatable control knob 41. Line 42 connects First Relay Control 40 to terminal 36 under Second Relay Control 44, such as a solid state time delay relay manufactured by Dayton, which can be adjusted to operate at a delay time of approximately 1 second to approximately 60 seconds, by selecting a setting with rotatable control knob 45. Line 46(FIG. 5) connects Second Relay Control 44 to terminal 38 under Third Relay Control 48, such as another solid state time delay relay manufactured by Dayton, which can be adjusted to operate at a delay time of approximately 1 to approximately 180 seconds by selecting a setting with rotatable control knob 49.

Referring to FIGS. 1-6, a rectangular plate 140 can be perpendicularly and fixably mounted to an upper surface of

5

base platform **10**. Plate **140**, also called a cam groove plate, can have a U-shaped slot **142** having an upper left slot stop end **141** and an upper right slot stop end **143** therein. Attached to the top of plate **140** can be a downwardly facing C-shaped bracket **212** which supports a servo type motor **210** thereon. Servo motor **210**, can rotate pin **55** that is connected to inner end **54** of cam follower arm **50** in the direction of double arrows **50R**. A longitudinal slot **52** is through arm **50** running within outer arm end **54**.

Fixably mounted to base platform **10** can be the lower end **82** of a main threaded support rod post **80**. An articulating double arm assembly **110** has an inner end **112** which can rotate in a horizontal plane in the direction of double arrows **112R** about support rod post **80**, and is held in place by rotatably abutting against fixed nut/washer **84** which is threadably attached about a lower third portion of rod post **80**. Adjacent inner end **112**, can be pivoting arm ends **114** of arms **116**, which pivotably rotate up and down in a vertical plane in the direction of double arrows **114R**.

A cam follower bar **150** has an inner end **152** fixably mounted to outer end portion **118** of articulating arm assembly **110**.

Servo motor **210** rotates cam arm **50** in the direction of double arrows **50R**, which allows for outer end **158** of cam follower bar **150** to slide between upper left slot end **141** to upper right slot stop end **43** within U-shaped slot **142** that is in groove plate **140**.

Moving the cam follower arm **150** then moves articulating arm assembly in the direction of double arrows **112R** in the horizontal plane about rod post **80** while pivotably rotating the double arms **116** up and down in the direction of arrows **114R** in the vertical plane about end **112** of the arm assembly **110** which is adjacent to rod post **80**.

Referring to FIGS. **1**, **3**, **4** and **6**, a cam follower switch **220** can be attached to the back of cam groove plate **140** adjacent to a lower left horizontal portion of U-shaped slot **142**. Switch **220** includes an upwardly protruding stem portion **222**, which is springably pivotally fixed in an upwardly protruding perpendicular direction from a fixed base portion **226**. As the cam follower bar slides through and travels through the U-shaped slot **142**, the horizontally oriented bar **50** moves the moveable stem portion **222** of switch **220** in the direction of double arrows **220R**.

Referring to FIGS. **1** and **3**, stabilizer spring **200** for arm assembly **110** has an upper end **202** fixably attached to an upper mid-portion **86**, such as a nut/washer threadably attached to rod support post **80** and a lower end **204** attached to a mid-portion along double arms **114**.

Referring to FIGS. **1**, **3-6**, a light sensor **60**, such as but not limited to an optical sensor, U.L. photoelectric switch rated for 120 VAC, model #870J, can be mounted to the upper portion of the C-shaped bracket **212**, and is continuously aimed at the existing lit light bulb **70**, in order to determine, whether the light bulb **70** is burned out, or not. Alternatively, an electrical type switch can be used instead of the optical sensor **60**, which can be wired to the bulb **70** power supply, which would also indicate when a burned out condition exists.

Referring to FIGS. **1-6**, the monitored light bulb **70** can include a standard light bulb, such as but not limited to a Sylvania 40 W soft light bulb, having a threaded stem **72** that screws into a socket **100**, which in turn is suspended in a downward perpendicular direction from a swivel connector **92** on one end of a horizontal light boom **90**. An opposite end **94** of the horizontal boom **90** can be fixably attached to an upper end **88** of the rod post **80** by fasteners **89** such as nuts/washers.

6

Attached to both sides of the outer end portion **118** of articulating arm assembly **110**, can be bulb gripping cup assembly **120**, having two platforms **121**, **125** for each supporting bulb cup holders **122**, **126** thereon. Each of the cup holders can be formed from thin walled flexible plastic type cups having open mouth portions **123**, **127**, with inwardly sloping side walls **124**, **128**, respectively. Attached to the underside of platforms **121**, **125**, can be respective Servo motors **132/136** for bulb cup holders **122/126**.

Referring to FIGS. **1-3**, **5** and **6**, bulb stem grip assembly **160** includes an arm portion **162** having an inner end **163** attached to an upper end **88** of rod post **80** by fasteners **89**, and an opposite fixed bulb stem grip finger **166** having an L-shape, with inwardly facing tip end **168**. A moveable bulb stem grip finger **170** can include a L-shaped portion **172** having one end **173** pivotally connected by a pin, and the like, to a portion **164** of arm portion **162** of the bulb stem grip assembly **160** where L portion pivots. The opposite end **175** of moveable grip finger **170** is pivotally attached to a moveable grip finger link **176**, which in turn is pivotally connected at an opposite end **177** to a rotatable cam **178**, such that rotating the cam **178** in the direction of double arrows **178R**, moves the finger link **176** such that moveable grip finger **172** pivotally moves in the direction of double arrows **170R**, respectively. A grip finger return spring **190** has one end **192** attached to the outer end of moveable grip finger **172**, and an opposite end **194** attached to a flange plate **196**, that is attached to the base portion **163** of gripping assembly arm **162**. The grip finger return spring **190** is biased to keep the moveable finger **172** in an open position. A servo motor **180** attached underneath plate **196** operates the rotatable cam **178** to open and close the moveable finger **172**.

An operating description of the novel changer embodiment will now be described in reference to FIGS. **7A-14B**. Initial Rest Position

FIG. **7A** is a front perspective view of the light bulb changer **1** ready to accept a replacement bulb in cup holder **122** prior to operation. FIG. **7B** is a rear perspective view of the light bulb changer **1** of FIG. **7A**. The changer **1**, can have an existing bulb **701** light socket **100**, where the bulb **70** can be powered on by a wall plug **28**, and/or a toggle type switch **27**, and the like.

FIG. **8** is a rear perspective view of the light bulb changer **1** of FIG. **7B** with replacement bulb **75** with threaded stem portion facing upward positioned in replacement bulb cup holder **122**. At this point the changer **1** is ready for operation, and the existing bulb **70** can be turned on to.

Burned Out Bulb Condition & Extraction

The components of the changer **1**, stays in the position shown in FIGS. **7A**, **7B** and **8**, until a burned out bulb condition in bulb **70** is detected by optical type sensor **60**.

FIG. **9A** is a front perspective view of the preceding figures with cam follower arm moving to cause removal of the burned out bulb following detection of the burned out bulb condition. FIG. **9B** is a rear perspective view of FIG. **9A**.

Referring to FIGS. **8**, **9A** and **9B**, the burned out bulb condition in bulb **70** can be immediately detected by sensor **60**, which turns on transformer **20**, which operates 6 volt bulb cup servo motors **132**, **136**, grip finger servo motor **180**, and cam follower transfer arm servo motor **210**. Detection of burned out condition by sensor **60** also turns first relay control **40**, to operate the cam follower transfer arm **50** to rotate clockwise (see arrow **50R**) which moves cam follower bar **150**, and move articulating transport arm assembly **110** to move upward (see arrow **114R**) so that cup holder **126** to

securely and tightly wrap about burned out bulb 70 so that the changer 1 is in an extraction position (FIGS. 9A-9B). Simultaneously, as the transport arm assembly 110 is being raised, cup holder 126 is being rotated counter-clockwise in the direction of arrow E, for an extraction, and cup holder 122 is being continuously rotated in clockwise in the direction of arrow S (FIG. 9A). First relay control 40 can be adjusted by knob 41 to a selected time position such as approximately 8 seconds. The changer 1, allows for the cup holder 126 to continue to unscrew burned out bulb 70, and then time out by the setting in first relay control 40.

Removing Burned Out Bulb

FIG. 10A is a front perspective view of the changer 1 removing the burned out bulb 70. FIG. 10B is a rear perspective view of FIG. 10A. After first relay control 40 times out, the second relay control 44 turns on sending a reverse polarity DC current to cam follower transfer arm servo motor 210 to rotate cam follower transfer arm 50 counter clockwise in the direction of arrow 50RCC, which moves the transport arm assembly 110 downward in the direction of arrow 114RD so that unscrewed bulb 70 is separated and is removed from socket 100.

Moving Replacement Bulb Under Socket

FIG. 11A is a front perspective view of the changer 1 moving the replacement bulb 75 under the now empty light socket 100. FIG. 11B is a rear perspective view of FIG. 11A. After burned out bulb 70 is detected, relay 44 can turn on for approximately 10 seconds. Second relay control 44, which can be adjusted by knob 45, to run for a selected time period when activated, such as for approximately 10 seconds, continues to cause cam follower transfer arm 50 to rotate in the direction of arrow 50RCC2, causing the cam follower bar 150 to pass through the lower portion of the U-shaped slot 142, and moving toggle stem 222 of switch 220 in the direction of arrow L1, which then activates the third relay control 48 which can be adjusted to be activated in approximately 10 seconds. As transfer arm 50 is rotating in the direction of arrow 50RCC2, the cam follower bar 150 moves the articulating arm assembly 110 in the direction of arrow 112RC respective to rod post 80 so that the threaded stem 77 of the replacement bulb 75 is positioned under socket 100. Replacement Bulb Positioning, and Burned Out Bulb Removal

FIG. 12A is a front perspective view of the changer 1 inserting the replacement bulb 75 in the socket 100, and also gripping the burned out bulb 70 by the bulb grip finger assembly 160. FIG. 12B is a rear perspective view of FIG. 12A. After a selected delay time, for example approximately 5 seconds, the second relay control 44 then turns on and replacement bulb 75 gets threaded in place inside socket 100 by cup holder 122 moving upward in the direction of arrow 114RS by cam follower bar 150 being moved by cam transfer arm 50, while simultaneously rotating in a clockwise direction as shown by arrow S. The second relay control 44 can be set by knob 45 to a selected time period, such as but not limited to approximately 15 seconds, after which the second relay control 44 times out. After being activated, third relay control 48 operates servo motor 180 causing moveable grip finger 172 to close in the direction of arrow G1 about threaded stem 72 of burned out bulb 70. Replacement Finished, Burned Out Bulb Discarded

FIG. 13A is a front perspective view of the transport arm assembly 110 of the changer 1 separating from the replacement bulb 75, while the changer 1 releases the burned out bulb 70. FIG. 13B is a rear perspective view of FIG. 13A. After a set time, the cam arm 50 starts to rotate clockwise in the direction of arrow 50RCL dropping articulating transfer

arm assembly 110 downward in the direction of arrow 114RF lowering cup holder 122 from the replacement bulb 75 that is now screwed onto socket 100. After cam follower arm 150 pushes toggle stem 222 of switch 220 in an opposite direction, the moveable gripping finger 172 opens in the direction of arrow G2 releasing the threaded stem 72 of burned out bulb 70 to drop downward in the direction of arrow DIS to be discarded to a receptacle 79, for disposal, and/or recycling at a later time.

FIG. 14A is a front perspective view of the changer moved back to the FIG. 7A position. FIG. 14B is a rear perspective view of FIG. 14A. The changer 1, can now accept another replacement bulb in cup holder 122, and then be turned on, where the changer can repeat the novel steps and operation described above after another burned out bulb condition is detected by sensor 60.

Novelty Embodiment

Referring to FIGS. 14A-14B, the invention can be used for novelty effects where the device is protected under a see-through cover or shield 300, on countertops, tables in residential type homes, or commercial establishments such as bars, restaurants, and the like. A demonstration switch 500 such as a push button switch, and the like, can be used to momentarily turn on a burned out condition in bulb 70 so that users can visualize the mechanical operation of the changer 1. Alternatively, switch 500 can include a coin/money operated slot, and the like, so that the changer 1 can be used in public entertainment type applications, such as those found in restaurants, and the like, for novelty and entertainment applications of the changer 1.

Useful Light Source Embodiment

Referring to FIG. 14B, the invention can also be used as a useful light source, by using a removable shade 400, and the like to cover the components, as needed.

FIG. 15 is a block diagram of the electrical circuit that can be used in the preferred embodiment. A list of the components that can be used in the circuit will now be described. Component 20 refers to a 120VAC to 6 VDC converters such as a 1000 milliamp Radio Shack AC to DC Converter part # 273-1762. Part 60 refers to a UL listed photo electric switch rated for 120 VAC, such as ACE hardware part # 870J. Part 40 refers to a time delay relay interval type with range 0.1 to 10 seconds with a contact rating of 10 amps at 120 VAC, such as Dayton part #6X603N with matching octal socket. Component 43 refers to a solid state relay time on delay type with timing range 0.25 to 5 seconds, having input and output contact ratings of 1 amp at 120VAC, such as Dayton part #2A560 with standard press on electrical connectors. Component 44 refers to a time delay relay on delay type with timing range 1-60 seconds with contact ratings of 10 amps at 120VAC such as Dayton part # 5YZ85M with matching octal socket. Component 48 refers to a time delay relay on delay type with timing range 1-180 seconds with contact ratings of 10 amps at 120 VAC, such as Dayton part # 5X829N with matching octal socket. Component 220 refers to Radio Shack single pole double throw toggle switch rated 3 amps at 120VAC with solder end connectors, toggle lever modified with applied small diameter neoprene flex tubing. Components 26/28 refer to a UL listed replacement power supply cord with inline on/off switch, such as ACE Hardware issue # BW2293 cord rated at 10 amps 120VAC. Components 132/136/210 refer to a three-standard remote control Futaba S3003 5V high torque servo motors modified to accommodate direct DC +/- wired directly to interval 5V motor. Component 24 refers to a standard 6 connector terminal block with 3/8 inch dimension between terminal centers, rated for 10 amps 120 VAC. 100

refers to standard UL rated light fixture 150 Watts Par 38, such as those sold under the mark Campax®. The wiring used in the electrical block circuit can be 16 AWG rated wire or higher for all 120 VAC service ratings.

FIG. 17 shows a box/package 1000 that can contain disassembled components 1' of the novel changer 1, so that the invention can be used in a kit form, and the like.

The invention can be in a kit form, packaged and sold in a disassembled state that includes a light fixture, on which the detecting means, removing means, and replacing means are mounted with the light fixture.

The invention can be useful as an actual light source for use by consumers. The invention can have special applications for consumers with handicaps that are not able to easily replace existing light bulbs in an efficient manner.

The invention can be used as a retrofit for existing light fixtures, where the detecting means, removing means and replacing means can be mounted by a user to an existing light fixture, such as a table lamp, ceiling fixture, and the like.

Although the invention has been described for being used with light sources such as light bulbs, the invention can be used with other types of lights such as but not limited to fluorescent lights, and the like, having different shapes, and the like, from globe shaped to tubular shaped, and the like. Thus, different types and shapes of lights can be used.

While the invention has been described, disclosed, illustrated and shown in various terms of certain embodiments or modifications which it has presumed in practice, the scope of the invention is not intended to be, nor should it be deemed to be, limited thereby and such other modifications or embodiments as may be suggested by the teachings herein are particularly reserved especially as they fall within the breadth and scope of the claims here appended.

We claim:

1. A light bulb changer apparatus, comprising:
 - means for immediately detecting a burned out condition in a light bulb;
 - means for automatically removing the burned out bulb upon; and
 - means for automatically replacing the burned out bulb with a replacement bulb, wherein the detecting means, removal means, and replacing means occurs automatically in succession without human intervention.
2. The light bulb changer apparatus of claim 1, further comprising:
 - a light fixture.
3. The light bulb changer apparatus of claim 1, wherein the detecting means includes: an optical light sensor.
4. The light bulb changer apparatus of claim 1, wherein the detecting means includes: a power switch.
5. The light bulb changer apparatus of claim 1, wherein the automatic removing means and the automatic replacing means each includes: a cone shaped sleeve for slipping about a portion of the burned out bulb and the replacement bulb.
6. A method of automatically replacing burned out light bulbs, comprising the steps of:
 - instantly detecting a burned out condition in a light bulb supported in a fixture;

automatically removing the burned out bulb from the fixture; and

automatically replacing the burned out bulb in the fixture with a replacement bulb, wherein the steps of detecting, removing, and replacing occurs in automatic succession without human intervention.

7. The method of claim 6, wherein the detecting step includes the step of:

detecting the burned out condition with an optical sensor.

8. The method of claim 6, wherein the detecting step includes the step of:

detecting the burned out condition with a power current sensor.

9. The method of claim 6, wherein the automatically removing and the automatically replacing steps include the steps of:

rotating the burned out bulb from the fixture in one direction; and

rotating the replacement bulb into the fixture in an opposite direction.

10. A method of assembling an automatic changer for an existing light fixture having an existing light source, from a kit, comprising the steps of:

providing a component for detecting a burned out condition from the existing light source, a component for removing the burned out light source and a component for replacing the burned out light source, and an additional light source;

assembling the detecting component, the removing component and the replacing component from the kit into an assembly;

and retrofitting the existing light fixture with the assembly; and

automatically detecting the burned out condition from the existing light source on the existing light fixture by the assembly;

automatically removing the existing light source having the burned out light condition, and

automatically replacing the existing light source having the burned out light condition with the additional light source, wherein the steps of detecting, removing, and replacing occurs in automatic succession without human intervention.

11. The method of claim 10, wherein the detecting step includes the step of:

detecting the burned out condition with an optical sensor.

12. The method of claim 10, wherein the detecting step includes the step of:

detecting the burned out condition with a power current sensor.

13. The method of claim 10, wherein the automatically removing and the automatically replacing steps include the steps of:

rotating the burned out light source from the fixture in one direction; and

rotating the additional light source into the fixture in an opposite direction.