



US006895694B2

(12) **United States Patent**  
Nye

(10) **Patent No.:** US **6,895,694 B2**  
(45) **Date of Patent:** May 24, 2005

(54) **TOE SHOE**

(76) Inventor: **William S. Nye**, 200 First Ave. West,  
Suite 400, Seattle, WA (US) 98119

(\* ) Notice: Subject to any disclaimer, the term of this  
patent is extended or adjusted under 35  
U.S.C. 154(b) by 0 days.

(21) Appl. No.: **10/299,554**

(22) Filed: **Nov. 19, 2002**

(65) **Prior Publication Data**

US 2004/0093761 A1 May 20, 2004

(51) **Int. Cl.<sup>7</sup>** ..... **A43B 5/12**

(52) **U.S. Cl.** ..... **36/8.3; 36/96**

(58) **Field of Search** ..... **36/8.3, 96**

(56) **References Cited**

**U.S. PATENT DOCUMENTS**

1,520,708 A	12/1924	Goldstein et al.	
1,693,174 A	11/1928	Capezio	
RE17,753 E	* 7/1930	Haney	36/8.3
1,889,275 A	11/1932	Domahoski	
1,927,211 A	9/1933	Harris	
2,810,214 A	* 10/1957	Wolfe	36/8.3
3,797,137 A	* 3/1974	Harkness	36/113
4,026,046 A	* 5/1977	Clark et al.	36/113
4,901,453 A	2/1990	Gaynor	

5,035,069 A	7/1991	Minden
5,111,597 A	5/1992	Hansen et al.
5,191,726 A	3/1993	Vallee
5,740,618 A	4/1998	Minden

**FOREIGN PATENT DOCUMENTS**

AU	644733	12/1993
DE	0241010	* 11/1986
GB	321825	11/1929
GB	403089	12/1933

\* cited by examiner

*Primary Examiner*—Ted Kavanaugh

(74) *Attorney, Agent, or Firm*—Miller Nash LLP

(57) **ABSTRACT**

A toe shoe capable of providing support to a ballet dancer's foot while dancing en pointe. The toe shoe preferably includes a toe box in the toe of the toe shoe, an upper, and an outer sole. Support structure within the toe shoe includes a longitudinal support member, a foot encircling tubular sleeve, and/or a toe ridge. In a first preferred embodiment, the support structure includes the longitudinal support member, foot encircling tubular sleeve, and toe ridge. In a second preferred embodiment, the support structure includes the longitudinal support member and foot encircling tubular sleeve. In a third preferred embodiment, the support structure is the longitudinal support member and toe ridge.

**27 Claims, 4 Drawing Sheets**

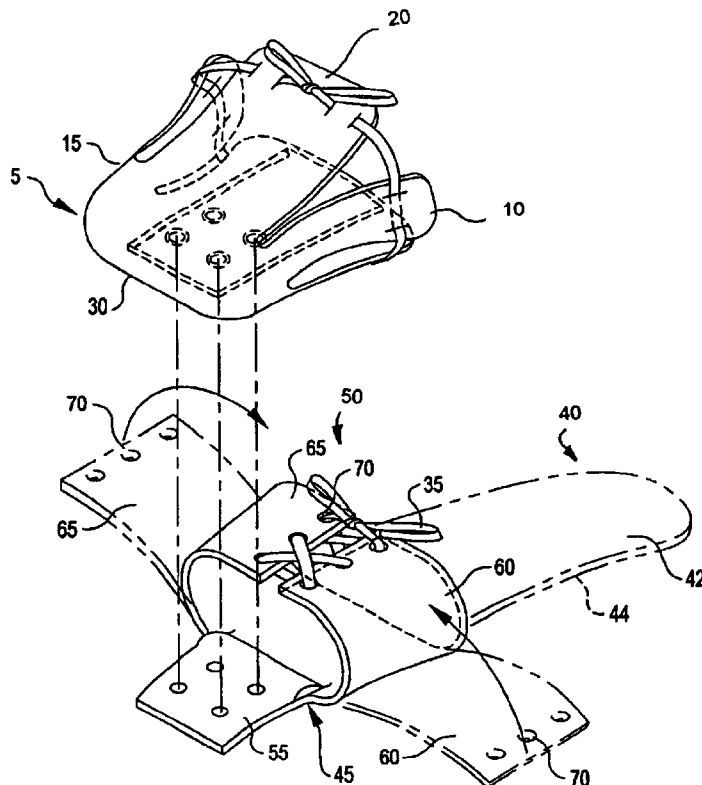

FIG. 1

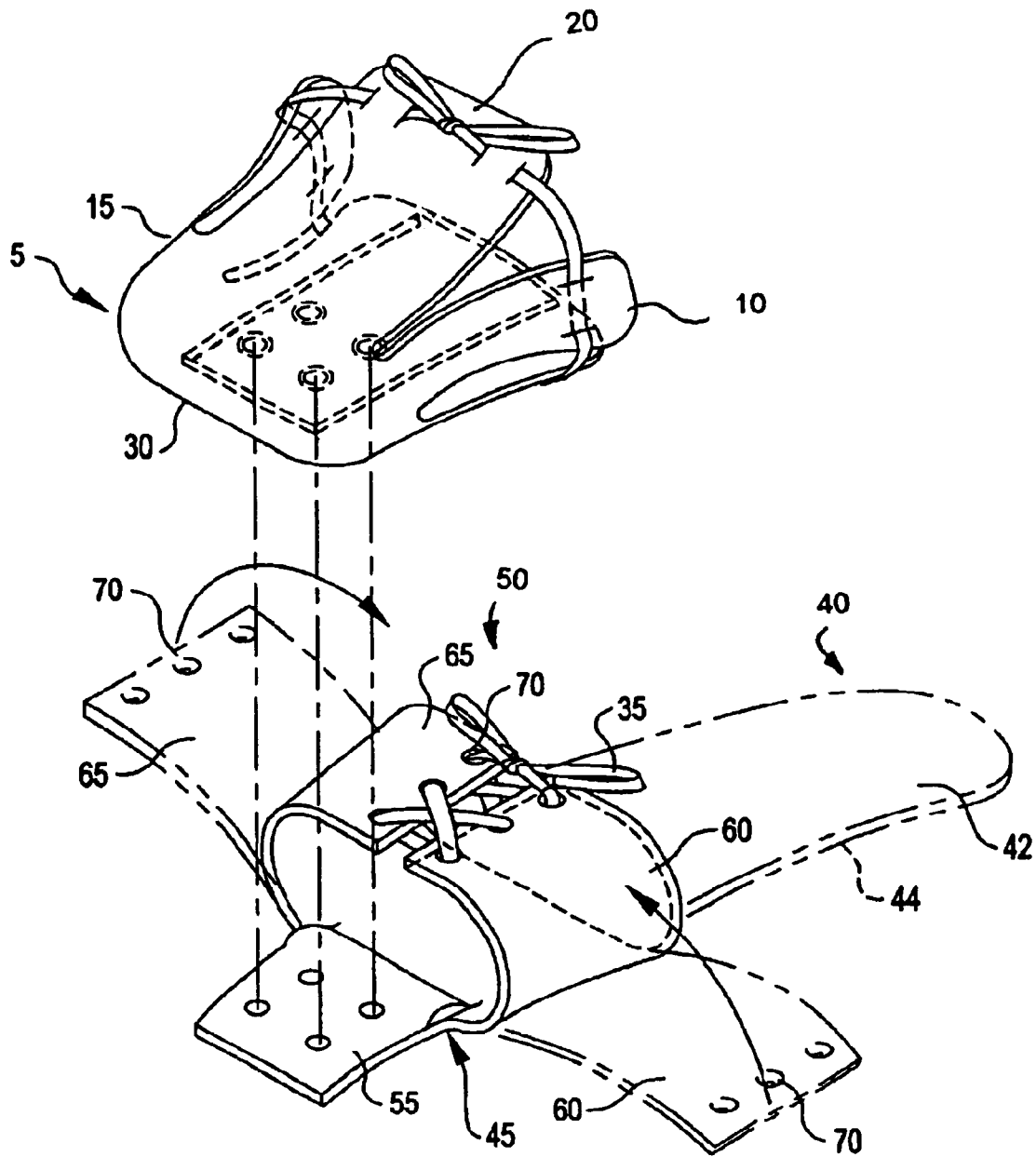

FIG. 2

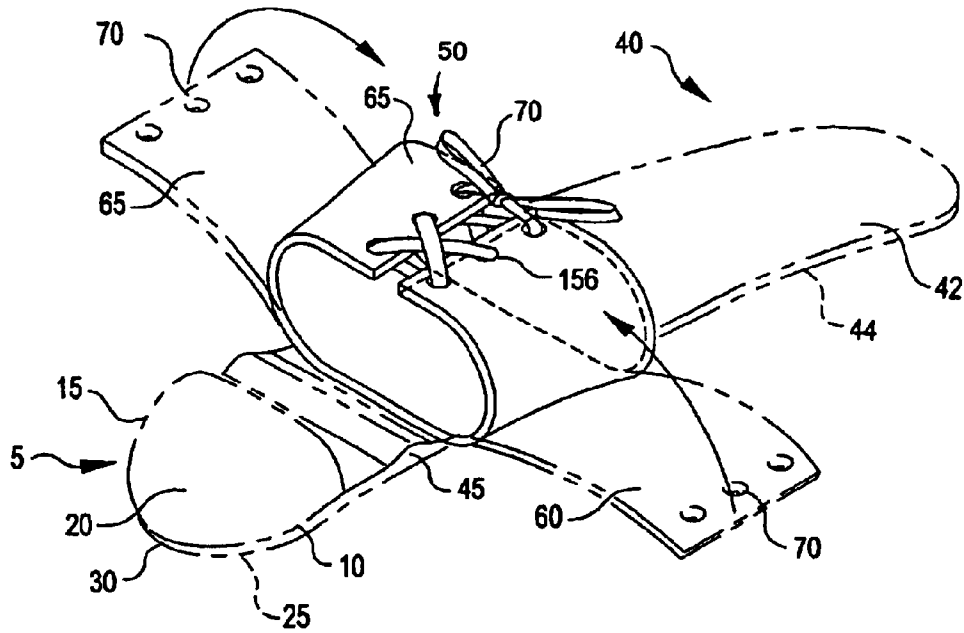

FIG. 3

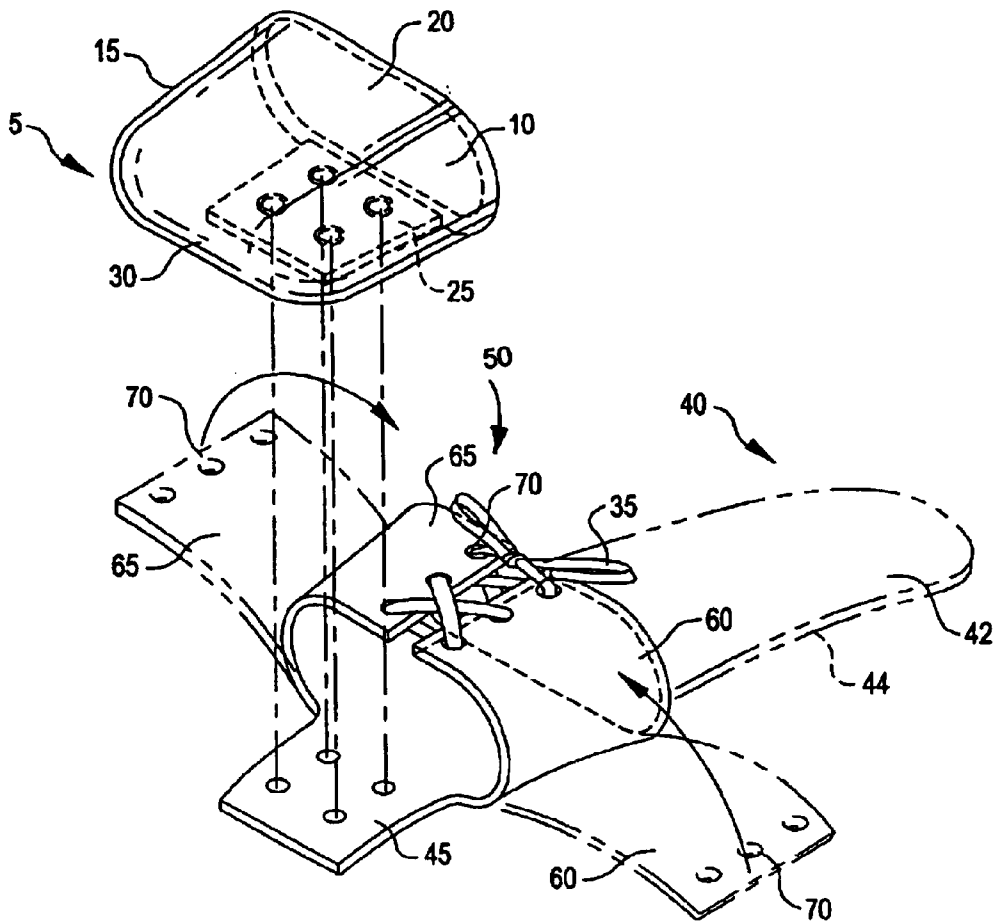

FIG. 4

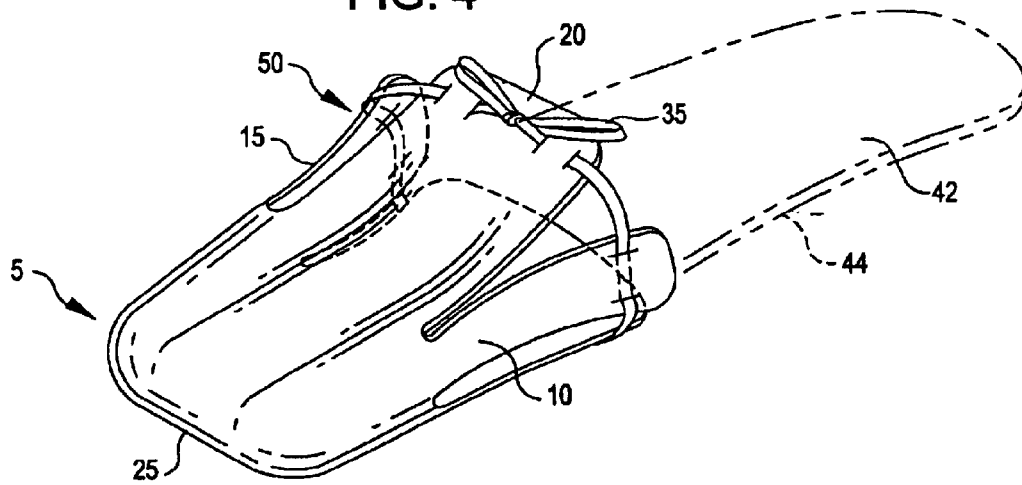

FIG. 5

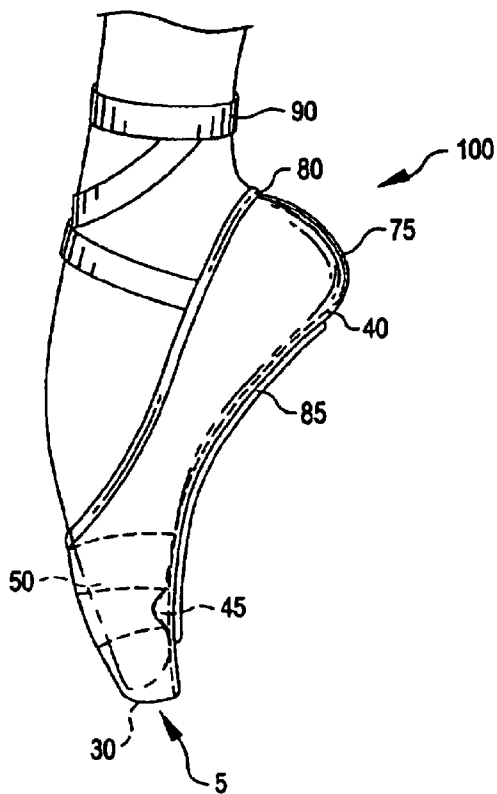

FIG. 6

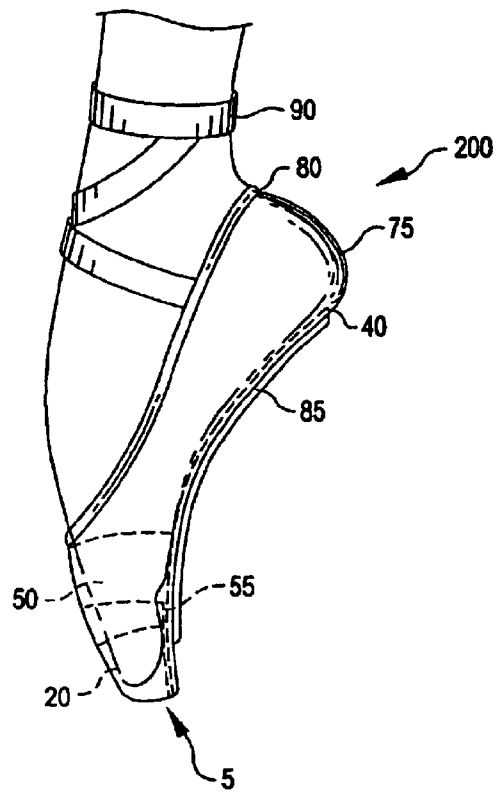
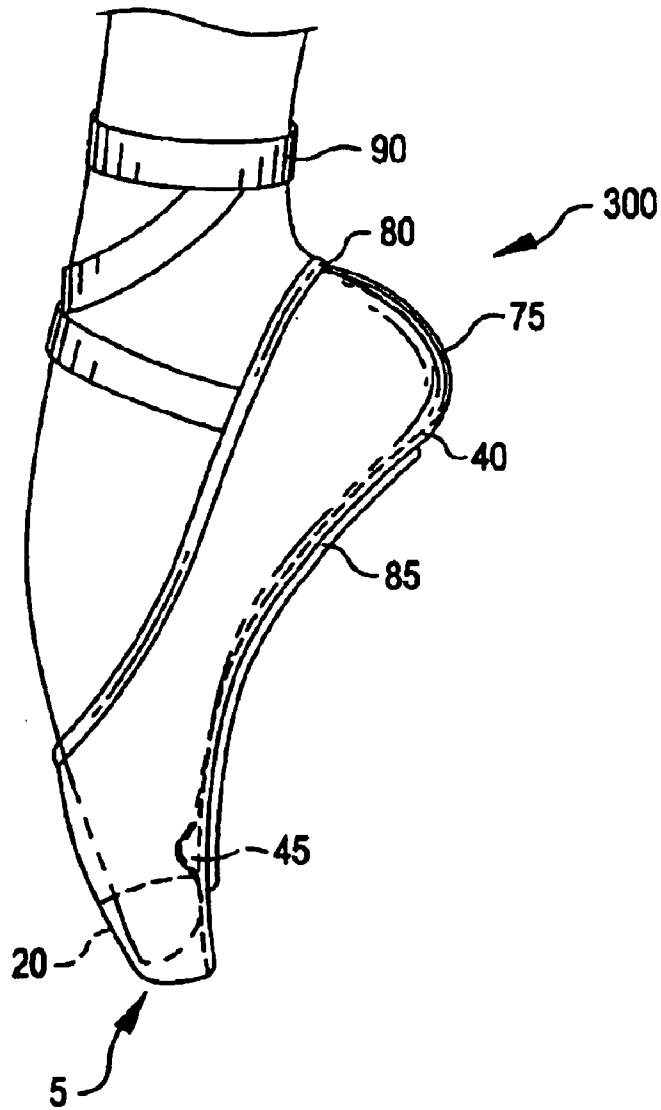

FIG. 7



## BACKGROUND OF INVENTION

## A. Field of Invention

The present invention is directed to a toe shoe, and more specifically, to a toe shoe capable of providing support to a ballet dancer's foot, toes, and ankle during en pointe dancing.

## B. Description of the Related Art

The design and materials of the traditional toe shoe, also known as a "pointe shoe," have remained virtually unchanged for centuries. Generally made by hand, the traditional toe shoe utilizes layers of fabric, burlap, cardboard, paper, plastic, leather, or any combination thereof. The layers of material may be saturated with glue to form a reinforced toe box. A hard insole, called a "shank," and an outer sole are attached to the toe box. Glue, stitching, small nails, or any combinations thereof, hold the toe shoe together. A fabric upper, usually a pink satin material, covers the toe shoe. Satin ribbons or elastic straps are often sewn to the sides of the toe shoe and tied or secured around the ballet dancer's ankle to ensure that the toe shoe remains on the dancer's foot.

Although the traditional toe shoe has been used by many generations of ballet dancers, the traditional toe shoe is known in the art to be uncomfortable, even painful. The toe box compresses the sides of the foot, often exacerbating problems that are associated with the hopping and leaping en pointe required by ballet choreography. Further, traditional toe shoes lack shock absorption, offering no protection to the ballet dancer who must repeatedly jump during the course of a performance or practice.

General principles of physics illustrate how dancing en pointe, when performed in traditional toe shoes, creates forces that act on the body of the ballet dancer. It is believed that these forces contribute to the daily wear and tear on a dancer's body, and specifically, to the dancer's toes, feet, and ankles.

For example, ballet dancing involves movements of the dancer's body interspersed with motionless poses. When a ballet dancer dancing en pointe is positioned in a motionless pose, the sum of all forces and torques acting on the dancer's body is approximately zero. This means that the dancer's center of gravity lies on a vertical line that passes from the dancer's body down to the area of support, which is the dancer's foot, toes, and ankle. This downwardly directed force of gravity is balanced by a force rising upward from the floor on that same vertical line. Therefore, the dancer's foot, toes, and ankle are subject to a force that is at least equal to the dancer's weight. This force may increase as the dancer accelerates from a flat-footed position to an en pointe position while practicing or performing.

Ballet dancing also involves turns en pointe, which are commonly known in the art as pirouettes on the point of a ballet dancer's toe shoes. Pirouettes specifically require turns on the front end of the toe box of the toe shoe. The pirouette begins with a preparatory position. The dancer then rotates her arms, torso, and legs with respect to the floor. The twisting force or torque of the dancer's body is carried into the floor by her foot, which allows her to produce the turning motion of the pirouette as she goes from the sole of her foot to en pointe. The upward torque from the floor against the dancer causes an angular acceleration that produces the turning motion. The dancer's toes, feet, and ankles absorb the brunt of the floor's torque.

In addition to forces acting on the ballet dancer's toes, foot, and ankle, there is upward tension in a dancer's achilles tendon because the dancer must push her toes down into the floor in order to remain en pointe while dancing. This tension in the achilles tendon increases as a dancer accelerates from a flat-footed position to an en pointe position, which requires the dancer to push her toes down and lift her heel up. As a result, the achilles tendon must withstand a tension force two to three times the dancer's body weight. With a traditional toe shoe, this tension force is carried longitudinally through the dancer's arched foot to her ankle and leg.

The forces acting on ballet dancers' toes, feet, and ankles, along with the construction of traditional toe shoes, contribute to a number of dancing-related injuries. These injuries include, but are not limited to bunions, blisters, corns, crooked toes, potential or actual stress fractures, tendinitis, sprains, metatarsal bruises, bruises, toe dislocations, and early onset of arthritis. While some of these injuries are relatively minor and heal quickly, other injuries can end a ballet dancer's career.

There have been many attempts to improve upon the traditional toe shoe. U.S. Pat. No. 5,191,726 to Vallee (the "Vallee reference"); U.S. Pat. No. 5,740,618 to Minden (the "Minden '618 reference"); U.S. Pat. No. 5,035,069 to Minden (the "Minden '069 reference"); and U.S. Pat. No. 4,901,453 to Gaynor (the "Gaynor reference") are exemplary of these attempts and are described to show the current state of the art.

The Vallee reference sets forth a ballet shoe designed specifically for either the left or right foot. The shoe is composed of a sole, a flexible upper that is fixed to the sole, and a vamp that is adapted to surround the front part of the foot. The upper is designed so that points of maximum height of the shoe are located to one side of a longitudinal plane of the shoe, while a flat widening of the shoe occurs on the other side of the longitudinal plane, thereby creating a shoe that is specifically intended for either the left or right foot of a dancer.

The Minden '618 reference sets forth a dance shoe having a toe box that is integrally formed with a shank. Within the toe box are removable foam pads that may be located in at least one of the left and right side surfaces of the toe box, against both the left and right side surfaces of the toe box, or covering the top surface and the left and right side surfaces of the toe box. The foam pads are composed of a dynamic foam pad with a low-compression set, such that the foam pad is compressed by a dancer's foot when the foot is in the flat standing position and expands when the dancer is standing en pointe.

The Minden '069 reference sets forth a ballet slipper having a shank and toe box molded from a thermoplastic polymeric material. The toe box is composed of a platform exterior surface at the forward end of the toe box, a curved radius exterior surface joining the platform, and the lower surface of the shank. The shoe further discloses a layer of resilient, shock-absorbing polymeric material that covers at least a portion of at least one of the lower surfaces of the shank, the exterior surface of the platform, and the exterior surface of the radius of the toe box.

The Gaynor reference sets forth a ballet slipper having a shank and toe box molded from a thermoplastic polymeric material. When the thermoplastic polymeric material is heated, the material softens, thereby allowing the dancer to adjust the shank and toe box to his or her foot. The toe box includes a platform at its forward end and a curved radius

joining the platform and the toe box. The ballet slipper has a polymeric material that lines the interior portion of the toe box and extends backwards from the edges of the toe box. A shock-absorbing polymeric material covers the exterior surface of the curved radius and the platform.

Additionally, there have been several general-footwear companies that have focused on caring for feet by providing footwear and foot bed inserts that conform to the shape of the wearer's foot for the purposes of walking or running. Such general footwear, which include sandals, clogs, ski boots, skates, and shoes, is constructed to match the shape of the wearer's foot. The general footwear and foot bed inserts are designed so that when the wearer is walking upright, the wearer's foot is in as natural a position as it would be if the wearer were walking barefoot.

One example of this type of general footwear is the BIRKENSTOCK® sandal, manufactured by Birkenstock Orthopadie of Germany. In addition to being in the shape of a regular foot, the BIRKENSTOCK® sandal has a natural-shaped footbed that allows room for the foot to maintain a normal position while walking. Additionally, a BIRKENSTOCK® sandal usually implements a raised toe bar. The toe bar encourages the natural gripping motion of the wearer's foot, exercises the legs, and improves circulation while the wearer is walking. The BIRKENSTOCK® sandal further contains an arch support that ensures even weight distribution and proper support of the wearer's foot. Finally, the BIRKENSTOCK® sandal contains a deep heelcup, which keeps the foot's natural padding directly under the heelbone. The toe bar, arch support, and deep heelcup are all provided in order to match the shape of the sandal with the shape of the wearer's foot.

The DR. SCHOLL'S® exercise sandal, manufactured by Scholl, Inc., a Delaware corporation, implements a contoured heel and toe grip. The heel and toe grip are provided to strengthen wearers' legs, feet, and ankles as they walk. The bottom half of the sandal is usually made of wood, and the sandal is manufactured such that wearers must grip the sandals with their toes when walking to ensure that the sandals do not slip off easily.

As a whole, the above-mentioned prior art is incapable of and improper for use in a ballet dance setting; it fails to provide the proper support to ballet dancers' feet, toes, and ankles during en pointe dancing; and it does not retain the aesthetic appearance of a traditional toe shoe.

#### BRIEF SUMMARY OF THE INVENTION

The present invention is directed to a toe shoe, and more specifically, to a toe shoe capable of providing support to a ballet dancer's foot during en pointe dancing.

All of the embodiments of the toe shoe of the present invention preferably include a toe box in the toe of the toe shoe, an upper, an outer sole, and a support structure. The support structure, preferably located within the toe shoe, may include a longitudinal support member, a foot encircling tubular sleeve, and/or a toe ridge. In a first preferred embodiment, the support structure is a longitudinal support member, foot encircling tubular sleeve, and toe ridge. In a second preferred embodiment, the support structure is a longitudinal support member and tubular sleeve. A third preferred embodiment of the present invention is a toe shoe with a support structure including a longitudinal support member and toe ridge.

The foregoing and other objectives, features, and advantages of the invention will be more readily understood upon consideration of the following detailed description of the invention, taken in conjunction with the accompanying drawings.

#### BRIEF DESCRIPTION OF THE SEVERAL VIEWS OF THE DRAWINGS

FIG. 1 shows a first exemplary interior perspective view of a first exemplary embodiment of a toe shoe in accordance with the present invention.

FIG. 2 shows a second exemplary interior perspective view of the first exemplary embodiment of the toe shoe in accordance with the present invention.

FIG. 3 shows a first exemplary interior perspective view of a second exemplary embodiment of the toe shoe in accordance with the present invention.

FIG. 4 shows a second exemplary interior perspective view of the second exemplary embodiment of the toe shoe in accordance with the present invention.

FIG. 5 shows a side perspective view of the first exemplary embodiment of a toe shoe in accordance with the present invention.

FIG. 6 shows a side perspective view of the second exemplary embodiment of a toe shoe in accordance with the present invention.

FIG. 7 shows a side perspective view of a third exemplary embodiment of a toe shoe in accordance with the present invention.

#### DETAILED DESCRIPTION OF THE INVENTION

The present invention is directed to a toe shoe, and more specifically, to a toe shoe capable of providing support to a ballet dancer's foot, toes, and ankle during en pointe dancing. The preferred embodiments of the toe shoe of the present invention are designed to divert forces acting directly on a ballet dancer's foot, toes, and ankle. The preferred embodiments of the toe shoe of the present invention are further designed to retain the aesthetic shape and appearance of the traditional toe shoe commonly known and used in the art.

The present invention is directed generally to a toe shoe incorporating a support structure. The support structure may include a longitudinal support member, a toe ridge, and/or a foot encircling tubular member. In the exemplary embodiments described herein, the support structure may be enclosed in a traditional toe shoe upper. FIGS. 1, 2, and 5 show a first exemplary embodiment of the toe shoe 100 of the present invention having a toe box 5, longitudinal support member 40, foot encircling tubular sleeve 50, and a toe ridge 45. FIGS. 3, 4, and 6 show a second exemplary embodiment of the toe shoe 200 of the present invention having a toe box 5, longitudinal support member 40, and a foot encircling tubular sleeve 50. FIG. 7 shows a third exemplary embodiment of the toe shoe 300 of the present invention, having a toe box 5, a longitudinal support member 40, and a toe ridge 45.

##### A. Toe Shoe Elements

###### 1. Toe Box

The toe shoe of the present invention includes a toe box 5, which is shown in FIGS. 2, 3, and 4, as having a left side 10 a right side 15 an upper surface 20 a lower surface 25 and a forward end 30. The forward end 30 of the toe box 5 provides a platform for the ballet dancer to maneuver on while dancing en pointe, and may be curved or flattened.

In an optional embodiment of the toe box 5 of the present invention, the toe box 5 is adjustable ("adjustable toe box"). To create the adjustable toe box 5, which is shown in FIG. 1, the toe box 5 is sectioned such that there is a left side flap 10, upper flap 20, and a right side flap 15.

## 5

There are many methods of closing the adjustable toe box 5. In a first preferred method, at least one hole or slit is inserted into the left side flap 10, right side flap 15, and upper flap 20 of the toe box 5. At least one nylon, elastic, steel, kevlar, cotton, rubber, plastic, neoprene, or silk lace (hereinafter "lace") 35, may be intertwined between the at least one hole of the left side flap 10 and the upper flap 20. Similarly, at least one lace 35 may be intertwined between the at least one hole in the right side flap 15 and the upper flap 20. In this preferred method, when the left side flap 10 and upper flap 20 are intertwined by the at least one lace 35, and the right side flap 15 and upper flap 20 are intertwined by the at least one lace 35, an adjustable toe box 5 as shown in FIG. 1 is formed. In a closed position, the adjustable toe box 5 can be any shape as long as there is a suitable structure into which the ballet dancer's foot can be inserted. The at least one lace 35 of the adjustable toe box 5 may be individually tightened to fit the adjustable toe box 5 securely around a ballet dancer's foot. To individually tighten the at least one lace 35 of the adjustable toe box 5, the ballet dancer may fully insert her foot into the toe shoe 100, 200, 300, and tighten the at least one lace 35 around the metatarsal bones of her foot. In an optional preferred embodiment, the ballet dancer rolls down the upper 75, which will be further discussed below, in order to tie the at least one lace 35 around the metatarsal bones of her foot. The dancer then tucks the at least one lace 35 of the adjustable toe box 5 into the upper 75 of the toe shoe 100, 200, 300 and rolls up the upper 75.

The toe box 5 of the toe shoe 100, 200, 300 of the present invention may be assembled using layers of fabric, burlap, cardboard, paper, leather saturated with glue, polymer materials, any combination of these materials, or any other suitable material.

## 2. Longitudinal Support Member

The toe shoe 100, 200, 300 of the present invention includes a longitudinal support member, shown in FIGS. 1-7 as a shank 40. Preferably, the shank 40 extends rearward from the toe box 5. The shank 40 may be considered a longitudinal support member because it supports the arch of the ballet dancer's foot while the dancer is en pointe. The shank 40 may take any shape commonly known and used in the art. In FIGS. 1, 2, 3, and 4, the shank 40 is shown as having an upper surface 42 and lower surface 44. In a preferred embodiment, the shank 40 is connected to the lower surface 25 of the toe box 5. "Connected" may mean integral, attached directly, attached indirectly, or attachable.

The shank 40 may be manufactured in varying strengths. For example, if a ballet dancer has a flexible or weak foot, the shank 40 may be constructed from stiff materials that support the arch of the dancer's foot. If a ballet dancer has a strong or relatively inflexible foot, the shank 40 may be constructed from more compliant materials so that the dancer's foot may arch without inhibition. Further, the shank 40 may be formed with laminations or an internal opening. A shank 40 formed with laminations or an internal opening may be comprised of varying materials. For example, a first set of laminations may be comprised of layers of fabric, while a second set of laminations may be comprised of cardboard.

The length of the shank 40 may vary based on the type of support desired by the ballet dancer. If full support is desired through the arch of the dancer's foot, the shank 40 may be extended to run the length of the foot, as shown in FIGS. 5 and 6. A half-shank or three-quarter-length shank may also be used.

The shank 40 may be manufactured from commonly known materials including, but not limited to, bamboo,

## 6

wood, leather, cardboard, steel, plastic, metal, polymer materials, any combination of these materials, or any other suitable materials. In one preferred embodiment, the shank 40 is manufactured from a metal strip such as beryllium copper. In another preferred embodiment, the shank 40 is manufactured from a polymer or plastic strip. The polymer or plastic strip may be polycarbonate, any other type of synthetic thermoplastic resin, any combination of these materials, or any other suitable support materials.

## 3. Toe Ridge

A toe ridge 45 is included in the first and third exemplary embodiments of the toe shoe 100, 300 of the present invention. The toe ridge 45 is preferably located rearward from the toe box 5. The purpose of the toe ridge 45 is to give the ballet dancer's foot purchase under the knuckles of her toes. The toe ridge 45 provides a grip for the dancer's foot and reduces lateral spreading of the foot and toes in the toe box 5, thereby preventing excessive lateral spreading when the ballet dancer is en pointe. Reducing the lateral spreading of the dancer's foot and toes while en pointe decreases the amount of stress placed on the dancer's foot and toes. Further, by not compressing the foot into the toe box 5 the foot is kept in proper alignment while dancing en pointe and is retained in, nearly the same position that the foot would have been in had the ballet dancer been standing flat-footed.

It is preferred that the toe ridge 45 be positioned beneath the underside of the ballet dancer's toes. Specifically, it is preferred that the toe ridge 45 be located beneath the proximal phalanges located in the foot. This position is preferred because when the dancer is dancing en pointe, the toe ridge 45 will provide a purchase that will retain the dancer's foot in the most natural position. The position is also preferred because when the dancer is not en pointe, the toe ridge 45 will be located beneath the proximal phalanges, thereby allowing the dancer to perform without feeling any discomfort to the underside of the dancer's foot.

The toe ridge 45 may be shaped in different ways to provide an optimal fit and comfort to a ballet dancer. The toe ridge 45 may be a solid bar, substantially semicircular in cross-section. Alternatively, the toe ridge 45 may have a shape more specific to the shape of the dancer's toes. In this alternate embodiment, the toe ridge 45 will have a general structure that would, through use, conform to the exact shape beneath the proximal phalanges of the dancer's foot when the dancer is en pointe. Further, in an adjustable embodiment, the toe ridge 45 may be inflated into a comfortable form. In this adjustable embodiment, the toe ridge 45 is essentially a bladder, whereby a dancer may inflate the toe ridge 45 with support material prior to dancing en pointe until the toe ridge 45 is at an optimal position for the dancer. In another embodiment, the ballet dancer could be provided with a set of toe ridges 45 having different shapes. Based on the type of dance the dancer were performing or the type of stage the dancer were performing on, the dancer could pick the most comfortable toe ridge 45 and attach it between the shank 40 and the outer sole 85, to the shank 40, or between the laminations or through the internal opening of the shank 40, depending on the type of shank contained in the toe shoe 100, 300. Still further, a custom embodiment provides a custom-made toe ridge 45. In this custom embodiment, the area between the ground and the proximal phalanges would be measured for each individual ballet dancer. Based on the measurements, a toe ridge 45 would be created that would conform directly to the area between the ground and the dancer's proximal phalanges.

The toe ridge 45 may be constructed from materials such as leather, cardboard, wood, burlap, fabric, plastic, a combination of these materials, or any other suitable material.



#### 4. Foot Encircling Tubular Sleeve

A foot encircling tubular sleeve is included in the first and second exemplary embodiments of the toe shoe **100**, **200** of the present invention, and is shown in FIGS. 1–6 as a sling **50**, **250**. The sling **50** should circumferentially envelop the metatarsal bones of a ballet dancer's foot. The sling **50** diverts the forces acting directly on the dancer's toes, foot, and ankle throughout the ballet dancer's body. Further, in the first embodiment of the toe shoe **100** of the present invention, the sling **50** ensures that the toe ridge **45** remains in useful contact with the underside of a dancer's foot.

There are three preferred embodiments of the sling **50**. In the first preferred embodiment of the sling **50**, which is shown in FIG. 2, the sling is a closed sling ("closed sling"). In the second preferred embodiment of the sling shown in FIGS. 1 and 3, the sling **50** is integrally connected with a coupler **55** ("coupler sling"). In the third preferred embodiment shown in FIG. 4, the sling **50** is integrally connected with the toe box ("toe box sling").

In order to create the closed sling **50** shown in FIG. 2, a rectangular piece of sling material is attached underneath and lies transverse to the shank **40** such that a first flap **60** and second flap **65** of sling material extend from both sides of the shank **40**. The first flap **60** and second flap **65** of sling material may be raised in the direction of the arrows in FIG. 2 and closed, thereby forming a sling **50**. In its closed position, the sling **50** should be tubular, which can be almost any shape as long as it is a suitable structure through which a ballet dancer's foot can pass.

There are many methods of closing the sling **50** as shown in FIG. 2. At least one hole **70** may be inserted into both the first flap **60** and the second flap **65** of sling material (the "tying method"). At least one lace **35** may be intertwined between the at least one hole **70** of the first flap **60** and second flap **65** of sling material. If using the tying method for closing the sling **50**, it is preferred that when the first flap **60** and second flap **65** of sling material are raised in the direction of the arrows in FIG. 2, at least one lace **35** be tied, thereby forming a sling **50** as shown in FIG. 2. In an optional embodiment of the tying method, the at least one lace **35** of the sling **50** is individually tightened to fit securely around a ballet dancer's foot. To individually tighten the at least one lace **35** of the sling **50**, a dancer inserts her foot into the toe shoe and ties the at least one lace **35** around the metatarsal bone of her foot. The dancer then tucks the at least one lace **35** into an upper **75** of the toe shoe **100**, while pulling a heel portion of the shoe over the heel of the dancer's foot.

In an alternate method for closing the sling **50** as shown in FIG. 2, the first flap **60** and second flap **65** of sling material may be raised in the direction of the arrows in FIG. 2 and tied with at least one lace **35**, hook and loop fastened, glued, nailed, melted, or welded together (the "fastening method"). Any combination of tying with at least one lace **35**, hook and loop fastening, gluing, melting, welding, or nailing may be used, along with any other suitable method for securing the first flap **60** and second flap **65** of sling material together to form a sling **50**. If the fastening method is used, it is preferred that the fastening of the first flap **60** and second flap **65** of the sling material occur during the manufacturing process of the toe shoe **100**, thereby allowing for a variety of sizes and shapes of slings **50** to be formed and inserted into the toe shoe prior to the ballet dancer placing her foot into the toe shoe **100**. Further, if the sling is inserted prior to the ballet dancer placing her foot into the toe shoe **100**, the materials making up the sling **50** may be of a kind that shrink when heated or damp, so that a ballet dancer wearing the toe shoe **100** during a practice or

performance will feel a snugness across the metatarsal bones of her foot due to a shrinking of the sling material. If a shrinkable material is not used, the toe shoe **100** may be incrementally sized in both the length of the dancer's foot and circumferentially transverse the length of the metatarsal area of the dancer's foot. The dancer would specify both a length and a sling size when specifying the toe shoe size.

The second preferred embodiment of the sling is shown in FIGS. 1 and 3, wherein the sling **50** is integrally connected with a coupler **55** ("coupler sling"). In order to create the coupler sling **50** shown in FIGS. 1 and 3, a coupler **55** must extend forward from the coupler sling **50**. The coupler **55** is the connective structure between the toe box **5** and the coupler sling **50**. As with the coupler sling **50**, the coupler **55** may be made of ballistic cloth, leather, cardboard, wood, neoprene, rubber, nylon, silk, metal, burlap, fabric, plastic, any combination of these materials, or any other suitable material. In a preferred embodiment, the coupler **55** and the longitudinal support member **40** are made from the same material.

The toe box **5** may be relieved to fit with the coupler **55**. Alternatively, the lower surface **25** of the toe box **5** and the coupler **55** may be connected by gluing, nailing, melting, or welding. Any combination of gluing, melting, welding, or nailing may be used, along with any other suitable method for connecting the lower surface **25** of the toe box **5** with the coupler **55**. In another alternative, the coupler **55** may be a longitudinal support member, or a combination of the coupler **55** and the shank **40** may form a longitudinal support member.

In creating the coupler sling **50**, a rectangular piece of sling material is transversely connected to the coupler **55**, such that a first flap **60** and second flap **65** of sling material extend from both sides of the coupler **55**. The first flap **60** and second flap **65** of sling material may be raised in the direction of the arrows in FIG. 3 and closed, thereby forming the coupler sling **50**. In a closed position, the coupler sling **50** should be tubular, which can be any shape as long as there is a suitable structure through which the ballet dancer's foot can pass.

As with the closed sling **50** embodiment of the sling **50** of the present invention, the coupler sling **50** may be closed using either the tying method or fastening method, which are discussed above.

The third preferred embodiment of the sling **50** is shown in FIG. 4 as a toe box sling **50**. To create the toe box sling **50**, a piece of sling material is integrally connected to and extends rearward from the toe box **5**. Preferably, the sling material is sectioned such that there is a left side flap **10**, upper flap **20**, and a right side flap **15**.

There are many methods of closing the toe box sling **50**. In a first preferred embodiment, at least one hole or slit is inserted into the left side flap **10**, right side flap **15**, and an upper flap **20**. At least one lace **35** may be intertwined between the at least one hole of the left side flap **10** and upper flap **20** of sling material. Similarly, at least one lace **35** may be intertwined between the at least one hole in the right side flap **15** and upper flap **20** of sling material. In this preferred embodiment, when the left side flap **10** and upper flap **20** of sling material are intertwined, and the right side flap **15** and upper flap **20** of sling material are intertwined, a toe box sling **50**, as shown in FIG. 4, is formed. In a closed position, the toe box sling **50** should be tubular, which can be any shape as long as there is a suitable structure through which the ballet dancer's foot can be inserted. The at least one lace **35** of the toe box sling **50** may be individually tightened to fit the toe box sling **50** securely around a ballet

dancer's foot. To individually tighten the at least one lace of the toe box sling **50**, the ballet dancer fully inserts her foot into the toe shoe, and tightens the at least one lace **35** around the metatarsal bones of her foot. In an optional preferred embodiment, the ballet dancer may roll down the upper **75**, which will be further discussed below, in order to tie the laces **35** around the metatarsal bones of her foot. The dancer then tucks the laces of the toe box sling **50** into the upper **75** of the toe shoe **200**, and rolls up the upper **75**.

The sling **50** may be composed of ballistic cloth, leather, cardboard, wood, metal, burlap, fabric, plastic, neoprene, rubber, nylon, silk, any combination of these materials, or any other suitable material (hereinafter "sling material"). In one preferred embodiment, the sling material allows the sling to flex based on movements of the dancer's foot.

#### 5. Upper

The upper **75** of the toe shoe of the present invention is shown in FIGS. **5-7**. The upper **75** is aesthetically similar to a traditional toe shoe, covering the toe box **5** and more generally the front of the ballet dancer's foot. The upper **75** may then extend along either side of the ballet dancer's instep and around the ballet dancer's heel. It is preferred that the upper **75** tightly encase both the toe box **5** and shank **40**. The upper **75** may further contain a cotton, elastic, or silk drawstring cuff **80** around the edge of the shoe to allow for individual fitting of the toe shoe **100, 200, 300** to the ballet dancer's foot.

The upper **75**, which is commonly known in the art, may be composed of materials commonly used in the art, including, but not limited to, fabrics such as silk, canvas, rayon, satin, any combination of these materials, or any other suitable materials.

#### 6. Outer Sole

The toe shoe of the present invention further contains an outer sole **85**, which is shown in FIGS. **5-7**. The outer sole **85** provides a non-slip surface for the ballet dancer's foot when it comes into contact with the floor. Further, the outer sole **85** allows a dancer to grip and feel the floor while practicing or performing. The outer sole **85** may be attached to the bottom of the upper **75** using any method commonly known in the art, including but not limited to gluing or sewing. While the outer sole **85** may be as thick as desired, in a preferred embodiment the outer sole **85** is thin enough to allow a ballet dancer to feel the dance floor when dancing. The outer sole **85** may be formed with laminations or an internal opening. An outer sole **85** formed with laminations or an internal opening may be comprised of varying materials. For example, the first set of laminations may be comprised of fabric, while the second set of laminations may be comprised of cardboard. Finally, the outer sole **85** may be the same size as the toe shoe **100, 200, 300**, or narrower and shorter than the dancer's foot. Further, the outer sole **85** may be in two pieces, thereby freeing the arch of the foot and allowing for plantar flexion while a ballet dancer is en pointe.

The outer sole **85** of the toe shoe **100, 200, 300** of the present invention may be composed of any material capable of flexing, including suede, buffed leather, scored leather, plastic, fabric, any combination of these materials, or any other suitable materials.

#### 7. Ribbon

If desired, at least one ribbon, lace, or elastic strip (hereinafter "ribbon") **90** may be attached to the toe shoe **100, 200, 300** of the present invention in any method commonly known by persons having skill in the art. The at least one ribbon **90** may be wound, tied, or secured by the ballet dancer around the dancer's legs and/or ankles, pro-

viding both additional support to the dancer's foot and aesthetic similarity to the traditional toe shoe.

The at least one ribbon **90** may be composed of silk, silk with elastic, elastic, any combination of these materials, any material commonly known and used by others having skill in the art, or any other suitable materials.

#### B. Exemplary Embodiments

FIG. **5** shows the first exemplary embodiment of the toe shoe **100** of the present invention. The toe shoe **100** has a toe box **5**, longitudinal support member **40**, toe ridge **45**, foot encircling tubular sleeve **50**, upper **75**, outer sole **85**, and optional ribbon **90**. Extending rearward from the toe box **5** is a longitudinal support member shown as a shank **40**.

A toe ridge **45** is preferably located rearward from the toe box **5**. As stated above, it is preferred that the toe ridge **45** be positioned beneath the underside of the ballet dancer's toes. Specifically, it is preferred that the toe ridge **45** be located beneath the proximal phalanges located in the foot.

It is further preferred that the toe ridge **45** be attached to the toe shoe **100** between the shank **40** and the outer sole **85**. In a first preferred embodiment, the toe ridge **45** is joined with a shank **40** having laminations or an internal opening. "Joined" may mean integral, permanently incorporated, adjustable, replaceable, or movable. In a second preferred embodiment, the optional toe ridge **45** is permanently incorporated as part of the shank **40**. In a third preferred embodiment, the optional toe ridge **45** is adjustable. An adjustable toe ridge **45** allows for the placement of the toe ridge **45** in any desired position along the shank **40**. Further, an adjustable toe ridge **45** allows the toe ridge **45** to be suitably fitted to a ballet dancer's foot based on the length and shape of the foot. In a fourth preferred embodiment, the optional toe ridge **45** is replaceable. When the toe ridge **45** becomes worn down, or if the toe ridge is too large or too small for a ballet dancer, the replaceable toe ridge **45** may be removed from the toe shoe **100** and replaced with a desired toe ridge **45**. In a fifth preferred embodiment, a movable, clamp or spring-type attachment may be located below the optional toe ridge **45**, thereby allowing the toe ridge **45** to move up and down the shank **40** based on the position of the ballet dancer's foot within the toe shoe **100**.

Located rearward of the toe ridge **45** is a foot encircling tubular sleeve, which is shown in FIG. **5** as a sling **50**. There are a number of preferred embodiments for attaching the sling **50** to the shank **40**. "Attached," as used for purposes of the first exemplary embodiment of the toe shoe **100** of the present invention, may mean permanently incorporated, adjustable, replaceable, or movable. In a first preferred embodiment, the sling **50** is permanently incorporated into the shank **40**. In a second preferred embodiment, the sling **50** is adjustable. The adjustable embodiment allows for the sling **50** to be placed in any desired position along the shank **40**. The adjustable embodiment further allows the sling **50** to be suitably fitted to a ballet dancer's foot based on the varying lengths and shapes of her foot. In a third preferred embodiment, the sling **50** may be tied to the outer sole **85** or shank **40**. At least one lace is passed through at least one hole located in the sling **50** and through at least one hole located in either the shank **40** or outer sole **85** of the toe shoe **100**. The sling **50** may fit above or below the shank **40** or outer sole **85**. In a fourth preferred embodiment, the shank **40** or outer sole **85** has been formed with laminations or an internal opening, and the sling **150** passes through the internal opening or between the at least two layers of the shank **40** or outer sole **85**. In a fifth preferred embodiment, the sling **50** is replaceable. If the sling **50** becomes worn down, or if the sling **50** is too large or too small for the ballet

dancer's foot, the sling **50** may be removed from the toe shoe **100** and replaced with a new or properly fitting sling **50**.

Preferably, the toe box **5**, shank **40**, toe ridge **45**, and sling **50** are enclosed by an upper **75**. Preferably attached to the bottom of the upper **75** is an outer sole **85**. If desired, at least one ribbon, lace, or elastic strip (hereinafter "ribbon") **90** may be attached to the first exemplary embodiment of the toe shoe **100** of the present invention in any method commonly known by persons having skill in the art.

Referring now to FIGS. **3** and **6**, a second exemplary embodiment of the toe shoe **200** of the present invention is shown. The toe shoe **200** has a toe box **5** Located rearward of the toe box **5** is a support structure in the form of a foot encircling tubular sleeve, which is shown in FIGS. **3** and **6** as a sling **50**.

A longitudinal support member, which is shown in FIGS. **3** and **6** as a shank **40**, extends rearward from the forward end **30** of the toe box **5** and may be located over the lower surface **25** of the toe box **5**, and the sling **50**. Preferably, the shank **40** has an upper surface **42** and lower surface **44**. In one preferred embodiment, the lower surface **25** of the toe box **5** is connected to the upper surface **42** of the shank **40**. "Connected" may mean integral, attached directly, attached indirectly, or attachable. The lower surface **25** of the toe box **5**, and the sling **50** may be connected to the shank **40** using methods and materials commonly known in the art such as using small nails, sewing, or gluing. In another preferred embodiment, especially where the coupler sling **50** is used, the longitudinal support member is a combination of the shank **40** and the coupler **55**.

In a preferred embodiment, the shank **40**, toe box **5**, and sling **50** are surrounded by an upper **75**. As with the first embodiment, it is preferred that an outer sole **85** be attached to the bottom of the upper **75**. If desired, at least one ribbon **90** may be attached to the toe shoe **200** in the methods such as those discussed for the at least one ribbon **90** of the first exemplary embodiment of the toe shoe **100** of the present invention.

FIG. **7** shows the third exemplary embodiment of the toe shoe **300** of the present invention. The toe shoe **300** has a toe box **5** such as the toe box **5** discussed in the first exemplary embodiment of the toe shoe **100** of the present invention.

Preferably extending rearward from the toe box **5** is a longitudinal support member shown in FIG. **7** as a shank **40**. The shank **40** of the third exemplary embodiment may be manufactured and connected to the toe box **5** using the methods such as those discussed in the first exemplary embodiment of the toe shoe **100** of the present invention.

A toe ridge **45** is located rearward from the toe box **5**. The toe ridge **45** of the third exemplary embodiment may be attached, constructed, shaped, and located using the methods such as those discussed for the toe ridge **45** in the first exemplary embodiment of the toe shoe **100** of the present invention.

In a preferred embodiment, the shank **40**, toe box **5**, and toe ridge **45** are surrounded by an upper **75**. As with the first and second exemplary embodiments of the toe shoes **100**, **200** of the present invention, it is preferred that attached to the bottom of the upper **75** is an outer sole **85**. As with the first and second exemplary embodiments of the toe shoes **100**, **200** of the present invention, at least one ribbon **90** may be attached to the toe shoe **300** in the methods such as those discussed for the at least one ribbon **90** of the first and second exemplary embodiments of the toe shoes **100**, **200** of the present invention.

#### C. Miscellaneous

Although the description and drawings generally describe a toe shoe worn by a female, it is to be understood that the

present invention describes a toe shoe that can be worn by either male, female, child, or adult. The terms "her," "she," "ballet dancer," and "female" as used in the description of the invention are for descriptive purposes only and are not intended to limit the scope of the invention.

It is to be further understood that the description and drawings generally describe a toe shoe that can be fitted to either the left or right foot, and the present invention encompasses a toe shoe, whether made as a pair for a left and right foot or as individual toe shoes made for use on either foot.

The terms and expressions used in the foregoing specification are used as terms of description and not of limitation, and are not intended to exclude equivalents of the features shown and described or portions of them. The scope of the invention is defined and limited only by the claims that follow.

What is claimed is:

1. A toe shoe, said toe shoe comprising:

- (a) a toe box;
- (b) a shank;
- (c) said shank connected to said toe box and extending rearward from said toe box;
- (d) an adjustable foot-encircling tubular sleeve, said foot-encircling tubular sleeve incorporated in said toe shoe and positioned rearward from said toe box;
- (e) an upper;
- (f) said toe box, said shank, and said tubular sleeve enclosed within said upper;
- (g) an outer sole; and
- (h) said outer sole extending at least partially along said upper.

2. The toe shoe of claim **1**, said toe box being an adjustable toe box and said toe shoe further comprising:

- (a) an upper;
- (b) said toe box, said shank, and said foot encircling tubular sleeve enclosed within said upper;
- (c) an outer sole; and
- (d) said outer sole extending at least partially along said upper.

3. The toe shoe of claim **1**, wherein said foot-encircling tubular sleeve is a sling, said sling is:

- (a) a closed sling;
- (b) a coupler sling; or
- (c) a toe box sling.

4. The toe shoe of claim **3**, said toe shoe further comprising:

- (a) an upper;
- (b) said toe box, said shank, and said sling enclosed within said upper;
- (c) an outer sole; and
- (d) said outer sole extending at least partially along said upper.

5. A toe shoe, said toe shoe comprising:

- (a) a toe box;
- (b) a shank;
- (c) said shank connected to said toe box and extending rearward from said toe box;
- (d) a toe ridge;
- (e) an outer sole;
- (f) said toe ridge attached between said shank and said outer sole, and located rearward from said toe box; and

## 13

(g) an adjustable foot-encircling tubular sleeve, said foot-encircling tubular sleeve incorporated in said toe shoe and positioned rearward from said toe box and said toe ridge.

6. The toe shoe of claim 5, said toe shoe further comprising:

- (a) an upper;
- (b) said toe box, said shank, and said toe ridge enclosed within said upper; and
- (c) said outer sole attached to the bottom of said upper.

7. The toe shoe of claim 5, said toe box being an adjustable toe box.

8. The toe shoe of claim 7, said toe shoe further comprising:

- (a) an upper;
- (b) said adjustable toe box, said shank, and said toe ridge enclosed within said upper; and
- (c) said outer sole attached to the bottom of said upper.

9. A structure for providing support to a ballet dancer's foot while dancing, said structure comprising:

- (a) a toe shoe;
- (b) said toe shoe having a toe end and a heel end;
- (c) said toe end having a toe box incorporated therein;
- (d) an adjustable foot-encircling tubular sleeve, said foot-encircling tubular sleeve incorporated in said toe shoe and located between said toe and said heel end of said toe shoe.

10. The structure of claim 9, said structure further comprising:

- (a) an upper;
- (b) said toe box and said foot encircling tubular member enclosed within said upper;
- (c) an outer sole;
- (d) said outer sole extending at least partially between said toe end and said heel end;
- (e) at least one ribbon; and
- (f) said at least one ribbon being connected to said upper.

11. The structure of claim 9, said support structure further comprising a longitudinal support member, said longitudinal support member and extending at least partially between said toe end and said heel end of said toe shoe.

12. The structure of claim 11, said foot-encircling tubular sleeve comprising:

- (a) a first and a second flap;
- (b) said first and said second flap transverse to said longitudinal support member; and
- (c) said first flap and said second flap being connected together to form a tubular opening.

13. The structure of claim 12, said support structure further comprising a toe ridge, said toe ridge located between said toe end and said foot encircling tubular sleeve.

14. The structure of claim 13, said structure further comprising:

- (a) an upper;
- (b) said toe box and said foot encircling tubular member enclosed within said upper;
- (c) an outer sole;
- (d) said outer sole extending at least partially between said toe end and said heel end;
- (e) at least one ribbon; and
- (f) said at least one ribbon being connected to said upper.

## 14

15. The structure of claim 9, wherein said foot-encircling tubular sleeve is a sling.

16. The structure of claim 15, said sling being integrally connected to and extending rearward from said toe box.

17. The structure of claim 15, further comprising a coupler, said coupler located between and connecting said toe box and said sling.

18. The structure of claim 17, said toe box relieved to fit with said coupler.

19. A support structure for providing support to a dancer's foot during en pointe dancing, said support structure for use within a toe shoe having a toe end and a heel end, said toe end having a toe box incorporated therein, said support structure comprising:

- (a) a longitudinal support member;
- (b) said longitudinal support member extending at least partially between said toe end and said heel end;
- (c) an adjustable foot-encircling tubular sleeve, said foot-encircling tubular sleeve incorporated in said toe shoe;
- (d) said foot-encircling tubular sleeve connectable to said longitudinal support member between said toe end and said heel end; and
- (e) said foot-encircling tubular sleeve being positioned along said longitudinal support member so that during en pointe dancing, said dancer's foot is at least partially supported by said foot-encircling tubular sleeve and said longitudinal support member.

20. The support structure of claim 19, wherein said longitudinal support member is a shank and said foot-encircling tubular sleeve is a sling.

21. The support structure of claim 20, further comprising a toe ridge attached to said shank.

22. The support structure of claim 19, wherein said longitudinal support member is a coupler and said foot-encircling tubular sleeve is a sling.

23. The support structure of claim 19, wherein said longitudinal support member is a combination of a coupler and a shank and said tubular sleeve is a sling.

24. The support structure of claim 19, wherein said longitudinal support member and said foot-encircling tubular sleeve divert forces acting directly on said dancer's toes, feet, and ankles.

25. Support structure for providing support to a dancer's foot while dancing en pointe, said support structure for use with a toe shoe having a toe end and a heel end, said toe end having a toe box incorporated therein, said support structure comprising:

- (a) a longitudinal support member;
- (b) said longitudinal support member extending at least partially between said toe end and said heel end;
- (c) a toe ridge;
- (d) said toe ridge attached to said longitudinal support member between said toe end and said heel end;
- (e) said toe ridge being positioned along said longitudinal support member so that, while dancing en pointe, said dancer's foot is given purchase;
- (f) an adjustable foot-encircling tubular sleeve, said foot-encircling tubular sleeve incorporated in said toe shoe and positioned rearward from said toe ridge.

15

- 26. A toe shoe, said toe shoe comprising:
  - (a) an adjustable toe box;
  - (b) a shank;
  - (c) said shank connected to said toe box and extending rearward from said toe;
  - (d) a toe ridge;
  - (e) an outer sole;
  - (f) said toe ridge attached between said shank and said outer sole, and located rearward from said toe box;
  - (g) an upper;
  - (h) said adjustable toe box, said shank, and said toe ridge enclosed within said upper; and
  - (i) said outer sole attached to the bottom of said upper.
- 27. A structure for providing support to a ballet dancer's foot while dancing, said structure comprising:
  - (a) a toe shoe;
  - (b) said toe shoe having a toe end and a heel end;
  - (c) said toe end having a toe box incorporated therein;
  - (d) a foot-encircling tubular sleeve;

16

- (e) said foot-encircling tubular sleeve located between said toe and said heel end of said toe shoe;
- (f) a longitudinal support member, said longitudinal support member extending at least partially between said toe end and said heel end of said toe shoe;
- (g) said foot encircling tubular sleeve comprising a first and second flap, said first and second flap transverse to a longitudinal support member and connected together to form a tubular opening;
- (h) a toe ridge, said toe ridge located between said toe end and said foot encircling tubular sleeve;
- (i) an upper;
- (j) said toe box and said foot encircling tubular member enclosed within said upper;
- (k) an outer sole;
- (l) said outer sole extending at least partially between said toe end and said heel end;
- (m) at least one ribbon; and
- (n) said at least one ribbon being connected to said upper.

\* \* \* \* \*