



US 20160009389A1

(19) **United States**

(12) **Patent Application Publication**
KURODA et al.

(10) **Pub. No.: US 2016/0009389 A1**

(43) **Pub. Date: Jan. 14, 2016**

(54) **ORNITHOPTER**

Publication Classification

(71) Applicant: **mitsubishi heavy industries, LTD.**, Minato-ku, Tokyo (JP)

(51) **Int. Cl.**
B64C 33/02 (2006.01)

(72) Inventors: **Satoshi KURODA**, Tokyo (JP); **Tomoyuki MORI**, Tokyo (JP); **Kazuya HATTORI**, Tokyo (JP); **Masato TAHARA**, Tokyo (JP); **Oki TAKAYAMA**, Tokyo (JP)

(52) **U.S. Cl.**
CPC **B64C 33/02** (2013.01)

(73) Assignee: **mitsubishi heavy industries, LTD.**, Minato-ku, Tokyo (JP)

(57) **ABSTRACT**

(21) Appl. No.: **14/759,321**

(22) PCT Filed: **Feb. 19, 2014**

(86) PCT No.: **PCT/JP2014/053924**

§ 371 (c)(1),

(2) Date: **Jul. 6, 2015**

An ornithopter includes a main wing mounted on a fuselage, and a control system configured to control a flapping motion of the main wing. The main wing includes an inner spar, an outer spar, and a wrist portion disposed between the inner spar and the outer spar and which varies a bending angle, which is a relative angle between the inner spar and the outer spar, within a predetermined angle range. The control system includes an actuator which performs a raising motion and a lowering motion of the inner spar by moving the inner spar in an upward direction and in a downward direction, an angle sensor which measures the bending angle, and a control unit which controls the actuator to move the inner spar in response to the measured bending angle.

(30) **Foreign Application Priority Data**

Feb. 21, 2013 (JP) 2013-032544

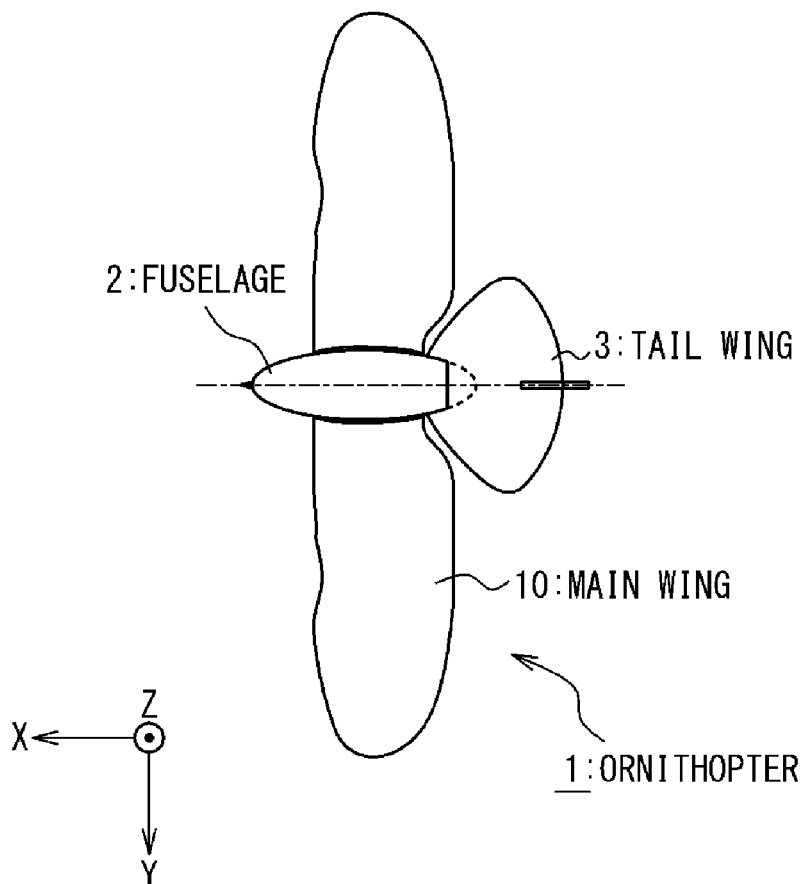

Fig. 1

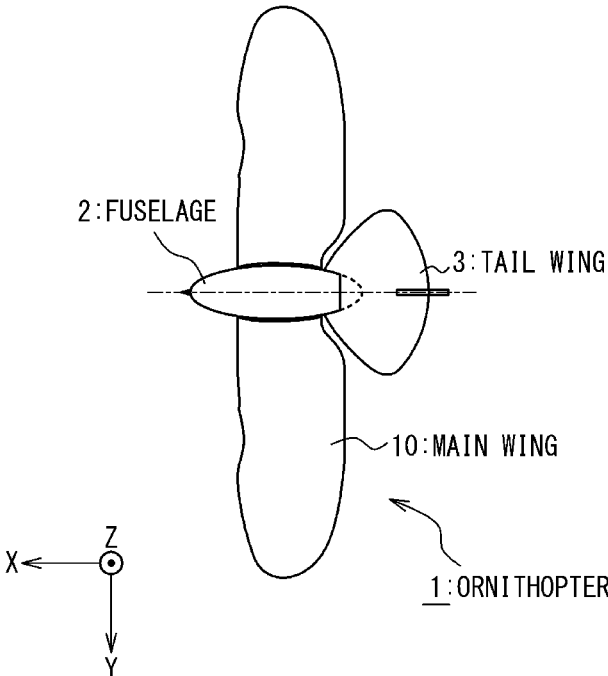

Fig. 2

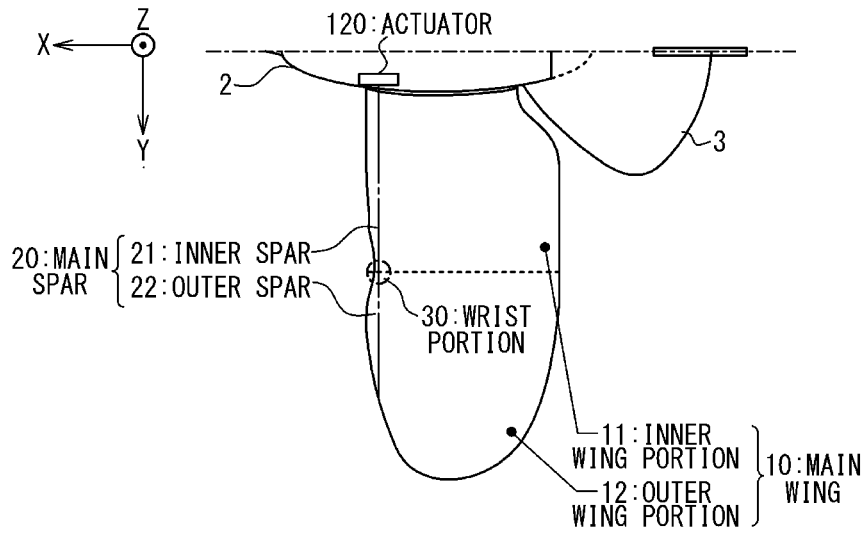

Fig. 3

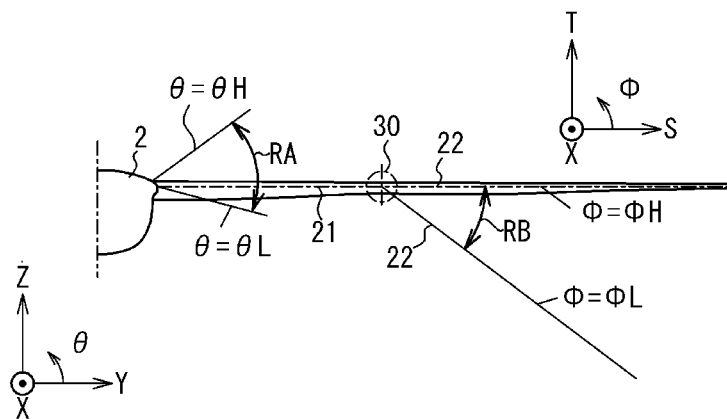

Fig. 4A

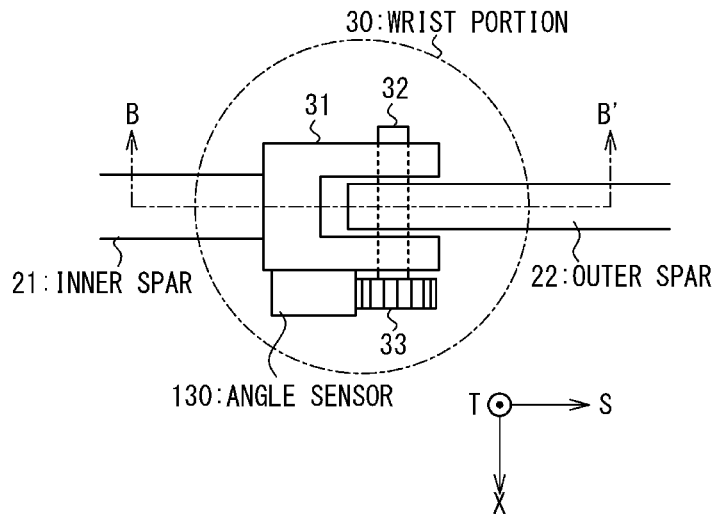

Fig. 4B

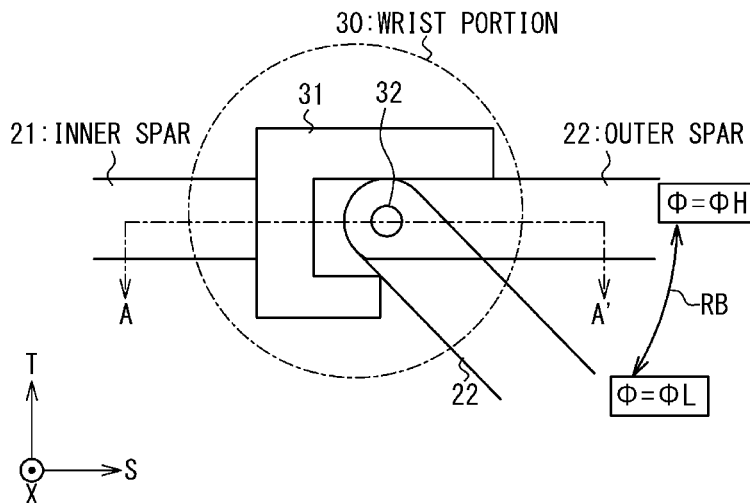

Fig. 5

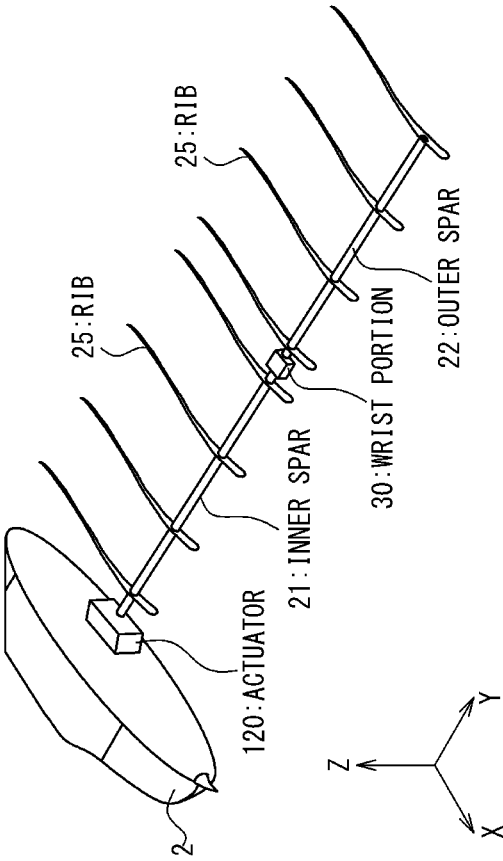

Fig. 6

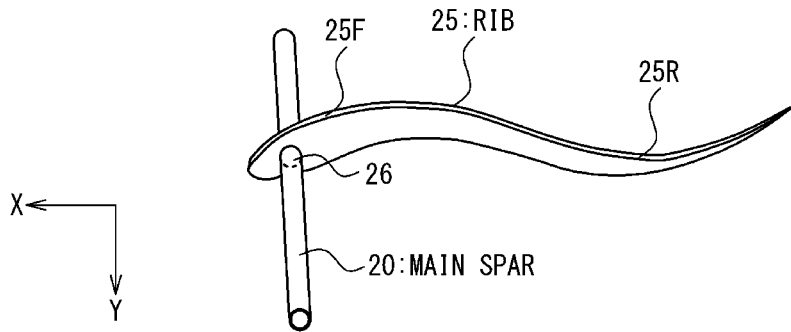

Fig. 7

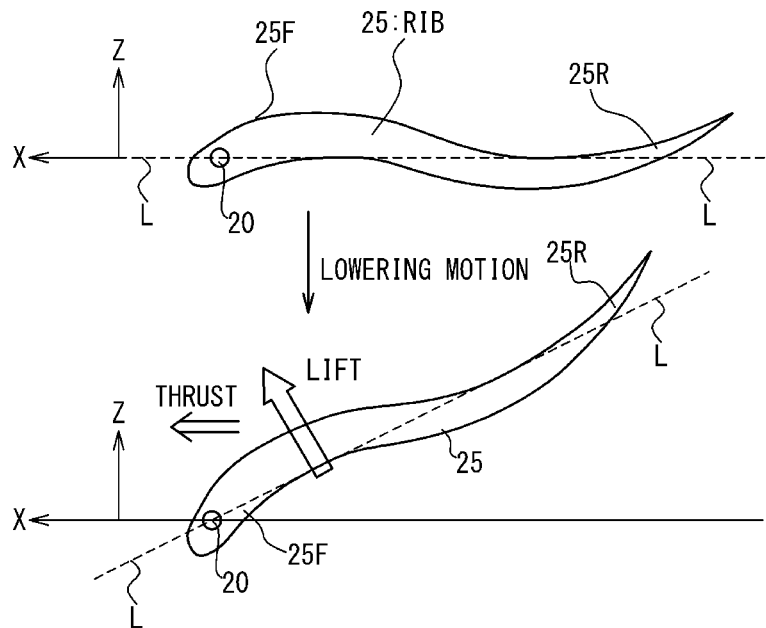

Fig. 8

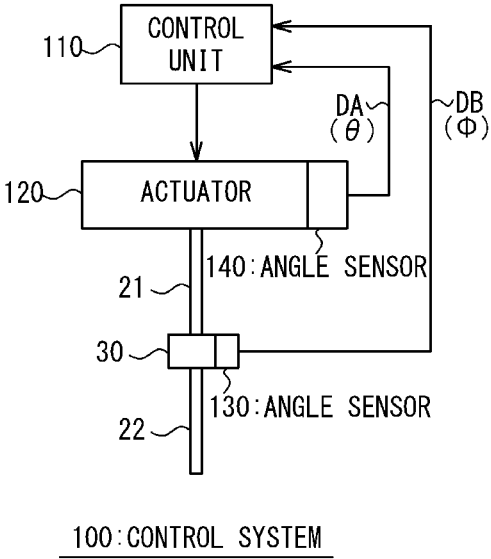

Fig. 9

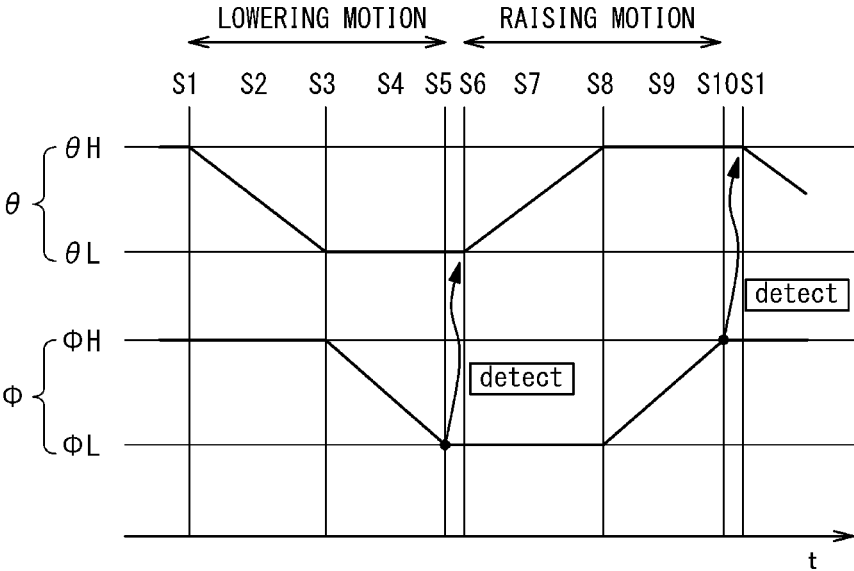

Fig. 10

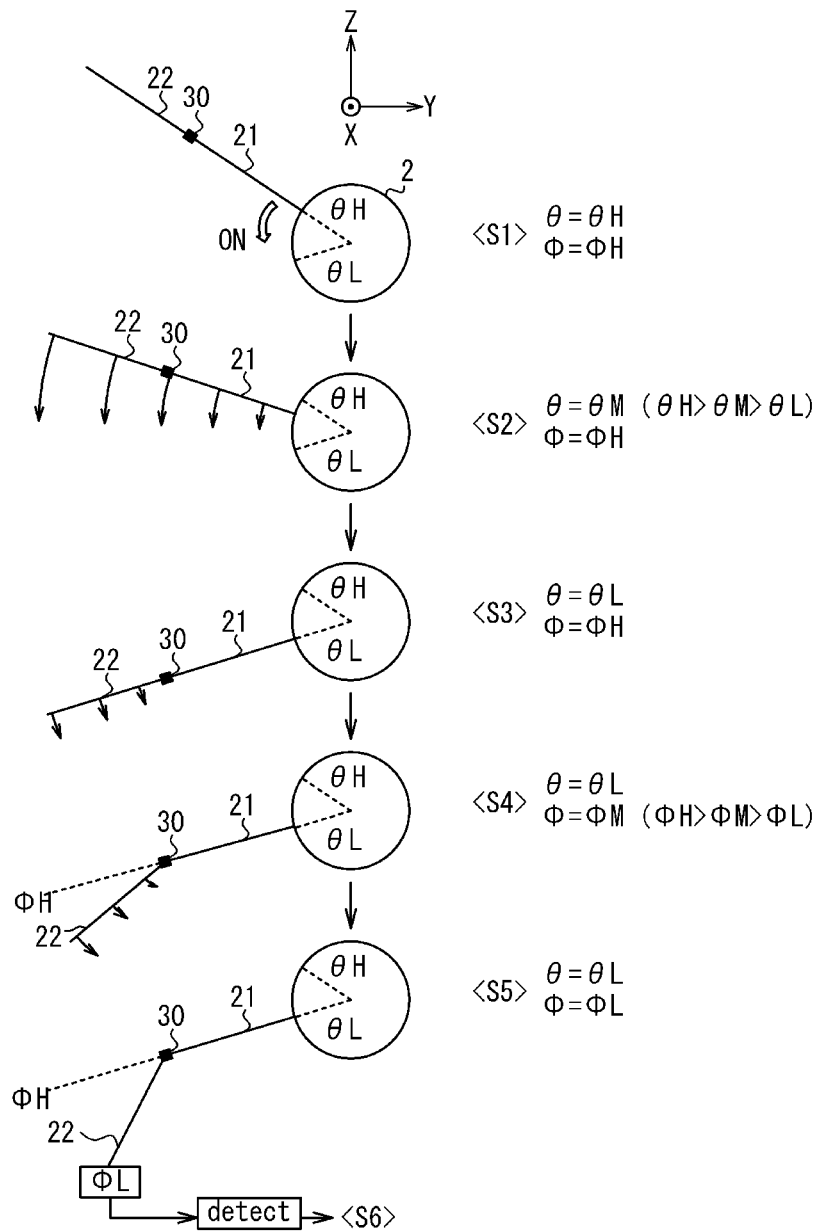

Fig. 11

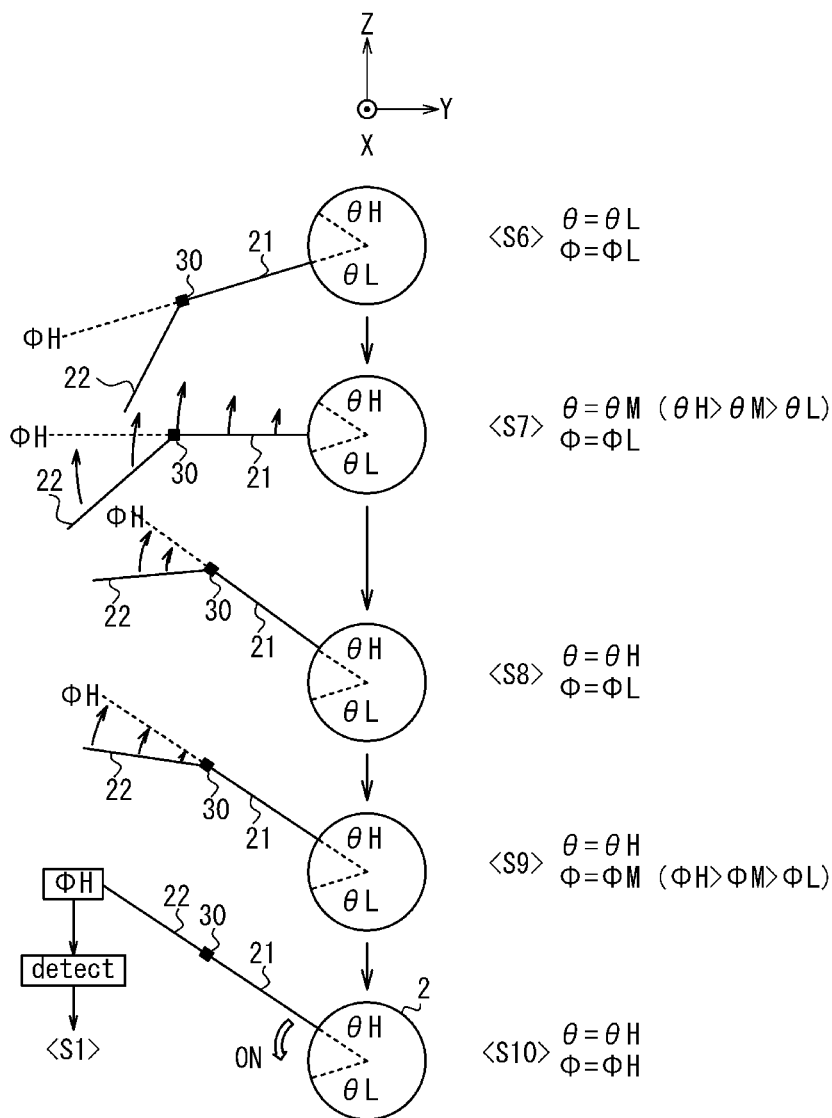
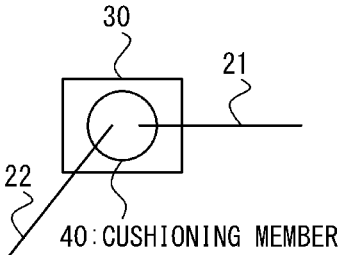

Fig. 12



ORNITHOPTER

TECHNICAL FIELD

[0001] The present invention relates to an ornithopter.

BACKGROUND ART

[0002] A small unmanned air vehicle (UAV) is developed. Such a UAV at the present moment is mainly a fixed wing type or a rotary wing type. However, as a future UAV form, development of “flapping type” which imitates birds or insects is initiated. The flapping type UAV has characteristics of both the fixed wing type and the rotary wing type, and is expected from the viewpoint of quietness, low visibility, mimetic characteristics etc. Such a flapping type UAV is hereinafter referred to as an “ornithopter”.

[0003] Patent Literature 1 (Japan Patent No. 4,675,346) discloses an example of the ornithopter. This ornithopter includes a main body, and a pair of wings attached to the main body. One of the pair of wings is attached to a left side portion of the main body, and the other of the pair of wings is attached to a right side portion of the main body. Each wing is a single piece wing. The ornithopter floats in the air by a flapping motion of the pair of the single piece wings.

CITATION LIST

Patent Literature

[0004] Patent Literature 1: Japan Patent No. 4,675,346

SUMMARY OF THE INVENTION

[0005] The ornithopter disclosed in Patent Literature 1 uses a single piece wing. In the case of the single piece wing, a wrist portion does not exist. Therefore, there are problems such as degradation of mimetic characteristics, increase of thrust loss and increase of drag.

[0006] An object of the present invention is to provide an ornithopter having high mimetic characteristics, and which can suppress thrust loss and increase of drag.

[0007] In one aspect of the present invention, an ornithopter is provided. The ornithopter includes a main wing mounted on a fuselage, and a control system which controls a flapping motion of the main wing. The main wing includes: an inner spar extending outwardly from the fuselage; an outer spar extending outwardly from the inner spar; and a wrist portion disposed between the inner spar and the outer spar, and which varies a bending angle, which is a relative angle between the inner spar and the outer spar, within a predetermined angle range. The control system includes: an actuator which realizes a raising motion of the inner spar by moving the inner spar in an upward direction and a lowering motion of the inner spar by moving the inner spar in a downward direction; an angle sensor mounted in the wrist portion, and which measures the bending angle; and a control unit which controls the actuator to move the inner spar in response to the measured bending angle of the angle sensor.

[0008] According to the present invention, an ornithopter having high mimetic characteristics and which can suppress thrust loss and increase of drag is realized.

BRIEF DESCRIPTION OF THE DRAWINGS

[0009] FIG. 1 is a plan view of the ornithopter according to some embodiments;

[0010] FIG. 2 is a schematic diagram for indicating a configuration of a main wing of the ornithopter according to some embodiments;

[0011] FIG. 3 is a conceptual diagram for indicating a movable range of an inner spar and an outer spar of the ornithopter according to some embodiments;

[0012] FIG. 4A is a schematic diagram for indicating a configuration of a wrist portion of the ornithopter according to some embodiments;

[0013] FIG. 4B is a schematic diagram for indicating the configuration of the wrist portion of the ornithopter according to some embodiments;

[0014] FIG. 5 is a schematic diagram for indicating a configuration of a main spar and ribs of the ornithopter according to some embodiments;

[0015] FIG. 6 is a schematic diagram for indicating the configuration of the rib of the ornithopter according to some embodiments;

[0016] FIG. 7 is a schematic diagram for indicating a function of the rib of the ornithopter according to some embodiments;

[0017] FIG. 8 is a block diagram for indicating a function and a configuration of a control system of the ornithopter according to some embodiments;

[0018] FIG. 9 is a timing chart for indicating a lowering motion and a raising motion of the main wing of the ornithopter according to some embodiments;

[0019] FIG. 10 is a conceptual diagram for explaining the lowering motion of the main wing of the ornithopter according to some embodiments;

[0020] FIG. 11 is a conceptual diagram for explaining the raising motion of the main wing of the ornithopter according to some embodiments; and

[0021] FIG. 12 is a schematic diagram for indicating an alternative example of some embodiments.

DESCRIPTION OF EMBODIMENTS

[0022] Referring to the drawings, an ornithopter according to some embodiments will be explained.

1. Configuration of Ornithopter

[0023] FIG. 1 is the plan view of the ornithopter 1 according to the present embodiment. Firstly, a coordinate system will be defined. “+ X-direction” corresponds to a traveling direction (direction of flight) of the ornithopter 1, and means a forward direction. On the other hand, “- X-direction” means a rearward direction. “Y-direction” corresponds to a sideward direction of the ornithopter 1, and is perpendicular to the X-direction. “Z-direction” is a direction perpendicular to both the X-direction and the Y-direction. “+ Z-direction” means an upward direction, and “- Z-direction” means a downward direction. Typically, XY-plane corresponds to a horizontal plane, and + Z-direction corresponds to a vertically upward direction.

[0024] As shown in FIG. 1, the ornithopter 1 includes a fuselage 2, a tail wing 3, and a pair of main wings 10. The tail wing 3 is mounted on a rear portion of the fuselage 2. The pair of main wings 10 is mounted on a left side surface of the fuselage 2 and a right side surface of the fuselage 2, respectively. As described later in more detail, a flapping motion of the ornithopter 1 is realized by automatically moving the pair of main wings 10 under control of the control system 100.

[0025] FIG. 2 is the schematic diagram for indicating the configuration of the main wing 10 of the ornithopter 1. In this embodiment, the main wing 10 is not a single piece wing, includes a mimicked wrist portion, and is bendable. More specifically, the main wing 10 has an inner wing portion 11 and an outer wing portion 12. The inner wing portion 11 is a portion of an inner side (a side closer to the fuselage 2) of the main wing 10, and is connected to a shoulder portion of the fuselage 2. On the other hand, the outer wing portion 12 is a portion of an outer side (a side farther from the fuselage 2) of the main wing 10, and is connected to an outer end of the inner wing portion 11.

[0026] The main wing 10 includes a main spar 20 as a frame. The main spar 20 is disposed to extend outwardly (toward a direction away from the fuselage 2) from the shoulder portion of the fuselage 2. More specifically, the main spar 20 has an inner spar 21 and an outer spar 22. The inner spar 21 is a portion, which is provided in the inner wing portion 11, of the main spar 20, and is disposed to extend outwardly from the shoulder portion of the fuselage 2. On the other hand, the outer spar 22 is a portion, which is provided in the outer wing portion 12, of the main spar 20, and is disposed to extend further outwardly than the inner spar 21.

[0027] The main wing 10 further includes a wrist portion 30 disposed between the inner spar 21 and the outer spar 22. That is, the inner spar 21 and the outer spar 22 are connected to each other via the wrist portion 30. The wrist portion 30 is a movable portion, and the main spar 20 is bendable at this wrist portion 30. A configuration example of the wrist portion 30 will be explained later.

[0028] A fuselage-side end portion (a root portion) of the inner spar 21 is connected to an actuator 120 provided on the shoulder portion of the fuselage 2. This actuator 120 moves the inner spar 21 in an upward direction or a downward direction in a rotational and reciprocating manner around the shoulder portion of the fuselage 2 as a center of rotation or around a straight line parallel to the X-axis as a rotation axis. Thereby, a “lowering motion” and a “raising motion” of the inner spar 21 (i.e. the main wing 10) are realized.

[0029] Next, referring to FIG. 3, a movable range of the inner spar 21 and the outer spar 22 will be explained.

[0030] The inner spar 21 rotates around the shoulder portion of the fuselage 2, which is the center of rotation, or around the straight line parallel to the X-axis, which is the rotation axis. Its rotational angle is hereinafter referred to as a “flapping angle θ ”. As the inner spar 21 rotates in the “+ Z-direction” (the upward direction), the flapping angle θ increases. On the other hand, as the inner spar 21 rotates in the “- Z-direction” (the downward direction), the flapping angle θ decreases.

[0031] A variation range RA of the flapping angle θ is predetermined, and an upper limit and a lower limit of the predetermined variation range RA are θ_H and θ_L , respectively. That is, the flapping angle θ varies within the predetermined variation range RA defined by the upper limit angle θ_H and the lower limit angle θ_L . When the flapping angle θ is the upper limit angle θ_H , the inner spar 21 is located at the top position (+ Z-direction side). On the other hand, when the flapping angle θ is the lower limit angle θ_L , the inner spar 21 is located at the bottom position (- Z-direction side).

[0032] It is above mentioned actuator 120 that varies the flapping angle θ of the inner spar 21. The actuator 120 moves the inner spar 21 in the upward direction or in the downward direction in the rotational and reciprocating manner, varies

the flapping angle θ within the predetermined variation range RA. A motion of rotating the inner spar 21 in the downward direction, that is, a motion of decreasing the flapping angle θ toward the lower limit angle θ_L corresponds to the “lowering motion”. On the other hand, a motion of rotating the inner spar 21 in the upward direction, that is, a motion of increasing the flapping angle θ toward the upper limit angle θ_H corresponds to the “raising motion”.

[0033] The outer spar 22 connected to the inner spar 21 via the wrist portion 30 relatively moves with respect to the inner spar 21. The relative angle between the inner spar 21 and the outer spar 22 is hereinafter referred to as a “bending angle ϕ ”.

[0034] Here, in order to facilitate the explanation of the bending angle ϕ , a relative coordinate system in which the inner spar 21 is used as a reference is defined. As shown in FIG. 3, an extending direction of the inner spar 21 corresponds to an S-direction. The S-direction is perpendicular to the X-direction. Also, a T-direction is a direction perpendicular to both the X-direction and the S-direction. + T-direction means an upward direction, and - T-direction means a downward direction.

[0035] The outer spar 22 rotates around the wrist portion 30 as a center of rotation, or around a straight line parallel to the X-axis as the rotation axis. Its rotational angle is above mentioned “bending angle ϕ ”. As the outer spar 22 rotates in the + T-direction (the upward direction), the bending angle ϕ increases. On the other hand, as the outer spar 22 rotates in the - T-direction (the downward direction), the bending angle ϕ decreases.

[0036] A variation range RB of the bending angle ϕ is predetermined, and an upper limit and a lower limit of the predetermined variation range RB are ϕ_H and ϕ_L , respectively. That is, the bending angle ϕ varies within the predetermined variation range RB defined by the upper limit angle ϕ_H and the lower limit angle ϕ_L . When the bending angle ϕ is the upper limit angle ϕ_H , the outer spar 22 is located at the top position (+ T-direction side). Typically, when the bending angle ϕ is the upper limit angle ϕ_H , the inner spar 21 and the outer spar 22 are forming a straight line. That is, an extending direction of the outer spar 22 coincides with the S-direction. However, embodiments are not limited to above mentioned example. On the other hand, when the bending angle ϕ is the lower limit angle ϕ_L , the outer spar 22 is located at the bottom position (- T-direction side).

[0037] In the present embodiment, unlike the case of the inner spar 21 described above, an actuator is not provided with respect to the outer spar 22. That is, in the wrist portion 30, the actuator for directly and mechanically moving the outer spar 22 is not provided. As will be explained later in detail, the outer spar 22 follows the lowering motion and the raising motion of the inner spar 21, and is moved only in a “passive” manner.

[0038] The wrist portion 30 is configured such that the bending angle ϕ of the outer spar 22 varies within the predetermined variable range RB. FIG. 4A and FIG. 4B schematically indicate a configuration example of such a wrist portion 30. FIG. 4A is an SX-cross-sectional view taken along the line A-A' in FIG. 4B, and FIG. 4B is an ST-cross-sectional view taken along the line B-B' in FIG. 4A.

[0039] As shown in FIG. 4A and FIG. 4B, in the wrist portion 30, a connector 31 connected to an end portion of the inner spar 21 is provided. Also, on an end portion of the outer spar 22, a shaft 32 which can move integrally with the outer spar 22 is provided. The shaft 32 is fitted in a hole formed in

the connector **31**. Thereby, the outer spar **22** can rotate around the shaft **32**. That is, the bending angle ϕ of the outer spar **22** becomes variable. The upper limit angle ϕ_H and the lower limit angle ϕ_L of the bending angle ϕ can be set appropriately by adjusting a shape of the connector as shown in FIG. 4B. In other words, the variation range RB of the bending angle ϕ is appropriately set by a mechanical limiter. For example, a position where an upper surface of the outer spar **22** is contact with a lower surface of an upper portion of the connector **31** corresponds to the upper limit angle ϕ_H , and a position where a lower surface of the outer spar **22** is contact with an end surface of a lower portion of the connector **31** corresponds to the lower limit angle ϕ_L .

[0040] Further, in the wrist portion **30**, an angle sensor **130** for measuring the bending angle ϕ is provided. In the example shown in FIG. 4A and FIG. 4B, a gear **33** is provided on one end of the shaft **32**, and is configured to rotate with the rotation of the outer spar **22**. The angle sensor **130** is disposed on the connector **31** so as to be adjacent to the gear **33**, and measures the bending angle ϕ of the outer spar **22** based on the rotation of the gear **33**. As explained later in detail, according to the present embodiment, the bending angle ϕ measured by the angle sensor **130** is used to control a motion of the inner spar **21**.

[0041] Next, referring to FIGS. 5 to 7, a rib, which is another frame of the main wing **10**, will be explained. As shown in FIG. 5, on the main spar **20**, a plurality of the ribs **25** is mounted. Each rib **25** is provided so as to extend rearwardly ($-X$ -direction) from the main spar **20**.

[0042] FIG. 6 indicates a configuration of one rib **25**. A front side portion of the rib **25** ($+X$ -direction side) is a rib front portion **25F**. On the other hand, a rear side portion of the rib **25** ($-X$ -direction side) is a rib rear portion **25R**. As shown in FIG. 6, a hole **26** is formed in the rib front portion **25F**, and the main spar **20** passes through the hole **26**. That is, the rib **25** is disposed rotatably about the main spar **20**.

[0043] In addition, in the present embodiment, the rib **25** has an S-shaped camber (an inverted camber). The rib rear portion **25R** is curved upward. Referring to FIG. 7, a function of this S-shaped camber wing will be explained. During the lowering motion of the main wing **10**, the rib **25** having the S-shaped camber is automatically tilted (twisted) from the X -direction as shown in FIG. 7. This tilt angle (twist amount) is determined based on a flight speed of the ornithopter **1** and a lowering speed of the main wing **10** at the position of the ornithopter **1**, and the tilt angle becomes larger as the lowering speed becomes higher. That is, during the lowering motion of the main wing **10**, a wing plane L of the main wing **10** (for simplicity, the wing plane is represented linearly) is automatically inclined at some angle from the X -direction. Then, since the wing plane L is inclined from the X -direction, a thrust in the $+X$ -direction (traveling direction) is generated as shown in FIG. 7. That is, the wing plane L is automatically inclined such that the wing plane L becomes stable against the wind vane direction, and consequently the thrust is generated.

[0044] Note that, in the present embodiment, an actuator is not provided for the rib **25**. In other words, an actuator for directly and mechanically moving the rib **25** is not provided. As described above, the rib **25** has the S-shaped camber, and is automatically tilted (twisted) from the X -direction during the lowering motion of the main wing **10**.

2. Control System

[0045] The ornithopter **1** according to the present embodiment has a control system **100** for controlling a flapping motion of the main wing **10**. FIG. 8 is the block diagram for indicating a function and a configuration of the control system **100**. The control system **100** includes a control unit **110**, the actuator **120**, the angle sensor **130**, and an angle sensor **140**.

[0046] As described above, the actuator **120** is a mechanical mechanism for moving the inner spar **21**. The actuator **120** rotates the inner spar **21** in the upward direction or the downward direction, and thereby the raising motion or the lowering motion is realized.

[0047] As described above, the angle sensor **130** is provided in the wrist portion **30**, and measures the bending angle ϕ of the outer spar **22**. Then, the angle sensor **130** transmits bending angle data DB indicating the measured bending angle ϕ to the control unit **110** in a real-time manner.

[0048] The angle sensor **140** is provided with the actuator **120**, and measures the flapping angle ϕ of the inner spar **21**. Then, the angle sensor **140** transmits flapping angle data DA indicating the measured flapping angle ϕ to the control unit **110** in a real-time manner. Note that the angle sensor **140** is not necessarily required.

[0049] The control unit **110** is a computer that is mounted inside the fuselage **2**. The control unit **110** controls the raising motion and the lowering motion of the inner spar **21** by controlling the actuator **120**. More specifically, the control unit **110** receives the flapping angle data DA and the bending angle data DB, and monitors the flapping angle ϕ and the bending angle ϕ in a real-time manner. Then, the control unit **110** controls the actuator **120** and moves the inner spar **21** in response to at least the bending angle ϕ . A controlled object by the control unit **110** is, for example, a timing of the raising motion and the lowering motion.

3. Example of Control

[0050] Next, an example of control for the lowering motion and the raising motion will be explained. FIG. 9 is the timing chart for indicating the example of the control. In FIG. 9, transition of the flapping angle θ of the inner spar **21** and transition of the bending angle ϕ of the outer spar **22**, respectively are indicated. In addition, states S1 to S5 correspond to the lowering motion, and states S6 to S10 correspond to the raising motion. In the following, the lowering motion (states S1 to S5) and the raising motion (states S6 to S10), respectively will be explained in detail.

3-1. Lowering Motion

[0051] FIG. 10 is the conceptual diagram for explaining the lowering motion. Referring to FIG. 9 and FIG. 10, the lowering motion will be explained.

<State S1>

[0052] The state S1 is a state in which both the inner spar **21** and the outer spar **22** are at the top position. In this moment, the flapping angle θ is the upper limit angle θ_H , and the bending angle ϕ is the upper limit angle ϕ_H . In this state S1, the lowering motion is started. Specifically, the control unit **110** controls the actuator **120** to initiate the lowering motion of the inner spar **21**.

<State S2>

[0053] The state S2 is a state in which the inner spar **21** is being lowered by the actuator **120**. In this moment, the flapping angle θ is an intermediate angle θ_M ($\theta_H > \theta_M > \theta_L$). The outer spar **22** is passively moved in the downward direction by following the lowering motion of the inner spar **21**, while the bending angle ϕ is remained in the upper limit angle ϕ_H .

[0054] Further, as explained with reference to FIG. 7, the rib **25** having the S-shaped camber is automatically tilted (twisted) from the X-direction. That is, the wing plane L of the wing **10** is automatically inclined at some angle from the X-direction. Thereby, the thrust in the + X-direction (traveling direction) is generated. Note that the tilt angle (twist amount) is determined based on the flight speed of the ornithopter **1** and the lowering speed of the main wing **10** at the position of the ornithopter **1**, and the tilt angle becomes larger as the lowering speed becomes higher. Therefore, the tilt angle as well as the resultant thrust is progressively increasing toward the wing tip (as farther from the fuselage **2**).

<State S3>

[0055] The state S3 is a state in which the inner spar **21** is at the bottom position. In this moment, the flapping angle θ is the lower limit angle θ_L . The motion of the inner spar **21** is stopped in this moment, while the outer spar **22**, which was following the inner spar **21**, continues to move by the inertia. That is, the outer spar **22** naturally moves by the momentum of the lowering motion of the inner spar **21** even if the actuator is not provided with the outer spar.

<State S4>

[0056] The state S4 is a state in which only the outer spar **22** moves, while the inner spar **21** is at the bottom position. In this moment, the bending angle ϕ is an intermediate angle ϕ_M ($\phi_H > \phi_M > \phi_L$). Note that, in this moment, the actuator **120** fixes the inner spar **21**, and keeps the flapping angle θ at the lower limit angle θ_L .

<State S5>

[0057] The state S5 is a state in which both the inner spar **21** and the outer spar **22** are at the bottom position. In this moment, the flapping angle θ is the lower limit angle θ_L , and the bending angle ϕ is the lower limit angle ϕ_L . When the control unit **110**, which monitors the flapping angle θ and the bending angle ϕ in the real-time manner using the angle sensors **130** and **140**, detects this state S5, subsequent raising control (see state S6) is initiated. That is, when the state in which the bending angle ϕ becomes the lower limit angle θ_L is detected after the lowering motion of the inner spar **21**, the control unit **110** controls the actuator **120** to initiate the raising motion of the inner spar **21**.

3-2. Raising Motion

[0058] FIG. 11 is the conceptual diagram for explaining the raising motion. Referring to FIG. 9 and FIG. 11, the raising motion will be explained.

<State S6>

[0059] The state S6 is the same as the above mentioned state S5. In this state S6, the fixation of the inner spar **21** is

released, and the raising motion is initiated. Specifically, the control unit **110** controls the actuator **120** to start the raising motion of the inner spar **21**.

<State S7>

[0060] The state S7 is a state in which the inner spar **21** is being raised by the actuator **120**. In this moment, the flapping angle θ is an intermediate angle θ_M ($\theta_H > \theta_M > \theta_L$). The outer spar **22** is passively moved in the upward direction by following the raising motion of the inner spar **21**, while the bending angle ϕ is remained in the lower limit angle ϕ_L .

<State S8>

[0061] The state S8 is a state in which the inner spar **21** is at the top position. In this moment, the flapping angle θ is the upper limit angle θ_H . The motion of the inner spar **21** is stopped in this moment, while the outer spar **22**, which was following the inner spar **21**, continues to move by the inertia. That is, the outer spar **22** naturally moves by the momentum of the raising motion of the inner spar **21** even if the actuator is not provided with the outer spar.

<State S9>

[0062] The state S9 is a state in which only the outer spar **22** moves, while the inner spar **21** is at the top position. In this moment, the bending angle ϕ is an intermediate angle ϕ_M ($\phi_H > \phi_M > \phi_L$). Note that, in this moment, the actuator **120** fixes the inner spar **21**, and keeps the flapping angle θ at the upper limit angle θ_H .

<State S10>

[0063] The state S10 is a state in which both the inner spar **21** and the outer spar **22** are at the top position. In this moment, the flapping angle θ is the upper limit angle θ_H , and the bending angle ϕ is the upper limit angle ϕ_H . When the control unit **110**, which monitors the flapping angle θ and the bending angle ϕ in the real-time manner using the angle sensors **130** and **140**, detects this state S10, above mentioned lowering control (see state S1) is initiated. That is, when the state in which the bending angle ϕ becomes the upper limit angle ϕ_H is detected after the raising motion of the inner spar **21**, the control unit **110** controls the actuator **120** to initiate the lowering motion of the inner spar **21**.

[0064] Note that in the raising motion, there exists a possibility that the main wing **10** is automatically raised by aerodynamic force. In such a case, it is not necessary to actively move the inner spar **21** using the actuator **120**. In this case, in the state S6, the control unit **110** controls the actuator **120** to only release the fixation of the inner spar **21**.

[0065] By repeating the lowering motion and the raising motion described above, the flapping motion of the ornithopter **1** according to the present embodiment is realized.

4. Effect

[0066] According to the present embodiment, the main wing **10** of ornithopter **1** includes the mimicked wrist portion **30** configured to be bendable. Therefore, mimetic characteristics are improved and the thrust loss and the increase of the drag are suppressed as compared to the case in which the single piece wing is used.

[0067] Furthermore, according to the present embodiment, the following effects can be obtained. To illustrate the effects, firstly, following comparative example will be considered.

[0068] In the comparative example, in the wrist portion 30, an actuator (motor, link mechanism etc.) for directly and mechanically moving the outer spar 22 is provided. Then, in addition to the inner spar 21, the outer spar 22 is forcibly moved using the actuator. Furthermore, an actuator is also provided for the rib 25, and by forcibly inclining the rib 25, the wing plane L is tilted from the X-direction. Motion states (motion timing, motion frequency, motion speed) of the inner spar 21, the outer spar 22 and the rib 25 using the actuators are appropriately set, respectively.

[0069] In the case of such a comparative example, the following problems exist. Firstly, since extra actuators and wiring are necessary, weight will be increased and constitution will be complicated. Moreover, since the way of forcibly moving the outer spar 22 or the rib 25 is different from a mechanism in a natural bird, the mimetic characteristics are deteriorated.

[0070] In addition, in case that the lowering motion is initiated before the outer spar 22 reaches the top position (before the bending angle ϕ becomes the upper limit angle ϕH) or the raising motion is initiated before the outer spar 22 reaches the bottom position (before the bending angle ϕ becomes the lower limit angle ϕL), problems such as thrust loss, drag increase and deterioration of mimetic characteristics occur. In order to prevent such problems, motions of the inner spar 21, the outer spar 22 and the rib 25, respectively should be appropriately controlled. However, appropriate motion states (motion timing, motion frequency, motion speed) vary greatly depending on the environment such as flight speed etc. Therefore, it is necessary that the motion states of the inner spar 21, the outer spar 22 and the rib 25, respectively are controlled dynamically in response to the variation of the environment such as flight speed. However, such a dynamical control is very difficult. That is, the comparative example has poor adaptability to the environment.

[0071] On the contrary to such a comparative example, in the present embodiment, the actuator for directly and mechanically moving the outer spar 22 is not provided in the wrist portion 30. The outer spar 22 only passively moves by following the lowering motion and the raising motion of the inner spar 21. As explained with reference to FIG. 10 and FIG. 11, the outer spar 22, which follows the inner spar 21, naturally moves by the momentum of the raising motion or the lowering motion of the inner spar 21 without the actuator.

[0072] Further, the actuator is not provided with respect to the rib 25. That is, the actuator for directly and mechanically moving the rib 25 is not provided. As explained with reference to FIG. 6 and FIG. 7, the rib 25 has the S-shaped camber form, and is automatically tilted from the X-direction during the lowering motion of the main wing 10.

[0073] Thus, since it is not necessary to provide extra actuators with respect to the outer spar 22 or the rib 25, it is possible to reduce the weight and simplify the mechanism. In addition, since the outer spar 22 or the rib 25 is not forcibly moved, the mimetic characteristics are improved and the thrust loss and the increase of the drag are suppressed.

[0074] Furthermore, according to the present embodiment, the angle sensor 130 for measuring the bending angle ϕ of the outer spar 22 is provided in the wrist portion 30. Then, the control unit 110 controls the actuator 120 to move the inner spar 21 in response to the measured bending angle ϕ by the

angle sensor 130. As a result, as shown in FIGS. 9 to 11, it is possible that the lowering motion is initiated after the outer spar 22 reaches the top position (after the bending angle ϕ becomes the upper limit angle ϕH). Also, it is possible that the raising motion is initiated after the outer spar 22 reaches the bottom position (after the bending angle ϕ becomes the lower limit angle ϕL). That is, it is possible to realize the optimum flapping motion from the viewpoint of the thrust, the drag, and the mimetic characteristics. Since the bending angle ϕ itself is monitored using the angle sensor 130, the optimum flapping motion is always realized regardless of the environment such as the flight speed. In this sense, the present embodiment can be said to have a high adaptability to the environment.

5. Alternative Example

5-1. First Alternative Example

[0075] As described above, according to the present embodiment, the outer spar 22 passively moves by following the lowering motion and the raising motion of the inner spar 21. However, there exists a possibility that, the motion of the outer spar 22 becomes a jittery motion in case of using the above mentioned configuration itself. Therefore, as shown in FIG. 12, a cushioning member 40 may be provided in the wrist portion 30. The cushioning member 40 serves to mitigate momentum of relative motion of the outer spar 22 with respect to the inner spar 21. For example, the cushioning member 40 is a spring connecting between the outer spar 22 and a support member. With such a cushioning member 40, it is possible to suppress a sudden movement of the outer spar 22. As a result, the mimetic characteristics of the ornithopter 1 are further improved.

5-2. Second Alternative Example

[0076] In the example of control explained with reference to FIGS. 9 to 11, the actuator 120 is activated to move the inner spar 21 by using the detection of $\phi = \phi H$ or $\phi = \phi L$ as a trigger. However, a reference value of the bending angle ϕ which is served as the trigger may not necessarily be the upper limit angle ϕH or the lower limit angle ϕL . The reference value of the bending angle ϕ which is served as the trigger may be appropriately set based on a motion mode of the ornithopter 1 or an intended purpose.

[0077] As described above, some embodiments of the present invention has been explained with reference to the accompanying drawings. However, the present invention is not limited to the above mentioned embodiments, and may be appropriately modified by the person having ordinary skill in the art without departing from the scope of the invention.

[0078] It should be noted that this application claims a priority based on Japan Patent Application No. JP 2013-032544 filed on Feb. 21, 2013 and the disclosure thereof is incorporated herein by reference.

1. An ornithopter comprising:

- a main wing mounted on a fuselage; and
- a control system configured to control a flapping motion of the main wing,

wherein the main wing comprises:

- an inner spar extending outwardly from the fuselage;
- an outer spar extending outwardly from the inner spar; and
- a wrist portion disposed between the inner spar and the outer spar, and configured to vary a bending angle within

a predetermined angle range, the bending angle being a relative angle between the inner spar and the outer spar, wherein the control system comprises:

an actuator configured to perform a raising motion of the inner spar by moving the inner spar in an upward direction and to perform a lowering motion of the inner spar by moving the inner spar in a downward direction;

an angle sensor mounted in the wrist portion, and configured to measure the bending angle; and

a control unit configured to control the actuator to move the inner spar in response to the measured bending angle of the angle sensor.

2. The ornithopter according to claim 1, wherein the bending angle in a state in which the outer spar is located at a top position within the predetermined angle range is defined as an upper limit angle,

wherein the control unit is configured to start the lowering motion of the inner spar by controlling the actuator when a state in which the bending angle reaches the upper limit angle is detected after the raising motion of the inner spar.

3. The ornithopter according to claim 1, wherein the bending angle in a state in which the outer spar is located at a bottom position within the predetermined angle range is defined as a lower limit angle,

wherein the control unit is configured to start the raising motion of the inner spar by controlling the actuator when a state in which the bending angle reaches the lower limit angle is detected after the lowering motion of the inner spar.

4. The ornithopter according to claim 1, wherein an actuator which directly and mechanically moves the outer spar is not provided.

5. The ornithopter according to claim 1, further comprising:

a cushioning member mounded in the wrist portion, and configured to mitigate momentum of relative movement of the outer spar with respect to the inner spar.

6. The ornithopter according to claim 1, wherein the main wing comprises a main spar including said inner spar and said outer spar,

wherein the main wing further comprises a rib extending rearwardly from the main spar, and

wherein the rib has an S-shaped camber.

7. The ornithopter according to claim 6, wherein an actuator which directly and mechanically moves the rib is not provided.

* * * * *