

J. RITTY & J. BIRCH.

CASH REGISTER AND INDICATOR.

No. 271,363.

Patented Jan. 30, 1883.

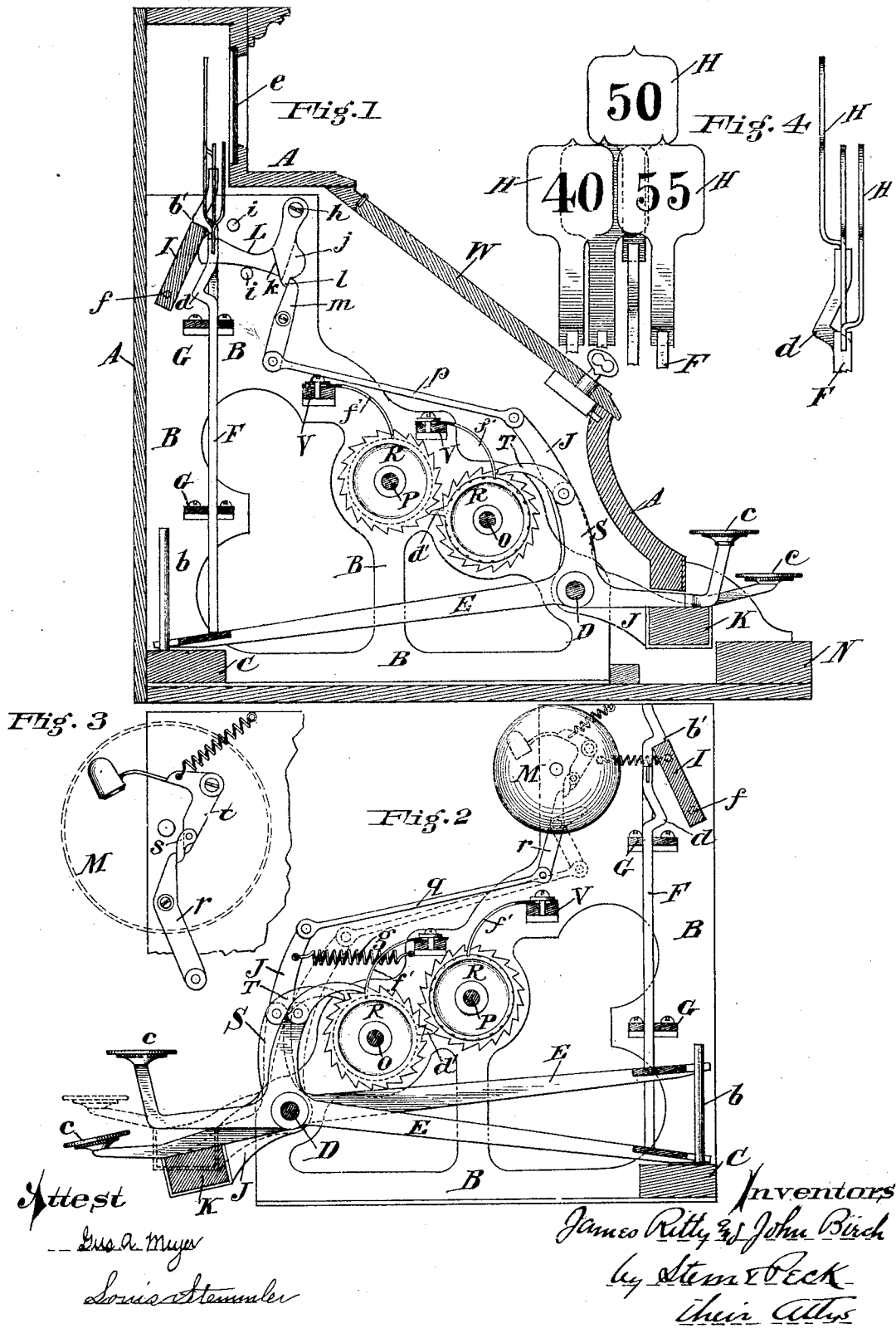

J. RITTY & J. BIRCH.  
CASH REGISTER AND INDICATOR.

No. 271,363.

Patented Jan. 30, 1883.

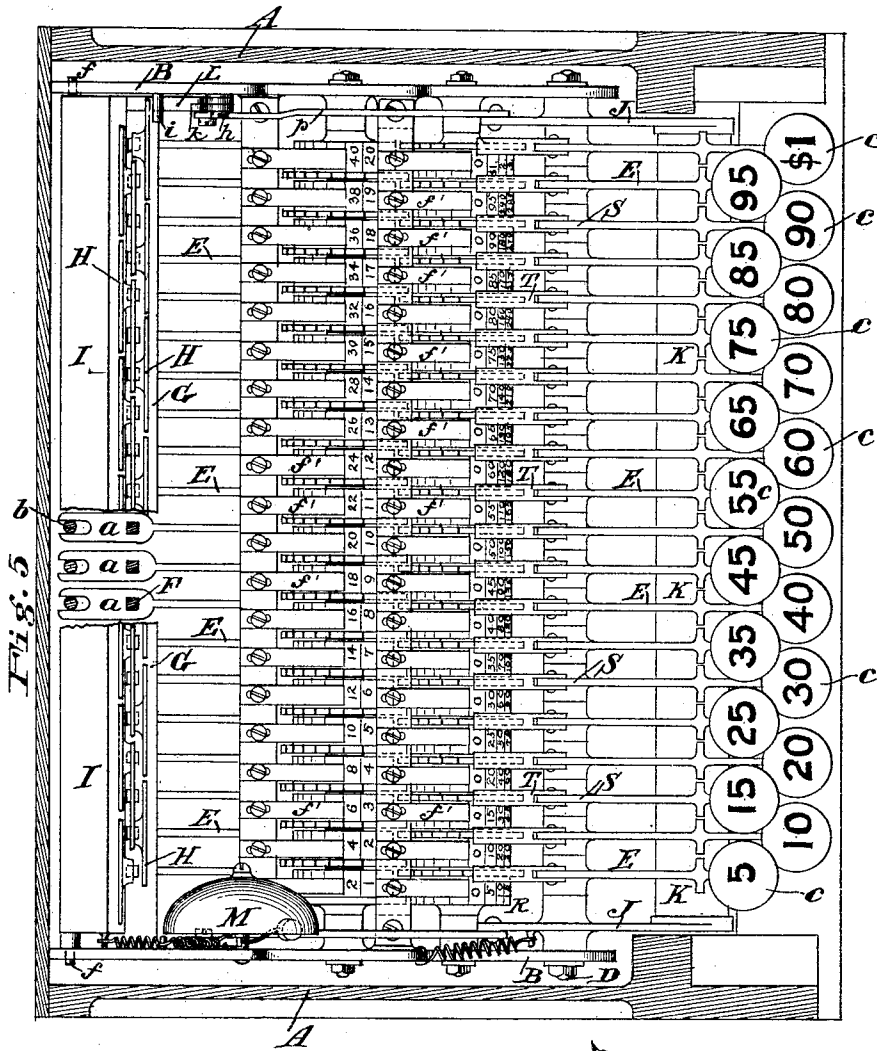

FIG. 5

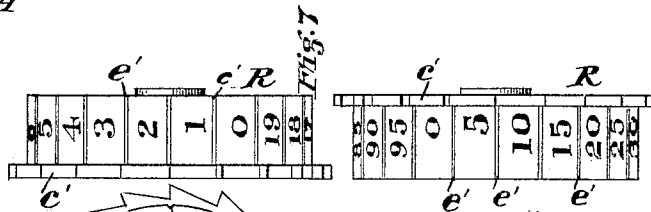
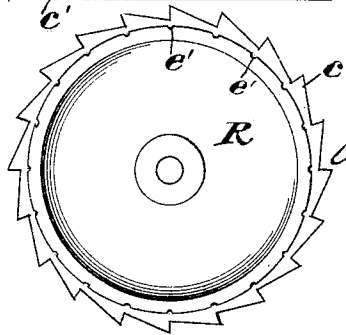

Fig. 7

Attest

*Geo. A. Meyer*  
*Louis A. Tomules*

Fig. 6



Inventors  
*James Ritty & John Birch*  
by *Stearns & Peck*  
*Chas. Atty*

# UNITED STATES PATENT OFFICE.

JAMES RITTY AND JOHN BIRCH, OF DAYTON, ASSIGNORS TO JACOB H. ECKERT, OF CINCINNATI, OHIO.

## CASH REGISTER AND INDICATOR.

SPECIFICATION forming part of Letters Patent No. 271,363, dated January 30, 1883.

Application filed February 15, 1882. (No model.)

*To all whom it may concern:*

Be it known that we, JAMES RITTY and JOHN BIRCH, both citizens of the United States, and residing at Dayton, Montgomery county, Ohio, have invented certain new and useful Improvements in Cash Registers and Indicators, of which the following is a full, clear, and exact description.

Our invention relates to an improvement in cash registers and indicators designed for the use of store-keepers and others as a means of accurately registering the total cash receipts for any given period of time—as a day, for instance—and for indicating to the customers that the amount paid has been registered by disclosing to their view such amounts upon figured tablets.

The arrangement of the parts and operation of the machine are such that no tablet can be exhibited without its value being counted upon the registering mechanism, and whenever any tablet is disclosed it remains so until the machine is operated to disclose a second tablet.

The novelty of our invention consists in the construction, combinations, and arrangements of the various parts, as will be herewith set forth and specifically claimed.

In the accompanying drawings, Figure 1, Sheet 1, is a sectional side elevation of our improved machine, looking toward its right-hand end. Fig. 2, Sheet 1, is a corresponding view, looking toward the left-hand end of the machine. Fig. 3, Sheet 1, is an enlarged view of the bell, operating-trip, and hammer. Fig. 4, Sheet 1, is a front and side elevation of a group of indicating-tablets. Fig. 5, Sheet 2, is a plan view of the entire mechanism. Fig. 6, Sheet 2, is a side elevation of one of the registering-disks. Fig. 7, Sheet 2, are plan views of a pair of registering-disks.

We provide any suitable box or case, A, ornamented as desired, and of the general shape indicated, though its shape and ornamentation may be varied infinitely. In this outer case is fitted a metal frame-work, consisting chiefly of two upright sides, B, united by a cross-bar, C, and by the shafts and bars which support the operating mechanism.

In the lower portion of the frame, and ex-

tending horizontally across it, is a rod or shaft, D, supported by and aiding to connect the sides B of the frame. Upon this shaft are hung a series of parallel keys, E, of metal, made heavier in the rear, so as to remain in and return to the position indicated in Fig. 1 by their gravity alone, without the use of springs or other devices. In the present instance twenty of these keys are shown, though any number may be employed. Each key has upon its front end, which extends through and projects from an opening in the front of the case or frame, a button, e, having marked upon it a figure to correspond with the value intended to be indicated and registered whenever that key is operated by depressing the button. In a machine with twenty keys the first button to the left would be numbered 5, the second 10, and the third 15, to represent five, ten, and fifteen cents, and so on progressively. As these buttons are about three-quarters of an inch in diameter, it would make the machine unnecessarily wide to arrange the whole series side by side in one bank; so we have arranged them in two banks, the one above the other, as clearly seen in Figs. 1, 2, and 5. As seen at a in Fig. 5, Sheet 2, the rear end of each key is flattened and slotted at its outer end, so as to embrace vertical guide-pins b, set in the bar C, and which aid the shaft D in preventing lateral play or twist of the keys.

Resting upon the flattened ends of the keys are vertical metal rods F—one for each key—which pass and have vertical play through perforations in metal guide-bars G, extending across and supported by the sides B. These rods may be any shape in cross-section, though we prefer to make them square, with square perforations in the guide-bars G. The upper portion of each rod, just above the upper bar, G, is bent to form a knuckle or shoulder, d, upon its rear side, which has beveled or inclined operating-faces, for a purpose to be presently explained.

Suitably secured to the top of each rod is a tablet, H, of thin flat metal, and upon the face of each tablet is a number corresponding with the number upon the key over whose rear end the rod of that tablet rests. Thus the tablet of

the rod resting upon the key whose button is marked 5 is likewise marked 5, and so on through the series. In order to get the tablets into as narrow a space as possible, and thus not make the machine wider than necessary, their stems are bent so that the tablets can overlap each other, as shown in Fig. 4, and yet each can be operated without interfering with another.

10 In the upper portion of the case is a large horizontal opening extending across the front of the case and covered with transparent glass *e*, Fig. 1, and when the keys are in their normal position of rest, with the rods *F* resting upon their rear ends, all of the tablets are hidden from view below the lower edge of the opening *e*; but when any key is pressed down by means of its button the rod of that key is raised and its tablet exposed to view through the glass *e*.

20 In Figs. 1 and 4 one of the tablets is thus shown raised up and exposed to view. Now, it is an important feature of our machine that after a key has been operated and its tablet exposed to view such tablet shall remain up and exposed until another key is operated, whereupon the first falls back out of view and the second remains exposed, and so on, thus always keeping in view the tablet of the key last operated. To effect this result we pivot, by means of trunnions or a shaft extending between the sides *B*, a forwardly-inclined wing, *I*, pivoted at its lower edge, as at *f*, and resting at its upper edge against the rear sides of the upper portions of the rods *F*. This wing extends back of all of the rods, and is free to vibrate on its pivotal axis *f*. It is yieldingly held against the rods by any suitable spring, a spiral spring being shown for that purpose in Fig. 2, secured at one end of the wing and to the side *B* of the frame. Just on the inner sides of the frames *B*, and pivoted upon the shaft *D*, are flat arms *J*, extending upward and rearward and downward and forward of their pivotal points. The front ends of these arms extend into the opening made for the keys in the front of the case *A*, and are connected by a bar, *K*, extending entirely across this opening and resting up against the under sides of all the keys. Of course when any one of the keys is depressed the bar *K* is likewise carried down, and the upper portions of the arms *J* are vibrated forward, as seen in Fig. 2, where the dotted lines represent the normal position of the arms and one of the lower bank of keys, and the unbroken lines show the key depressed, carrying down the bar *K* and drawing forward the arms *J*. To return the bar *J* when the key is released, and to assist the key itself to return, any suitable spring may be employed. We have shown one, *g*, Fig. 2, connected at one end to one of the arms *J* and at its other end to the side of the frame *B*.

Pivoted at *h* upon the right-hand side of the frame *B*, Fig. 1, is a bell-crank tripping-arm, *L*, with the rear end rounded and rest-

ing against the upper portion of the front side of the wing *I*. Its vibration is limited by two pins or detents, *i*, as shown, and upon the same pivot, *h*, is hung a follower, *j*, whose lower end extends below the elbow of the bell-crank, and whose rear edge rests against a shoulder, *k*, upon the bell-crank. The lower end of this follower has a beveled engaging-nose, *l*, against which the upper end of a trigger, *m*, pivoted at or near its middle, as at *o*, to the side *B* rests. The lower end of this trigger is connected to the upper end of the arm *J* on that side of the machine by a link, *p*. The opposite arm *J*, Figs. 2 and 3, is connected by a similar link, *q*, to similar tripping mechanism, *r s t*, for operating the hammer *u* of a bell or gong, *M*, which is secured in any suitable manner to the side *B* of the frame.

Now, the operation of thus much of the machine is as follows: When any key is pressed down its rod and tablet are raised, and the elbow *d* of the rod, in rising, aids in pressing back the wing *I*; but to aid the elbow the arm *J* on the right, which, as before explained, is drawn forward whenever a key is pressed, imparts motion to the link *p* and trigger *m*, whose upper end, acting on the nose *l* of the follower *j*, presses it back, and with it the bell-crank *L*, which is thus forced against the wing and presses it back. Now, the parts are so arranged that when the lower side of the elbow *d* is just above the top edge of the wing the key has completed its downward stroke, and is arrested by the front bar, *N*, of the case, the trigger *m* has passed beyond the nose *l* of the bell-crank, so that the latter swings back out of the way, and the spring *a'* draws the wing forward under the elbow *d*, so that the latter rests upon the upper edge, as seen at *b'*, Figs. 1 and 2, and there remains, thus retaining the tablet and rod of the operated key elevated. Now, upon releasing the key it falls backward to its normal position by gravity, and is aided by the spring *g*, Fig. 2, which returns the bar *K* and arms *J*. The follower *j*, being free to swing forward without moving the bell-crank, permits the trigger *m* to flip it up and pass under its nose to its normal position. During this operation the opposite arm *J*, Fig. 2, has in like manner actuated the hammer of the gong, which is sounded every time a key is depressed to its farthest limit, and only then, and thus gives notice to the customer that the machine has been properly operated. Whenever the same key is successively operated its rod and the tablet remain up and exposed to view; but when a different key is operated the tablet of the previous one is released and falls back out of sight, and the tablet of the operated key remains up and exposed.

The above constitutes the indicating mechanism, and we will now proceed to describe the registering or recording mechanism.

Upon two parallel transverse shafts, *O* and *P*, having their ends secured in the sides *B*,

and aiding to support the same, are strung a series of disks or wheels, R, Figs. 6 and 7. Those on each shaft about the one against the other, but are loose upon the shafts, so as to revolve thereon. These wheels are in pairs, one over each key of the machine—that is to say, there are two wheels over each key, one on the shaft P and one on the shaft O, the two being in line and with their peripheries close to each other. The wheels on the shaft P we will designate as “dollar-wheels” and those on the shaft O as “cent-wheels.” Each wheel has at one side a ratchet, *c'*, projecting slightly above the periphery, and having twenty teeth. The ratchets on the cent-wheels are all on one side—say the right-hand side thereof—while those on the dollar-wheels are all on the opposite or left-hand side. This arrangement is effected so as to bring the two sets of wheels close together.

Upon each of the cent-wheels there is a radially-projecting pin or stud, *d'*, Figs. 1 and 2, secured in any suitable manner, and arranged in line with the ratchets on the dollar-wheels, so that on every complete revolution of the cent-wheels this pin comes in contact with one of the teeth of the ratchets on the dollar-wheels and revolves them one notch, or a twentieth of a revolution.

Projecting up from each key, just above or in front of its pivotal point, is an arm, S, to the upper end of which is pivoted a dog, T, whose nose engages with the ratchets of its corresponding cent-wheel, as clearly seen in Figs. 1 and 2. Now, as any key is depressed its arm S is drawn back, carrying with it its dog, and the length and proportion of the parts are such that a full stroke of the key only draws its dog back sufficiently to pass one tooth of the ratchet, and no more. This motion does not disturb the wheel; but as the key falls back after being released the dog is pushed forward and turns the cent-wheel one-twentieth of a revolution, and thus through the whole series of keys. Each wheel of both sets is divided into twenty equal transverse divisions on its periphery, and these are separated by shallow gutters *e'*.

Upon transverse bars V, extending between the sides B, and arranged over and slightly back of each set of wheels, are adjustably secured by set-screws curved flat springs *f'*, whose lower ends rest in the before-mentioned gutters *e'*. These springs form brakes for the wheels and prevent their being turned more than one notch at each operation of the keys.

The manner in which a record is kept of the operations of the keys is as follows: Commencing with the dollar and cent wheels over the five-cent key, we mark the first division of the cent-wheel 0, the next 5, the next 10, and so on up to 95, as seen clearly in Fig. 7. On the dollar-wheel the first division is 0, the next 1, 2, and so on up to 19. Of the wheels over the ten-cent key, the cent-wheel is marked in a series of 0, 10, 20, and so on progressively,

and the dollar-wheel is marked in a series of 0, 2, 4, 6, and so on progressively. Of the wheels over the fifteen-cent key, the cent-wheel is marked in a series increasing by three, and so on through the whole set.

To keep a register of the machine, all the wheels are first set with their zeros just in front of the brakes at the commencement of the day's work, and each key keeps an independent register of the number of its operations, so that at the end of the day's work the proprietor, on opening the case, can read off the wheels the totals of their operation. For instance, the five-cent key will show a register of twelve dollars and fifty cents on its two wheels, the ten-cent key will show a register of twenty dollars and forty cents, the fifteen-cent key a register of eighteen dollars and forty-five cents, and so on, the readings being taken from the numbers exposed just in front of the brakes. He jots down these different sums and adds them up, and so ascertains exactly the amount of cash that should be in the till. For very large establishments doing a very large business it might be desirable to have a third bank of wheels arranged behind the dollar-wheels and connected to them in the same manner as the other two banks, so that one entire revolution of a wheel of the second bank would turn the corresponding wheel of the third bank one notch. In such case the numbers on the third bank would be a progressive series of the highest number on the second bank—that is to say, taking the five-cent key as an example, its third wheel would be numbered 0, 20, 40, and so on.

As before stated, any suitable case to inclose the mechanism may be employed, and it should have a lid or cover, W, Fig. 1, securely locked, so that no one but the proprietor could open it to expose the registering-wheels; and the only exposed parts of the mechanism while the machine is in use are the operating ends of the keys and the tablets, which can be plainly seen through the glass of the opening in the top of the case.

Having thus fully described our invention, we claim—

1. In a registering and indicating machine, the combination, with a series of indicating-tablets operated by a series of keys, of a series of rods, each provided with a detent or shoulder and carrying one of the aforesaid tablets, and a supporting-wing with connecting mechanism, whereby upon operating any one of the keys the wing is so moved as to permit the passage of the rod, and whereby upon the release of the key the wing engages with and holds up the tablet-rod and tablet, substantially as described.

2. The keys E, pivoted upon a shaft, D, and provided with upwardly-extending arms S, carrying dogs T, in combination with the registering ratchet-wheels R, substantially as described.

3. The vertical tablet-rods F, arranged in

guides, and having knuckles or elbows *d*, in combination with the keys E and wing I, substantially as described.

3 4. The wing I, in combination with the trip L, trigger *m*, link *p*, and arm J, substantially as and for the purpose specified.

5. The combination, with the bell M and trip *r*, with connecting mechanism, of the arms J, pivoted upon the shaft D, supported by the

spring *g*, and connected by the bar K, arranged beneath the keys E, substantially as described, for the purpose specified.

JAMES RITTY.  
JOHN BIRCH.

Witnesses:

F. DOEBLING,  
B. W. EARLY.