



US006213778B1

(12) **United States Patent**
Cohen

(10) **Patent No.:** **US 6,213,778 B1**
(45) **Date of Patent:** **Apr. 10, 2001**

(54) **PAINTING KIT AND RELATED METHOD**

5,772,274 6/1998 Legrand
6,022,219 * 2/2000 Cohen 434/84

(76) **Inventor:** **Elise Cohen**, 814 W. Bleeker, Unit C-3,
Aspen, CO (US) 81611

(*) **Notice:** Subject to any disclaimer, the term of this
patent is extended or adjusted under 35
U.S.C. 154(b) by 0 days.

(21) **Appl. No.:** **09/461,708**

(22) **Filed:** **Dec. 14, 1999**

OTHER PUBLICATIONS

My Hands™—Complete Handprint Poem Kit product infor-
mation, source unknown, at least as early as Dec. 14, 1999.
My Hands™—Complete Handprint Poem Kit, *One Step
Ahead*, Perferred Issue 1999, p. 39

* cited by examiner

Primary Examiner—Sam Rimell

(74) *Attorney, Agent, or Firm*—Dorsey & Whitney LLP

Related U.S. Application Data

(63) Continuation of application No. 09/216,638, filed on Dec.
18, 1998, now Pat. No. 6,022,219.

(51) **Int. Cl.**⁷ **G09B 11/10**

(52) **U.S. Cl.** **434/84; 434/81**

(58) **Field of Search** **434/81, 84, 88,**
434/96, 98

(56) **References Cited**

U.S. PATENT DOCUMENTS

| | | | | | |
|-----------|---|---------|------------|-------|----------|
| 1,205,779 | * | 11/1916 | Peck | | 434/84 X |
| 1,901,861 | * | 3/1933 | Baker | | 434/84 X |
| 2,932,906 | * | 4/1960 | Chamberlin | | 434/84 |
| 3,604,558 | * | 9/1971 | Frerebeau | | 434/84 X |
| 3,768,177 | * | 10/1973 | Thomas | | 434/81 |
| 4,604,062 | * | 8/1986 | Woods | | 434/88 |
| 4,696,400 | * | 9/1987 | Warman | | 434/88 X |
| 5,772,247 | * | 6/1998 | Legrand | | 434/84 X |

(57) **ABSTRACT**

A unique painting process and an associated kit including
the materials required for practicing the method. The method
includes the acts of providing a background media providing
a paint source, dipping the posterior of the infant in the paint,
and stamping the posterior on the background media to
create stamping prints. The kit of the present invention
includes a flat, flexible backing piece, at least one paint
bottle attached to the backing piece, at least one reservoir
attached to the backing piece, at least one painting tool
attached to the backing piece, and a plastic cover having a
periphery, the plastic cover positioned over the protective
cover, plurality of paint bottles, plurality of reservoirs, and
plurality of paint brushes, and attached around its peripheral
edge to the backing piece.

9 Claims, 5 Drawing Sheets

(1 of 5 Drawing Sheet(s) Filed in Color)





Fig. 1

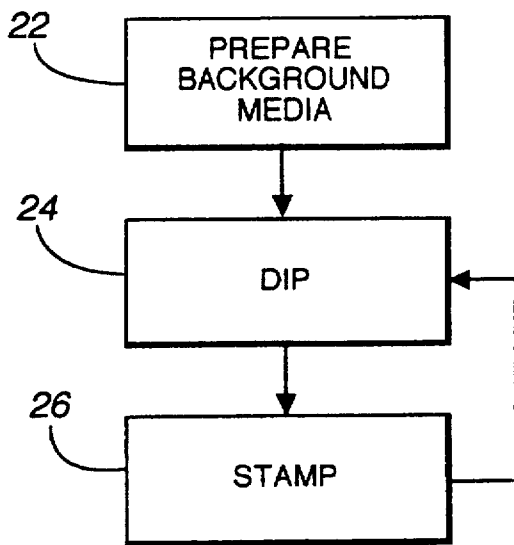

Fig. 2

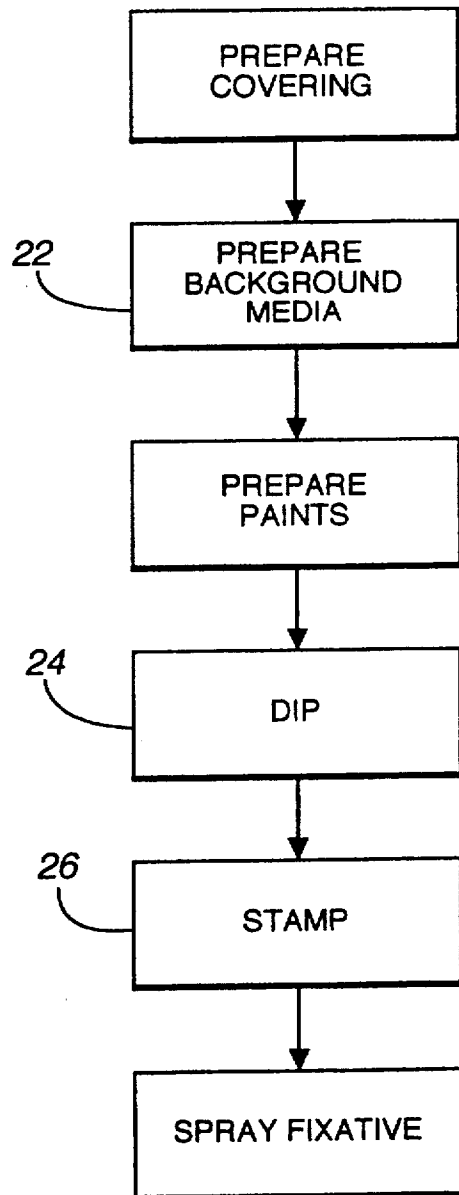

Fig. 3

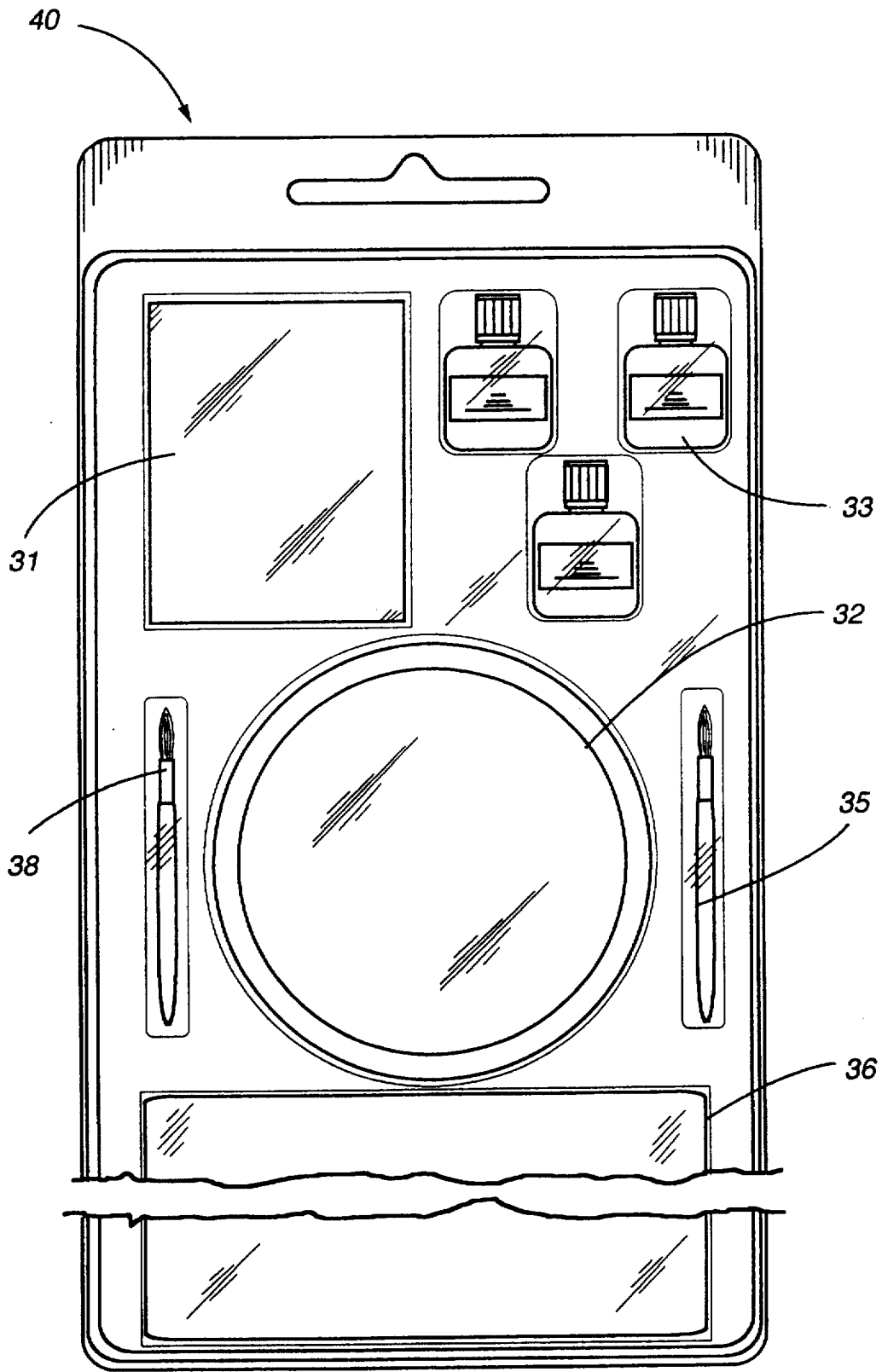

Fig. 4

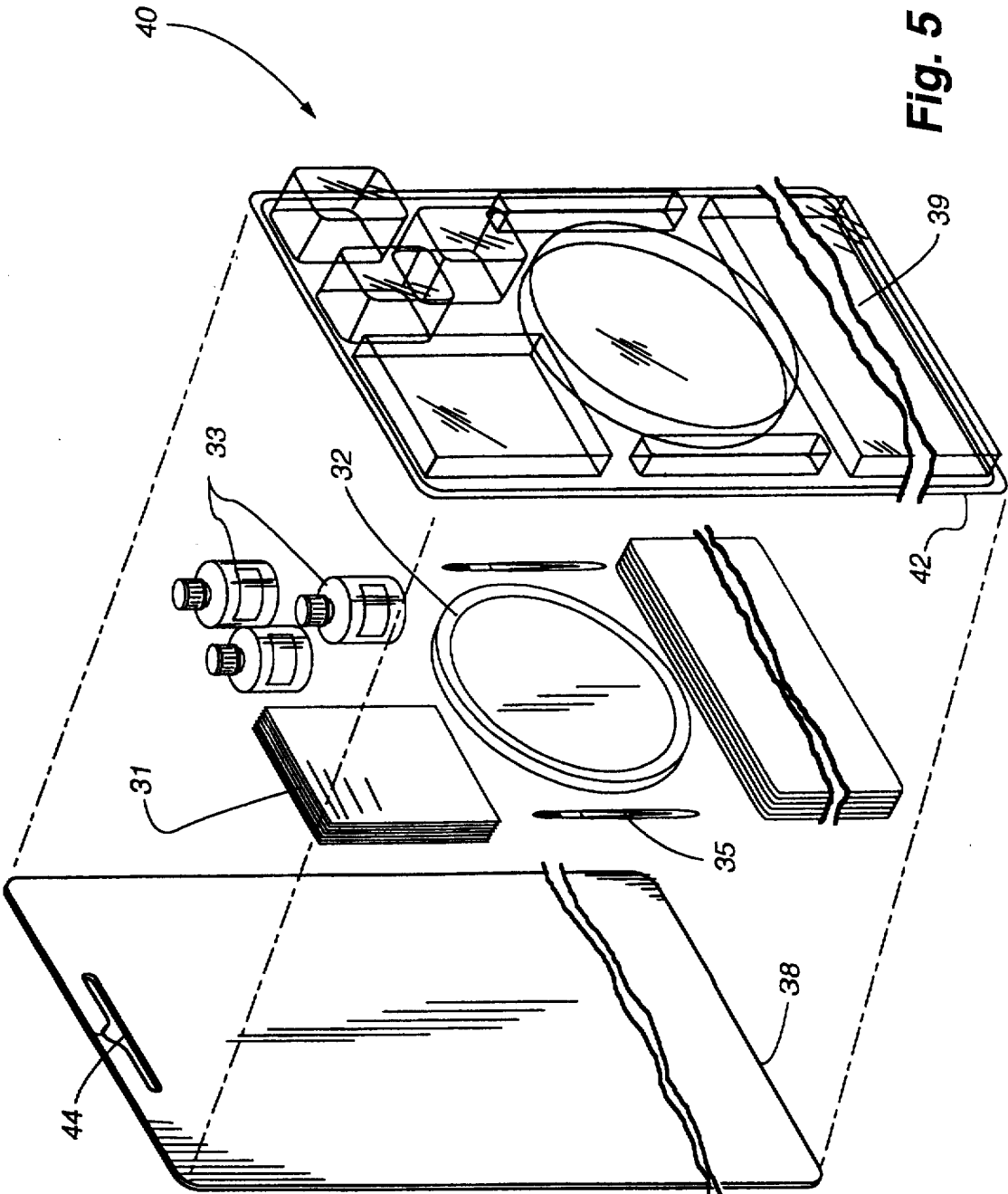

Fig. 5

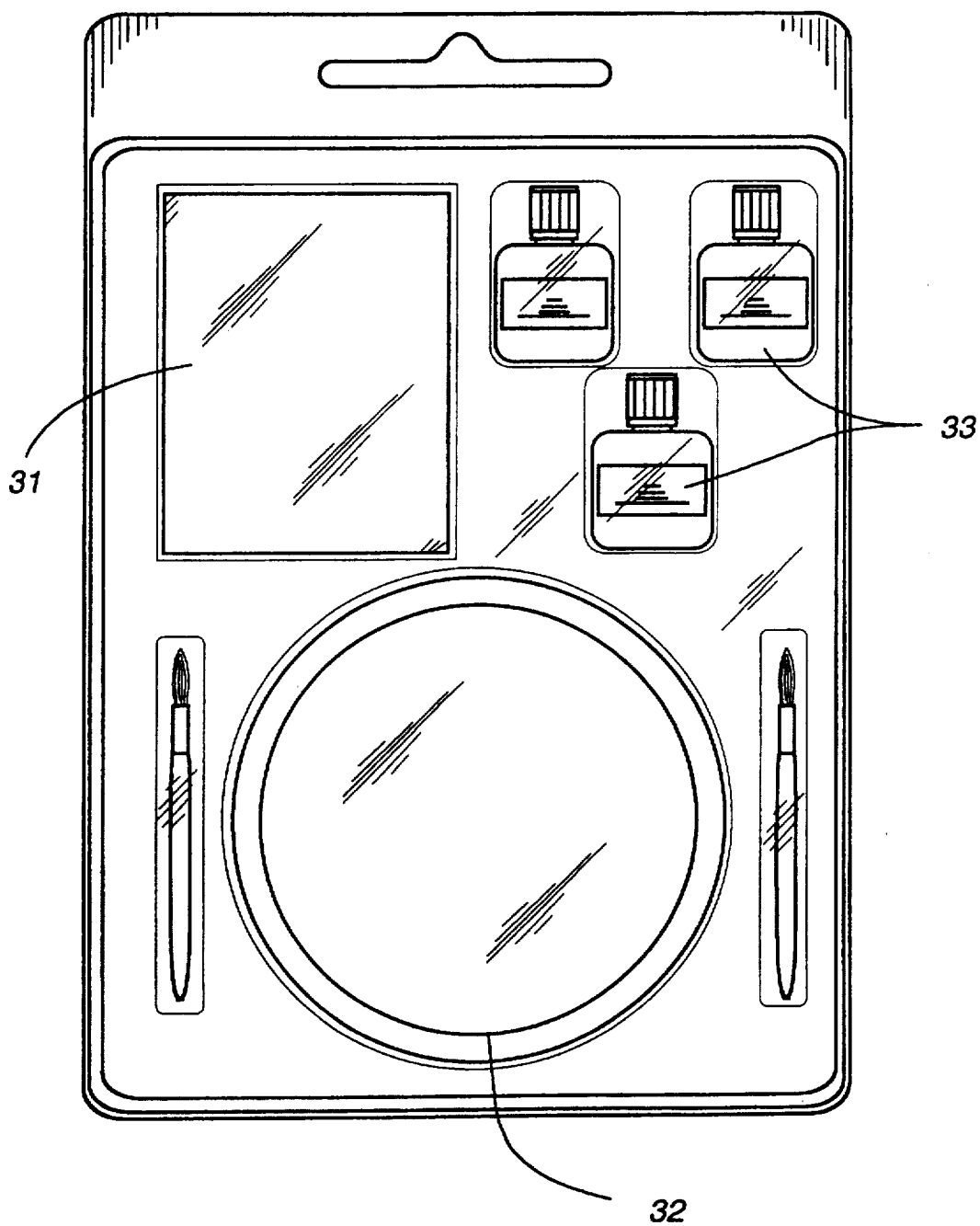

Fig. 6

PAINTING KIT AND RELATED METHOD

This is a continuation of application Serial No. 09/216, 638, filed on Dec. 18, 1998, now U.S. Pat. No. 6,022,219, which is hereby incorporated by reference in its entirety.

FIELD OF THE INVENTION

This invention relates to a painting kit and the associated method for its use. More particularly, this invention relates to a pre-packaged painting kit for use in association with an infant's posterior to create highly stylistic designs on a surface suitable for display.

BACKGROUND OF THE INVENTION

The addition of a newborn infant to a family inspires feelings of nostalgia and the related desire to create a lasting remembrance of the child's infancy. There are many ways to create this lasting remembrance, including bronzing a baby shoe, photography, videography, and making hand and feet prints. These types of products satisfy the need of a remembrance, but are all either utilitarian or unfinished in nature, and are very recognizable as mementos.

The existing types of remembrances are easily recognizable as just that—a whole or part of a baby or infant used to create a lasting impression. There is no known kit available, or method associated therewith, to assist in creating a remembrance that results in a fine art end product which is not easily recognized as merely a remembrance.

It is with these goals in mind that the instant invention was created.

SUMMARY OF THE INVENTION

The present invention relates to a unique painting process and a painting kit used to practice the process. The process includes the preparation of a protective covering on a work surface, placing a background media to be painted on the protective covering, placing a reservoir on the protective covering, filling the reservoir with paint, dipping the posterior of the infant in the paint, and stamping the painted posterior on the background media to create a finished product.

The kit of the present invention includes a flat, flexible backing piece (such as cardboard), a protective cover folded into a compact size and positioned on the backing piece, a plurality of paint bottles positioned on the backing piece, a plurality of reservoirs positioned on the backing piece, and a transparent plastic sheet covering the protective cover and plurality of paint bottles, reservoirs and painting tools, and attached around its peripheral edge to the backing piece. In more detail, a background media portion can also be included on the backing piece and under the plastic covering.

Other aspects, features and details of the present invention can be more completely understood by reference to the following detailed description of a preferred embodiment, taken in conjunction with the drawings, and from appended claims.

BRIEF DESCRIPTION OF THE DRAWINGS

The file of this patent contains at least one photograph executed in color. Copies of this patent with color photograph will be provided by the Patent and Trademark Office upon request and payment of the necessary fee.

FIG. 1 is a color photograph of a finished product obtained by practicing the present invention.

FIG. 2 is a flow chart representing the steps of the method of the present invention.

FIG. 3 is a flow chart of an alternative embodiment of the method of practicing the present invention resulting in a finished product like that shown in FIG. 1.

FIG. 4 is a plan view of a painting kit of the present invention with which the method of FIGS. 2 and 3 may be practiced.

FIG. 5 is an exploded view of the painting kit shown in FIG. 4.

FIG. 6 is a plan view of an alternative embodiment of a painting kit of the present invention.

DETAILED DESCRIPTION OF THE PREFERRED EMBODIMENT OF THE INVENTION

The present invention is directed at a method of creating unique and distinctive products in which paint is applied to the posterior of an infant and an impression of the infant's posterior is made upon a prepared surface by stamping the painted posterior on the prepared surface. In a preferred embodiment of the product created with the method of the present invention, the prepared surface or background media is a sheet of poster board onto which multiple impressions of the infant's posterior are stamped to create an abstract work of art. In an alternative embodiment, the prepared surface is a tshirt onto which one or more impressions of the infant's posterior are placed. Preferably, articles used to practice the method of the present invention are packaged in a kit, for convenient use.

A painting **10** made by practicing the method of the present invention is shown in FIG. 1. Painting **10** consists of individual impressions **12** of an infant's posterior arranged in an abstract design, with each impression being generally heart-shaped. A plurality of impressions are made by applying paint to an infant's posterior and "stamping" the painted posterior onto a prepared surface (or background media). It may be appreciated that the orientation of each individual impression is selected to obtain a desired end result. If desired, other elements may be added to the painting using a paint brush or other implement.

More particularly, unique products are created in accordance with the method steps shown in FIG. 2, by first preparing a surface (step **22**), dipping the posterior of an infant in a shallow reservoir of paint (step **24**), and stamping the paint-covered posterior on the surface (step **26**). The dipping and stamping steps **24** and **26** are repeated several times until the desired density, placement and color combination of impressions are made. Most preferably, the infant is at most six months old. Six months of age or younger is preferable because the infant is not too active and can be handled more easily than an older infant. A more detailed method is shown in FIG. 3, and includes the steps of preparing the covering, preparing the background media, preparing the paints, dipping the posterior of the infant, stamping the posterior of the infant on the background media, and after drying, spraying the fixative on the paint. The steps of dipping and stamping can be repeated as often as desired, with the optional step of cleaning the infant's posterior when changing paint colors.

Referring now to FIGS. 4 and 5, when practicing the method of the present invention, it is desirable to utilize a plastic, paper or cloth protective covering **31**, preferably approximately 4'x4', to protect the floor, carpet or other work surface from paint. Protective covering **31** can be larger or smaller depending on the work surface on which the method

is performed. While a plastic covering is preferred, butcher paper is also acceptable. Newspaper can be used but is not preferred, because it increases the chances of smudging any final work product.

The method of the present invention is most preferably practiced with at least one shallow reservoir 32 containing paint into which the infant's posterior is dipped. While reservoir 32 may be a bowl, pie tin, baking pan or plate-shaped reservoir, most preferably reservoir 32 is a plastic plate of approximately 10 $\frac{1}{4}$ " to 10 $\frac{3}{8}$ " in diameter. Although plastic plates are preferred, paper plates can also be used. Plate shaped reservoirs 32 are preferred because the paint easily spreads in a consistently thin layer over the surface of the plate, with the circumferential upper extending lip of the plate maintaining the paint inside the plate. However, the lip of such plates do not extend so high as to interfere with the application of the paint to the infant's posterior during dipping. More than one reservoir 32 should be used if a plurality of different colored impressions are to be made.

Finger paints 33, especially non-toxic brands such as Palmer paints, Crayola, or Rich Art, are preferred.

The surface 34 (FIG. 1) to be painted is preferably poster board at least $\frac{1}{4}$ " thick. While thinner poster board or other surface could be used, it has been found that poster board having the $\frac{1}{4}$ " thickness is sufficiently rigid to withstand the stamping process, is easily manipulated, thereby reducing smudging, and may be matted and framed, if desired. White or off-white poster board is preferable since it allows virtually any color combination of paint. Colored poster board can also be used if desired. The size of the background media has no limitation other than what is practicable. It has been found that 20"×30" sheets of poster board, which are readily available in most stores, are easily handled and may be framed.

A painting tool 35, such as a small paint brush or a small poly-brush (artist's) sponge on a stick handle, may be used to spread or mix paint on the plate. One brush or sponge should be available for each color of paint. Preferably, if a poly-brush sponge is used, the sponge should have a size of approximately 1"×2" or 2"×2".

Further, it is advantageous to have cleaning materials available, such as baby wipes available under the brand name Chubs or Huggies. A clean, dry diaper should also be available.

The method of the present invention may be practiced on any large flat surface, such as a floor or table where the background media can be fully supported in a flat, horizontal manner and all sides easily accessed. Initially, the work area is covered is covered with protective covering 31. Background media 34 is then centered on protective covering 31. Positioning background media 34 in the center of protective covering 31 helps minimize the splattering of paint onto the work surface.

The painting materials are then prepared. First, reservoirs 32, such as paper plates, are positioned on protective covering 31. Reservoirs 32 serve as a palate for paints 33, and one paper plate should be used for each color. Next, paint 33 is poured into reservoirs 32 to a depth $\frac{1}{16}$ " to $\frac{1}{8}$ ". Filling reservoirs 32 with paint 33 over $\frac{1}{8}$ " deep results is an unnecessarily messy process, while underfilling reservoirs 32 with paint 33 below $\frac{1}{16}$ " deep does not allow for repeated dipping and stamping. Paint 33 may be distributed evenly in reservoirs 32 with a small paint brush 35 or artist's sponge.

The infant's posterior is then dipped into a reservoir 32 and covered with paint 33. It is desirable to roll the infant slightly for good coverage. There are two different ways to

hold the infant to obtain desirable dipping results. If the infant has good head and neck control, the infant can be positioned facing away from the adult, who securely grasps each of the infant's thighs with one hand, gently pressing the thighs together. The infant's body should rest against the forearms and elbows of the adult. The posterior of the infant can then be dipped into the reservoir. If the infant does not have good neck and head control, then the infant's head and neck should be supported with one hand, while placing the other hand under the infant's thighs. In this position, the infant's posterior is dipped into the reservoir and covered with paint.

The painted posterior is then stamped or pressed on the background media 34. It is preferable to roll the infant's posterior slightly when in contact with the background media to create a clear print 12. If the infant is held in the first manner described above, the infant is rolled gently forward, away from the adult, for an optimal print. If the infant is held in the second manner described above, an optimal posterior print is obtained by rolling the infant either forward or side to side, depending on the orientation of the infant with respect to the adult.

The posterior of the baby is then cleaned with a wipe. Thereafter, the dipping, stamping and cleaning steps may be repeated to obtain a desired result. It can be readily appreciated that the prints can be placed in a random or regular pattern. For example, all prints may be oriented in one direction. The prints may appear to be hearts, flowers, other objects or an abstract design.

It is not necessary to let one color or stamp dry before proceeding to the next color stamp. The bleeding of one color into another can be part of the effect of the end result. If a runny look is desired, then the reservoir should be filled to a greater depth with paint. If a splotchy effect is desired, less paint should be placed in the reservoir.

Optionally, the printed product may be treated with a fixative agent in preferably spray form. A suitable fixative agent is a no odor matte fixative offered under the trade name Blair. The fixative sets the paint after drying.

Materials for practicing the method of the presented are presented in kit form, as shown in FIGS. 4, 5 and 6. The preferred kit 40 shown in FIGS. 4 and 5 a plastic sheet floor covering 31, a plurality of plate reservoirs 32 to hold the paint 33, a plurality of paint colors 33 for use, and a painting tool 35, such as a paint brush, one for each plate. Alternatively, the paint brush could be replaced with the poly-sponge, or a combination of paint brushes or poly-sponges could be included. A section of background media 36, such as poster board, is also included in the kit.

The package 40 for holding each of the materials to form the kit can include a blister pack, which has a cardboard, flexible backing piece 38 with instructions and illustrations on the back side thereof, and the required materials denoted above positioned on and attached to the front side of the backing piece. The materials are secured to backing piece 38 either by a shaped-conforming or rectangular plastic cover 39 fixed around its perimeter edge to the backing piece, such as by an adhesive material or staples. Plastic cover 39 is clear and allows the potential purchaser to view each of the materials easily. Advertisements and other information can be positioned on the plastic cover or the front surface of the backing piece. Backing piece 38 can have any shape, but is preferably rectangular. A hanging hole 41 having an elongated laterally extending slot with a bite formed in its upper edge is found on the top edge of backing piece 38.

The orientation of the materials in package 40 is important for drawing the attention of the potential purchaser, and

5

also for the efficient use of space, which reduces costs and increases density of packing on shelves. Preferably, in the top row of the package protective cover 31 is folded and positioned on the left portion of the top row, as shown in FIG. 4, and the plurality of paint bottles 33 are aligned in the right portion of the top row. Any number of paint bottles 33 could be included, however, preferably three paint bottles 33 are included to allow for a variety of uses and colors. In the second row of the package, a plurality of stacked plates 32 are positioned in the center of the second row with the paint brushes 35, one for each plate, positioned on either side of the plates. Plates 32 are stacked for efficient use of space. In the third row of the package, background media 34, such as poster board, is positioned. Packages can be made to either include or exclude the poster board as is desired for efficient shelf space usage and different product offerings. The background material could also be positioned between the paint bottles 33, reservoirs 32, protective cover 31 and paint brushes and the backing piece 38. This would help minimize the size of the package.

FIG. 5 shows an exploded view of the materials in the package 40 which forms the kit. Plastic cover 39 is attached to backing piece 38 at its curved periphery 42. Periphery portion 42 lays flat against backing piece 38 for a secure attachment.

FIG. 6 shows the same package as FIG. 5 with the poster board excluded. This allows the package to take up less shelf space, and provides an alternative to the full complement package.

The package could take different forms if desired, such as being enclosed in a brief-case type structure for portability and ease of repeated use.

By practicing the inventive method set forth above, the user can create an attractive remembrance of a baby, which also doubles as a painting which warrants life-long display. The result is a unique, intriguing product that is virtually unidentifiable as being a remembrance of a baby. The kit created to support the practice of the method of the present invention includes all the material required for practicing the method in a convenient, cost-effective, and space efficient package.

6

Although the present invention has been described with a degree of particularity, it is understood that the present disclosure has been made by way of example, and changes in detail or structure may be made without departing from the spirit of the invention, as defined in the appended claims.

I claim:

1. A method of painting using the posterior of an infant, said method comprising the acts of:

providing a background media;

providing a paint supply;

dipping the posterior of the infant in said paint supply; and stamping the posterior on said background media to create stamping prints.

2. A method as defined in claim 1, wherein:

said dipping and said stamping steps are repeated in sequence.

3. A method as defined in claim 1, further comprising the act of:

spraying a fixative agent on said background material to set said stamping prints.

4. A method as defined in claim 2, further comprising the act of:

spraying a fixative agent on said background material to set said stamping prints.

5. A method as defined in claim 1 further comprising the act of rolling the posterior of the infant during the stamping step.

6. A method as defined in claim 2 further comprising the act of rolling the posterior of the infant during each stamping step.

7. A method as defined in claim 1 further comprising the act of overlapping subsequent stampings.

8. A method as defined in claim 1 further comprising the act of ordering stampings in a regular pattern.

9. A method as defined in claim 1 further comprising the act of ordering stampings in a random pattern.

* * * * *



US006213778C1

(12) **EX PARTE REEXAMINATION CERTIFICATE** (5449th)
United States Patent
Cohen

(10) **Number:** **US 6,213,778 C1**
(45) **Certificate Issued:** **Jul. 11, 2006**

(54) **PAINTING KIT AND RELATED METHOD**

(75) **Inventor:** **Elise Cohen**, 814 W. Bleeker, Unit C-3,
Aspen, CO (US) 81611

(73) **Assignee:** **Elise Cohen**, Aspen, CO (US)

Reexamination Request:

No. 90/006,171, Jan. 24, 2002

Reexamination Certificate for:

Patent No.: **6,213,778**
Issued: **Apr. 10, 2001**
Appl. No.: **09/461,708**
Filed: **Dec. 14, 1999**

Related U.S. Application Data

(63) Continuation of application No. 09/216,638, filed on Dec. 18, 1998, now Pat. No. 6,022,219.

(51) **Int. Cl.**
G09B 11/10 (2006.01)

(52) **U.S. Cl.** **434/84; 434/81**

(58) **Field of Classification Search** 434/81,
434/84, 88, 96, 98

See application file for complete search history.

(56) **References Cited**

PUBLICATIONS

“Handprint Apron,” Family Fun Crafts. Copyright 1997 Disney Enterprises, Inc., p. 186.*

“Tulip Butts,” badart.com. Steve Murmer, 1997. <http://www.badart.com/tulipbutt.html>.*

Veronsky’s Webb Page, Veron Floresca. Last Modified Oct. 14, 1999 <http://web.singnet.com.sg/veronbf/tulipbutt.html>.*

<http://www.winternet.com/mikelr/siteindex.htm>, <http://www.winternet.com/mikelr/badart.html>.*

Notes, Art, Portraits, and Filler—1999 Notebook <http://www.stare.com/1999/intervall3.html>.*

* cited by examiner

Primary Examiner—Kien T. Nguyen

(57) **ABSTRACT**

A unique painting process and an associated kit including the materials required for practicing the method. The method includes the acts of providing a background media providing a paint source, dipping the posterior of the infant in the paint, and stamping the posterior on the background media to create stamping prints. The kit of the present invention includes a flat, flexible backing piece, at least one paint bottle attached to the backing piece, at least one reservoir attached to the backing piece, at least one painting tool attached to the backing piece, and a plastic cover having a periphery, the plastic cover positioned over the protective cover, plurality of paint bottles, plurality of reservoirs, and plurality of paint brushes, and attached around its peripheral edge to the backing piece.



1
EX PARTE
REEXAMINATION CERTIFICATE
ISSUED UNDER 35 U.S.C. 307

THE PATENT IS HEREBY AMENDED AS
INDICATED BELOW.

2
AS A RESULT OF REEXAMINATION, IT HAS BEEN
DETERMINED THAT:

Claims **1-9** are cancelled.
5 New claims **10** and **11** are cancelled.

* * * * *