

March 1, 1927.

1,619,183

D. B. BRADNER ET AL

PROCESS OF PRODUCING SMOKE CLOUDS FROM MOVING AIRCRAFT

Filed May 8, 1925

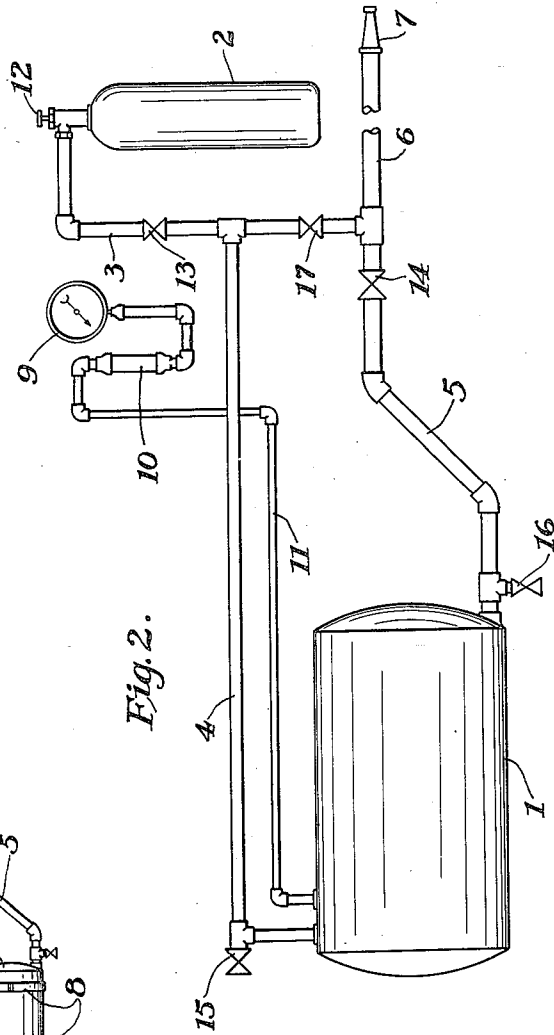
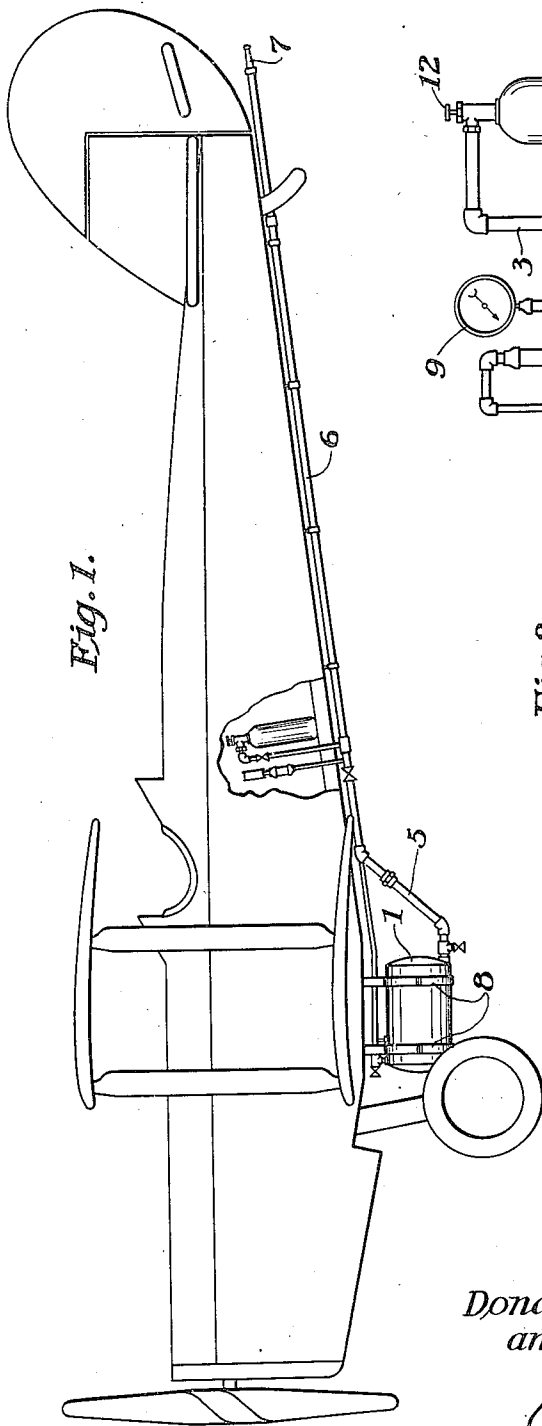

Donald B. Bradner INVENTORS.
and Nicholas E. Oglesby
BY

Chas. Silver ATTORNEY.

Patented Mar. 1, 1927.

UNITED STATES PATENT OFFICE.

DONALD B. BRADNER AND NICHOLAS E. OGLESBY, OF EDGEWOOD, MARYLAND.

PROCESS OF PRODUCING SMOKE CLOUDS FROM MOVING AIRCRAFT.

Application filed May 8, 1925. Serial No. 23,981.

This invention relates to a process of spraying or sprinkling smoke-producing liquids from bodies moving with a high velocity and has more specific application to the sprinkling of smoke-producing liquids from aircraft, such as aeroplanes, dirigibles, etc.

Among the objects of this invention is the provision of a process whereby smoke-producing liquids may be dropped from aircraft, wherein the liquid reacts with one or more of the constituents of the air or atmosphere and generates a smoke screen as it falls. This is an improvement over the present means of generating smoke screens wherein the smoke material is dropped to the ground in containers or else is set out on the ground, and wherein the success of the operation of producing the screen is dependent on the rise of a smoke cloud.

A further object of this invention is the provision of a process which may be employed for laying screens of smoke from aeroplanes to protect the planes from anti-aircraft attack or to protect land fortifications, troops, or ships from enemy fire.

A still further object of this invention is the provision of a process for producing long and extensive fronts of smoke in an economic, safe and rapid manner.

Other, further and more specific objects of the invention will become readily apparent to persons skilled in the art from a consideration of the following description when taken in conjunction with the accompanying drawing.

When a liquid is dropped from an elevation at rest with respect to the air it will fall to the ground in the form of stable drops. If, however, the liquid be dropped from a body moving at high velocity, the liquid will immediately upon release become broken up into a mist and all of the liquid or a considerable portion thereof will be dispersed in the air and not reach the ground. By ejecting the liquid under pressure from an aeroplane or other moving aircraft so that the liquid leaves the plane at approximately the same velocity as the plane passes through the air but in a substantially opposite direction, the liquid will fall as if poured from an elevation at rest, and travels to the ground in substantially stable drops. The present invention makes use of this method of ejecting smoke-producing liquids from moving aircraft.

This invention is not limited to any class of smoke-producing liquids and may also be applied to solutions of solids in liquids. The success and effectiveness of the smoke screen is largely dependent on the chemical and physical properties of the liquid employed. We prefer to employ a smoke-producing liquid such as $TiCl_3$, $SnCl_4$, oleum and chlorosulphonic acid. We may, however, use other mixtures or solutions, for example a solution of sulphur trioxide in chlorosulphonic acid. These smoke-producing materials are not stable in the air but react with one or more constituents of the air to form substantially stable products.

When these smoke-producing liquids are ejected under pressure from an aeroplane or other moving aircraft so that the liquid leaves the plane at approximately the same velocity as the plane passes through the air but in a substantially opposite direction, the liquid falls in the form of relatively stable drops and reacts with the constituents of the air to form a smoke screen. The effect produced is the generation of a falling smoke curtain, which reaches the ground in the form of a long, high screen. Dependent on the height at which the plane is travelling when the liquid is released, the smoke curtain may be made to hang in the air, or may be made to rest on the ground.

Reference is to be had to the accompanying drawings wherein we have illustrated, more or less diagrammatically, an apparatus which is suitable for carrying out our invention. Fig. 1 is a side elevation of an aeroplane equipped with the special apparatus for carrying out our invention. Fig. 2 is a detail view illustrating diagrammatically the parts of the apparatus.

The apparatus comprises a tank (1) for holding the liquid to be sprinkled. A pressure cylinder (2) containing compressed carbon dioxide or other suitable gas is connected to the tank (1) by the conduit (3) and the branching conduits (4) and (5). The conduit (6) connects with the conduit (5) and terminates at the back of the aeroplane in a nozzle (7). The tank (1) is fastened to the aeroplane by the straps or bands (8), and the cylinder (2) and the conduits are held in position by any suitable means.

The tank (1) is provided with a pressure gauge (9), and when handling corrosive substances provide a trap (10) in the line (11) from the tank (1) to the gauge (9). The

gauge side of the trap (10) contains a suitable non-corroding material, such as chlorinated paraffin oils, while the other side of the trap contains mercury. The gauge (9) is positioned convenient to the operator.

Compressed gas is supplied from the cylinder (2) thru the cylinder valve (12), conduit (3), valve (13) and conduit (4) to the tank (1) containing the liquid to be sprinkled. The liquid is forced from the tank (1) by the compressed gas thru the conduit (5), valve (14), conduit (6) and the nozzle (7) at the rear of the aeroplane.

The conduit (4) is also provided with a valve (15), which serves as an emergency pressure release outlet, and when the tank (1) is being filled this valve (15) serves as an air release outlet. The conduit (5) is provided with a valve (16) near the tank (1), this valve being used in the ordinary filling of the tank (1) with the liquid to be sprinkled. In the conduit (3) and located near the conduit (6) is a valve (17) which serves in an emergency for permitting the escape of pressure should a forced landing be necessary.

The tank (1) may be filled with the liquid to be sprinkled in any convenient manner. For example, air is allowed to escape by opening the valve (15) and the liquid is forced into the tank (1) through the valve (16), the valve (14) being closed during the operation. When the tank (1) has been filled the valves (15) and (16) are again closed.

In operating this device for sprinkling the liquid, it is advisable not to introduce pressure into the system until the plane has left the ground. All the valves being closed, valve (13) is opened and then valve (12) is opened gradually. Pressure immediately builds up in the system as shown by the gauge (9). Ordinarily, it is desirable to start with an initial pressure of 225 pounds per square inch in order that the pressure be maintained at the desired point while valve (14) is being opened and until attention can again be given to the pressure control. Valve (14) should be opened gradually in order to prevent a water hammer effect which might result in a broken connection. If decrease in pressure takes place at this point, valve (12) is again opened and manipulated so as to maintain the gauge pressure at about 170 lbs. per sq. in. This pressure will discharge approximately 300 pounds of liquid over a period of 20 seconds and of a distance of one half mile. After the tank has been completely discharged a rapid decrease in pressure will be noted. Ordinarily, it is advisable to allow the gas, for example carbon dioxide, to exhaust itself in order to clear all the conduits and lines.

This invention is applicable to various types of aeroplanes and aircraft, and the

amount of liquid which may be carried varies with the carrying capacity of the particular aircraft.

Although in this specific illustration we employ compressed carbon dioxide as the source of gas pressure, it is to be understood that our invention is not limited in this respect but that other gases which do not have undesirable chemical action on the liquid to be sprinkled may be employed, and that mechanical apparatus, for example a pump or air compressor, may be employed in lieu of the compressed carbon dioxide. Also, other smoke-producing liquids than those named herein may be employed without departing from the spirit of this invention.

In describing the operation of our device, a gas pressure of 175 lbs. per square in. of the liquid is given. This figure represents a value based upon the physical and chemical constants of the liquids sprinkled, the average speed of the plane, the size of the nozzle and the resistance of the conduits and fittings. By controlling the pressure of the gas in the tank containing the liquid to be sprinkled, the velocity of ejection may be made approximately equal to the velocity of the plane through the air at any given time.

In the practice of our invention, the actual velocity of the wind with reference to the ground is of substantially no importance, the vital consideration being the velocity of the moving aircraft in the air which is the factor resulting in the breaking up of the drops of liquid into smaller particles. By projecting the liquid from the moving aircraft with a velocity substantially equal and opposite to the velocity in the air of the moving aircraft, counter-longitudinal motion between the liquid and the air at the time of release of the liquid is prevented and the result is that the liquid falls as if poured from an elevation at rest, and travels to the ground in substantially stable drops. When the liquid is a smoke-producing material, which reacts with one or more constituents of the air to form substantially stable, visible products, the effect produced is that of a falling smoke curtain.

In the following claims, wherever reference is made to the velocity of the moving body, aircraft or airplane, it is intended to refer to the velocity in the air and not the speed relative to the ground.

The present invention is not limited to the specific details set forth in the foregoing examples which should be construed as illustrative and not by way of limitation, and in view of the numerous modifications which may be effected therein without departing from the spirit and scope of this invention, it is desired that only such limitations be imposed as are indicated in the appended claims.

We claim as our invention:

1. In a process of producing a smoke screen, ejecting from a moving body a liquid which reacts with a constituent of the air to produce a smoke, said body moving at a velocity sufficient to produce a highly dispersive action upon a liquid falling therefrom and said smoke-producing liquid being ejected in a direction substantially opposite to that of the moving body and at a velocity to counteract said dispersive action.

2. In a process of producing a falling curtain of smoke, ejecting from a moving body a liquid which reacts with a constituent of the air to produce a smoke, said body moving at a velocity sufficient to produce a highly dispersive action upon a liquid falling therefrom and said smoke-producing liquid being ejected in a direction substantially opposite to that of the moving body and at a velocity sufficient to counteract substantially all of said dispersive action.

3. In a process of producing a curtain of smoke, ejecting from a moving body a liquid which reacts with a constituent of the air to produce a smoke, said body moving at a velocity sufficient to produce a highly dispersive action upon a liquid falling therefrom and said liquid being ejected in the form of a spray, at a velocity substantially equal and in a direction substantially opposite to that of the moving body.

4. In a process of producing a smoke screen, ejecting from an aeroplane while flying a liquid which reacts with a constituent of the air to produce a smoke, said liquid being ejected in a direction substantially opposite to that of the moving aeroplane and the difference in velocity between the aeroplane and the liquid ejected therefrom not exceeding 20 miles per hour.

5. In a process of producing a falling curtain of smoke, ejecting from moving aircraft

a liquid which reacts with a constituent of the air to produce a smoke, said aircraft moving at a velocity sufficient to produce a highly dispersive action upon a liquid falling therefrom and said smoke-producing liquid being ejected in the form of a spray, in a direction substantially opposite to that of the moving aircraft and at a velocity sufficient to counteract the greater portion of said dispersive action.

6. In a process of producing a smoke screen, ejecting from a moving aeroplane a liquid which reacts with a constituent of the air to produce a smoke, said aeroplane moving at a velocity sufficient to produce a highly dispersive action upon a liquid falling therefrom, and said smoke-producing liquid being ejected at the rear of and backward to the motion of said aeroplane and at a velocity closely approaching that of the moving aeroplane.

7. In a process of producing a smoke screen, ejecting from a moving body liquid $TiCl_4$, said body moving at a velocity sufficient to produce a highly dispersive action upon a liquid falling therefrom and said $TiCl_4$ being ejected in a direction substantially opposite to that of the moving body and at a velocity to counteract said dispersive action.

8. In a process of producing a falling curtain of smoke, ejecting from moving aircraft liquid $TiCl_4$, said aircraft moving at a velocity sufficient to produce a highly dispersive action upon a liquid falling therefrom and said $TiCl_4$ being ejected in the form of a spray, in a direction substantially opposite to that of the moving aircraft and at a velocity sufficient to counteract the greater portion of said dispersive action.

DONALD B. BRADNER.
NICHOLAS E. OGLESBY.