

J. GORRIE
ICE MACHINE.

No. 8,080.

Patented May 6, 1851.

Fig: 1.

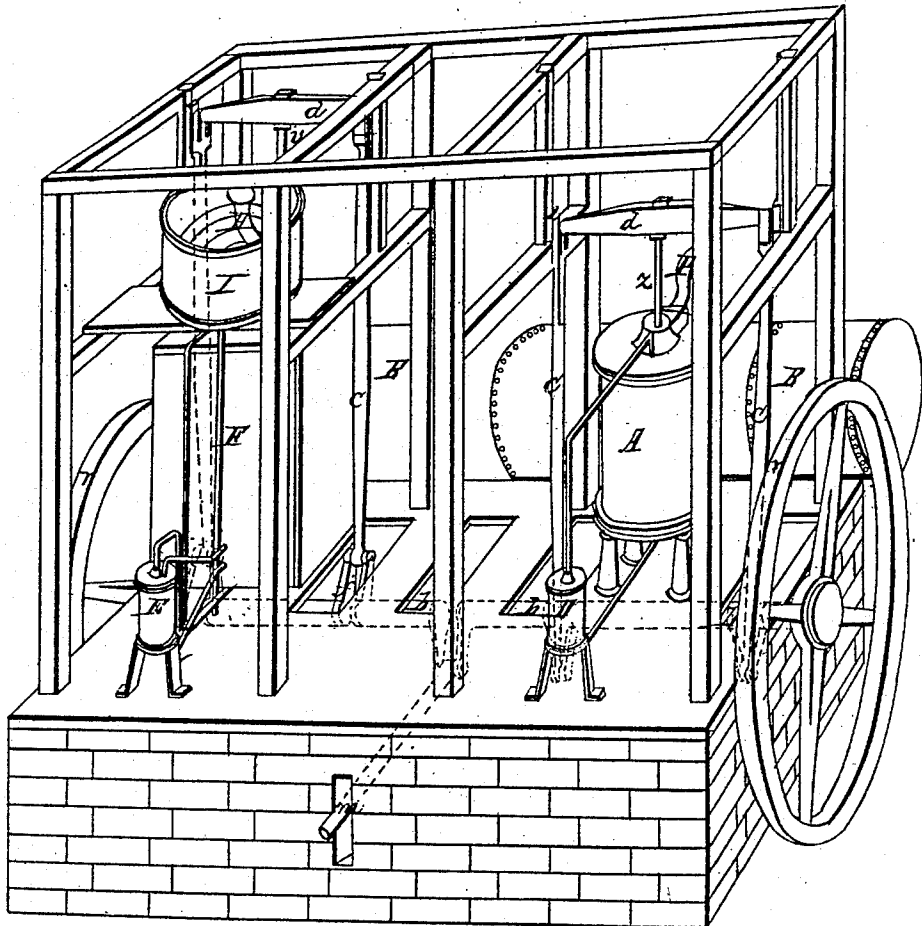

J. GORRIE.
ICE MACHINE.

No. 8,080.

Patented May 6, 1851.

Fig: 2.

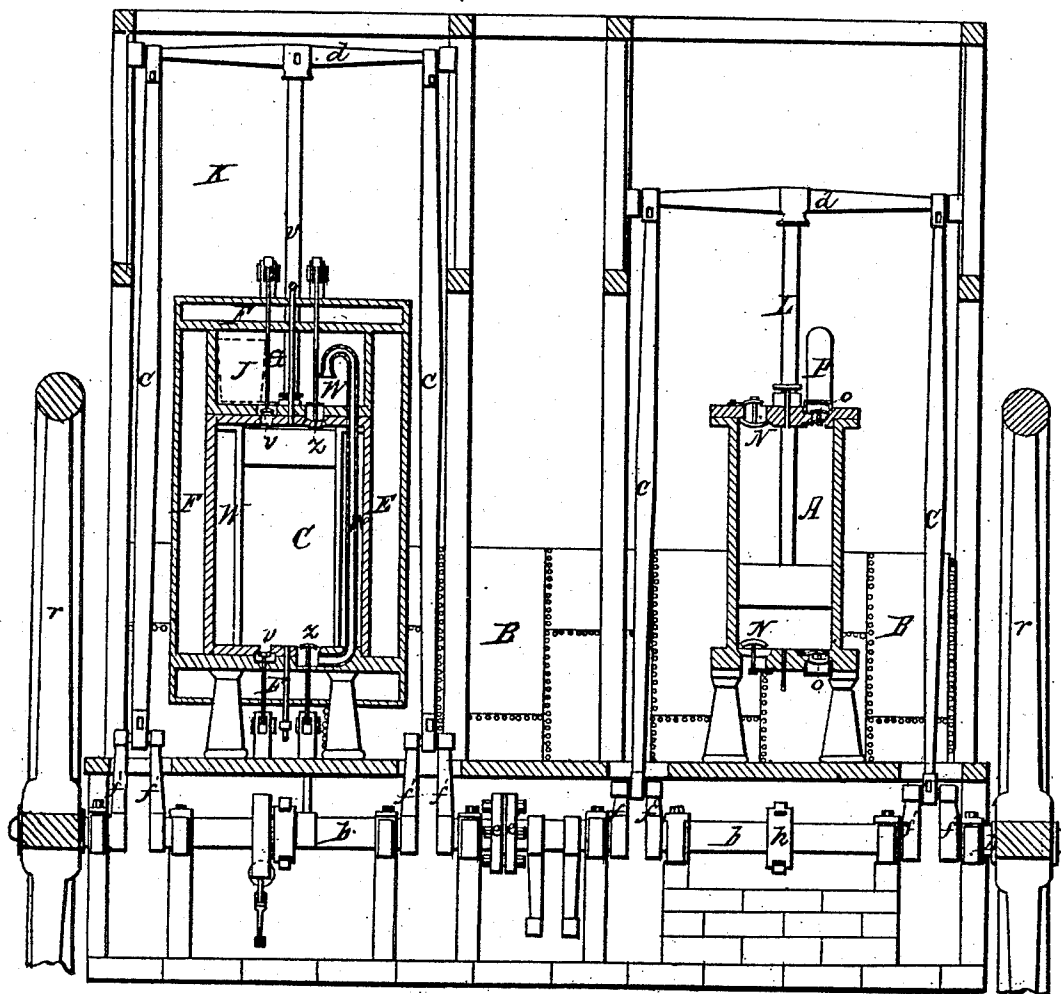

J. GORRIE.
ICE MACHINE.

No. 8,080.

Patented May 6, 1851.

Fig: 3.

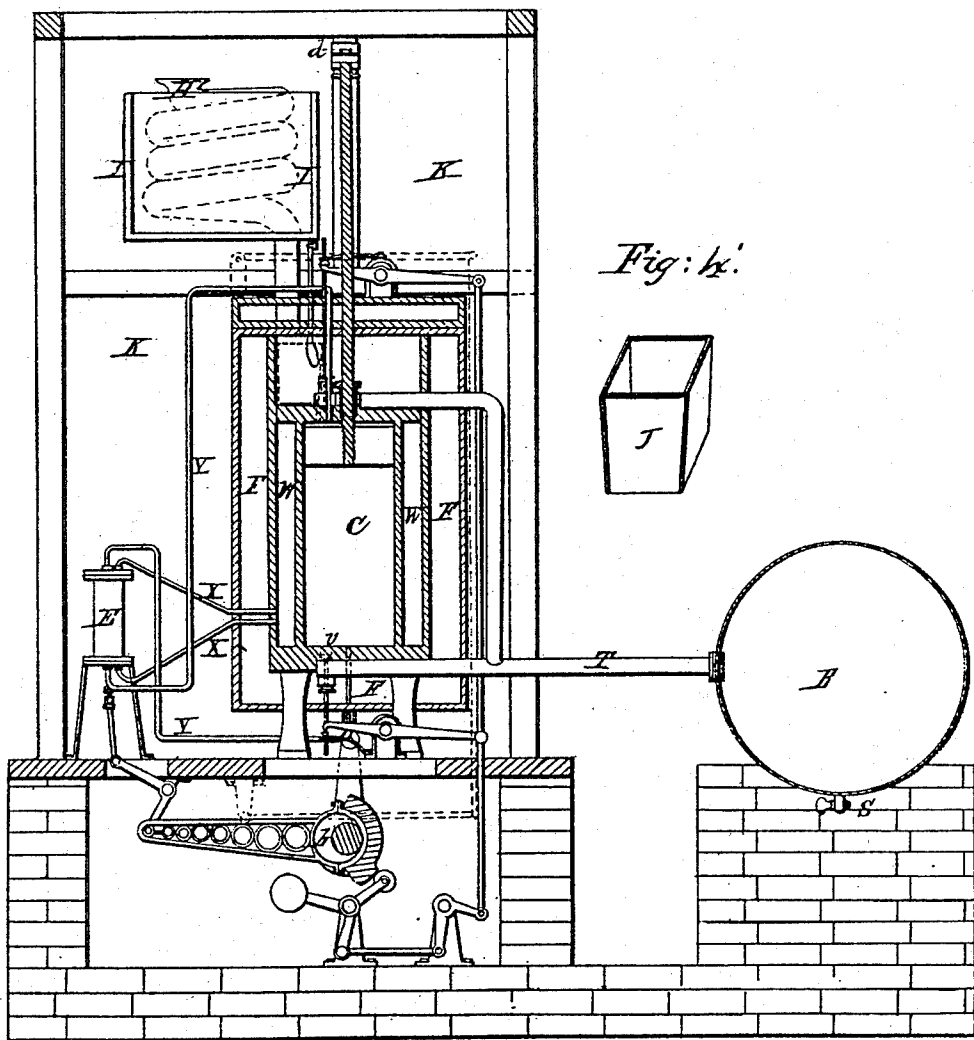

J. GORRIE.
ICE MACHINE.

No. 8,080.

Patented May 6, 1851.

Fig: 1x.

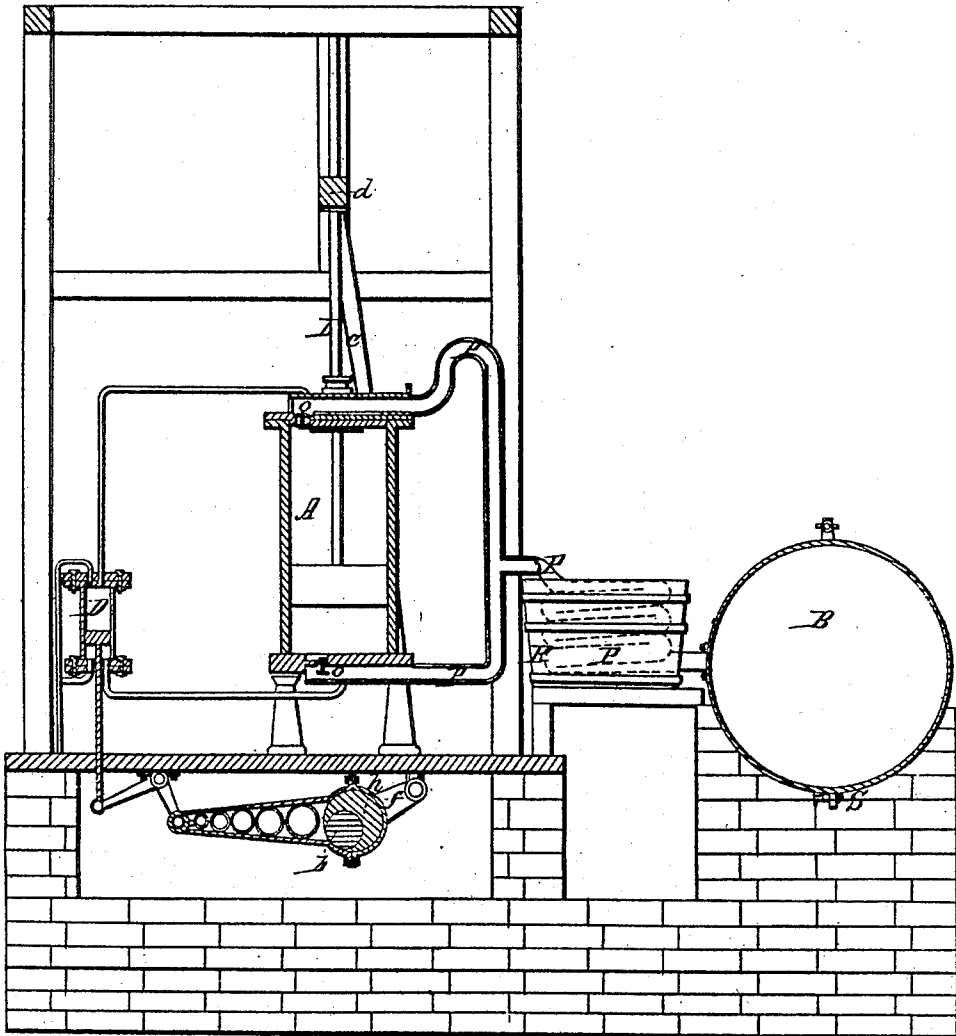

J. GORRIE.
ICE MACHINE.

No. 8,080.

Patented May 6, 1851

Fig: 5.

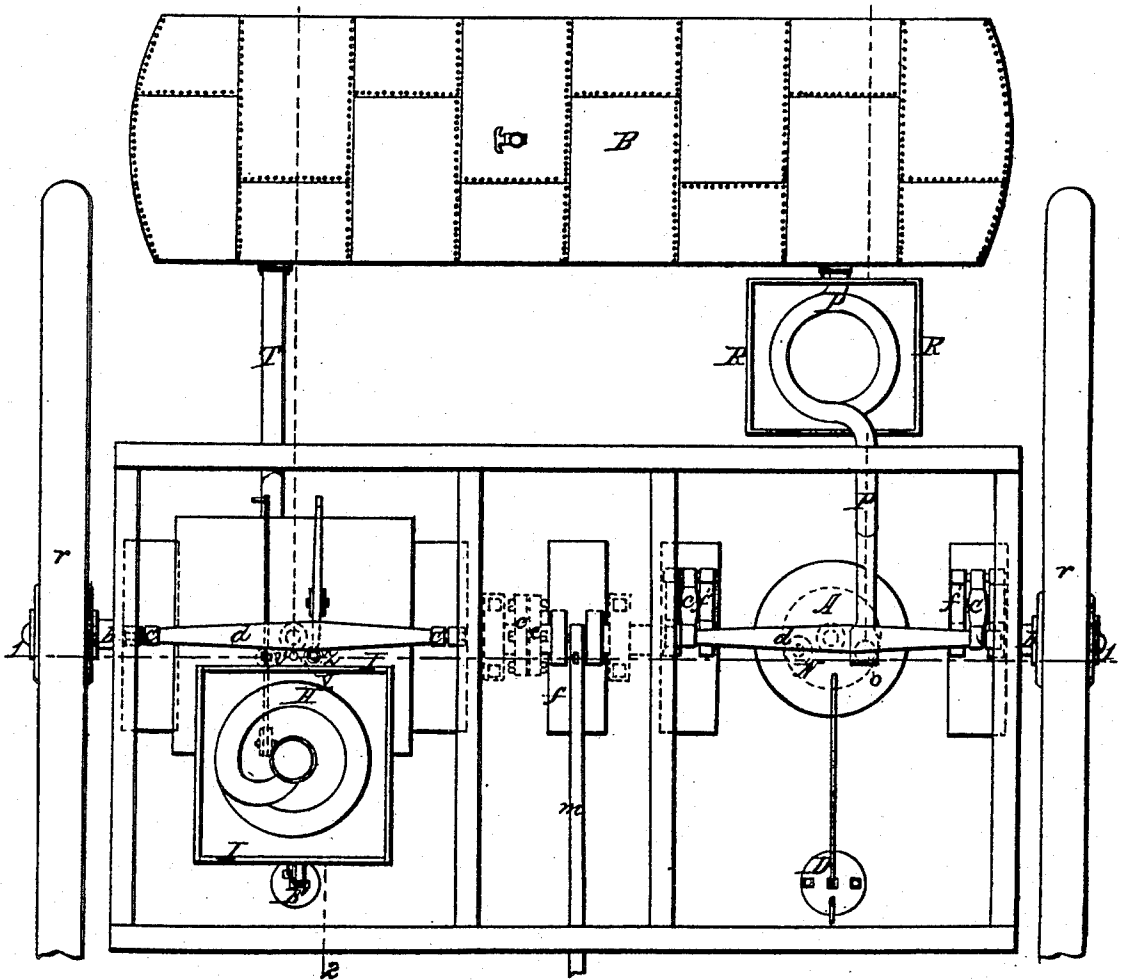

J. GORRIE.
ICE MACHINE.

No. 8,080.

Patented May 6, 1851.

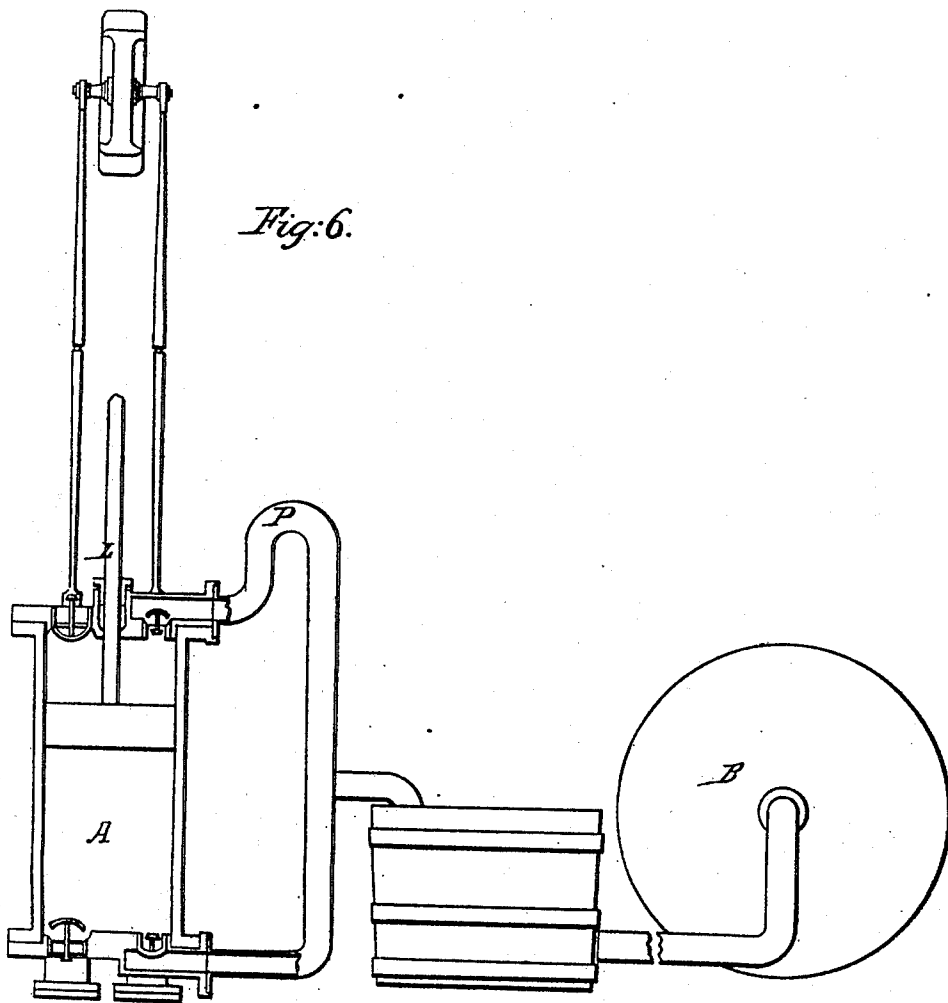

J. GORRIE.
ICE MACHINE.

8 Sheets—Sheet 7.

No. 8,080.

Patented May 6, 1851.

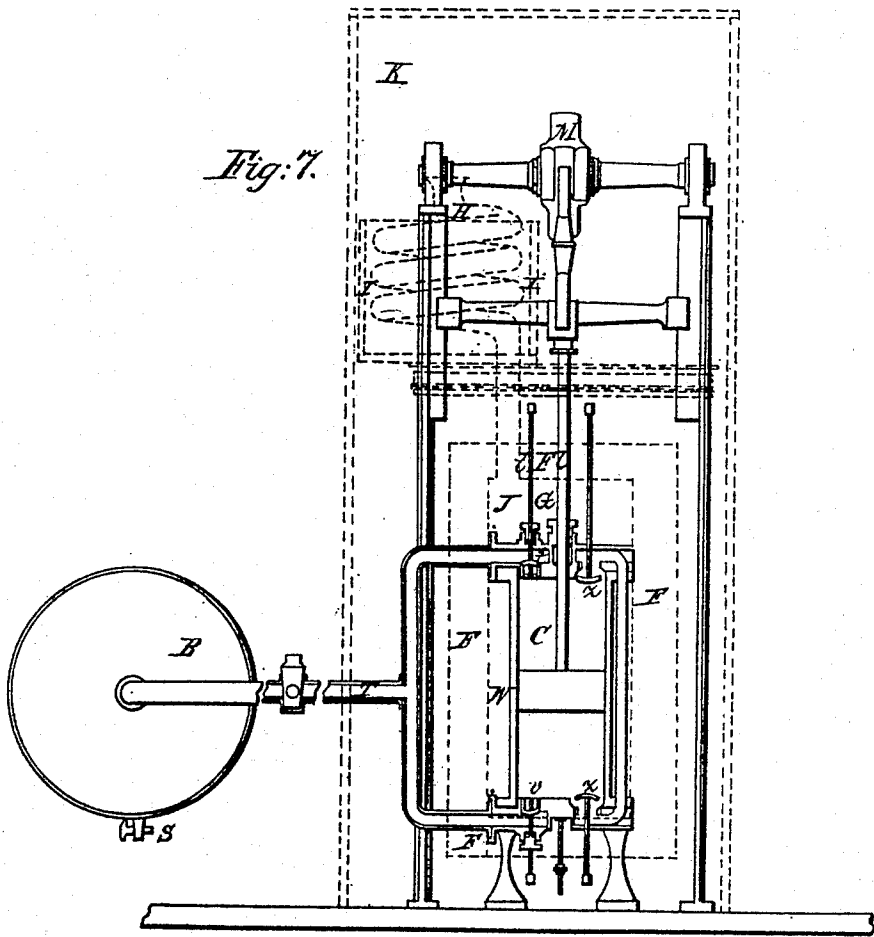

J. GORRIE.
ICE MACHINE.

8 Sheets—Sheet 8.

No. 8,080.

Patented May 6, 1851.

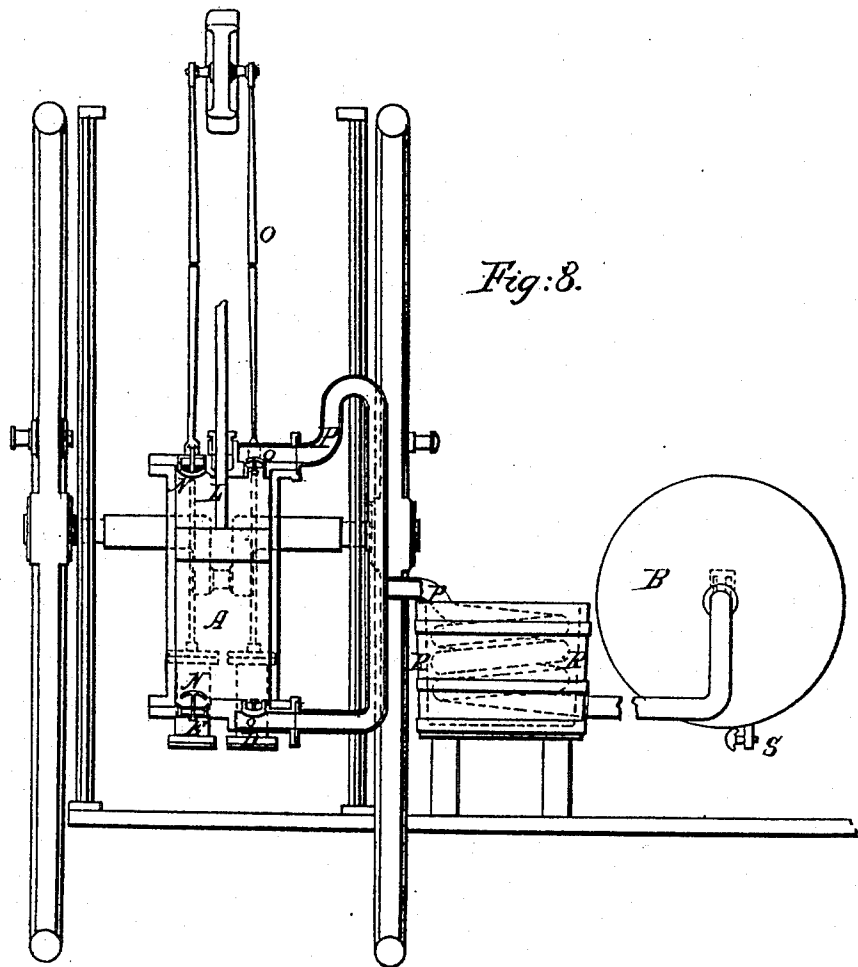

UNITED STATES PATENT OFFICE.

JOHN GORRIE, OF NEW ORLEANS, LOUISIANA.

IMPROVED PROCESS FOR THE ARTIFICIAL PRODUCTION OF ICE.

Specification forming part of Letters Patent No. 8,080, dated May 6, 1851.

To all whom it may concern:

Be it known that I, JOHN GORRIE, of the city of New Orleans, in the parish of Orleans and State of Louisiana, have invented a new and useful Machine for the Artificial Production of Ice and for General Refrigeratory Purposes, of which the following is a full, clear, and exact description, reference being had to the annexed drawings of the same, making part of this specification, in which—

Figure 1 is a perspective view of the machine. Fig. 2 is a vertical longitudinal section, taken through the condensing-pump and expanding-engine, for the purpose of showing more clearly their internal structure and arrangements. Fig. 3 is a vertical transverse section through the expanding-engine and its appendages, showing, also, the section of the reservoir. Fig. 4 is a similar section, taken through the condensing-pump. Fig. 4 $\frac{1}{2}$ is a perspective view of the vessel in which the ice is formed, removed from the refrigerating-chamber. Fig. 5 is a top view of the apparatus. Fig. 6 is a vertical longitudinal section of the machine modified in the structure and arrangement of some of its parts; and Figs. 7 and 8 are, respectively, vertical transverse sections of the same through the expanding-engine and condensing-pump.

The same letters indicate the same parts in all the figures.

It is a well-known law of nature that the condensation of air by compression is accompanied by the development of heat, while the absorption of heat from surrounding bodies, or the manifestation of the sensible effect, commonly called "cold," uniformly attends the expansion of air, and this is particularly marked when it is liberated from compression.

The nature of my invention consists in taking advantage of this law to convert water into ice artificially by absorbing its heat of liquefaction with expanding air. To obtain this effect in the most advantageous manner it is necessary to compress atmospheric air into a reservoir by means of a force-pump to one-eighth, one-tenth, or other convenient and suitable proportion of its ordinary volume. The power thus consumed in condensing the air is, to a considerable extent, recovered at the same time that the desired frigorific effect is produced by allowing the air to act with its

expansive force upon the piston of an engine, which, by a connection with a beam or other contrivance common to both, helps to work the condensing-pump. This engine is constructed and arranged in the manner of a high-pressure steam-engine having cut-offs and working the steam expansively. When the air, cooled by its expansion, escapes from the engine, it is made to pass round a vessel containing the water to be converted into ice, or through a pipe for effecting refrigeration otherwise, the air while expanding in the engine being supplied with an uncongaleable liquid whose heat it will absorb, and which can in turn be used to absorb heat from water to be congealed. By this arrangement I accomplish my object with the least possible expenditure of mechanical force, and produce artificial refrigeration in greater quantity from atmospheric air than can be done by any known means.

The apparatus for producing the refrigeratory effects before stated consists, essentially, of a large double-acting force-pump, A, with its jet-pump D, Figs. 1 and 4, condensing-tub R, and worm P, as represented in the drawing No. 4, a reservoir, B, made of such metal in the manner of a steam-boiler, a double-acting expanding-engine, C, provided with cut-offs, a jet-pump, E, a tub, I, and worm H, for cooling water, the engine C and the chamber G above it being inclosed in an insulating-box, F, which box, together with the worm and tub H, are inclosed in a second insulating room or chamber, K. The pumps, engine, and other moving parts are provided with the necessary mechanical appliances for putting and keeping them in motion and connecting them with the prime mover, which may be either a steam-engine or other available power.

It is believed that the precise nature of my invention and discovery, and the manner in which the refrigerating effects are produced, can be more clearly and fully set forth by describing the construction and operation of the apparatus in connection. I shall therefore adopt that plan in the remainder of the specification.

In the apparatus represented in Figs. 1, 2, 3, 4, and 5 the piston-rods of the pump A and engine C are attached to cross-heads *d d*, which are connected by rods *c c c c* with the cranks

$f' f'$ of a revolving shaft, b . This main shaft b is divided into two parts, which are connected by the flanges e , secured to their adjacent ends and bolted together in such a manner that the cranks on that section of the shaft which drives the pump may be placed at any angle of inclination to those which are attached to the opposite section of the shaft and worked by the engine. This angle of inclination should be such that the maximum force of the engine C may be exerted about the same time that the maximum resistance is offered by the pump A —or, in other words, that the engine, supposing that it works under a tension of eight atmospheres, may commence its stroke about the same time that the pump has completed six-sevenths of its stroke. The power of the prime mover is applied to the crank f by a connecting-rod, m , Fig. 1, and the motion is regulated by fly-wheels $r r$.

The pump A is constructed like the ordinary double-acting force-pump for air or water. It receives atmospheric air through valves $N N$, placed in its opposite ends, which open inward, and after compressing it to the degree required forces it through the eduction-valves $o o$, which open outward into a pipe, P , through which it passes into the reservoir B . A part of the pipe P is bent into a worm, which is immersed in a tub of cold water, R , to cool the air as it passes through the same.

Air, while being compressed, evolves sensible heat, which, if not absorbed or extinguished as fast as given out, will increase its elastic force greatly beyond what is due to the degree of its compression, thus requiring a greater degree of mechanical power than is absolutely necessary to compress it in the reservoir. To obviate this difficulty as far as practicable, I immerse the pump in a cistern of cold water and inject into its interior a jet of water, also cold, and in a finely-divided or other state, by means of a small pump, D , which bears a suitable relation in its size to the pump A , being in the machine I have built in the proportion I have represented in the drawings, and capable of discharging twenty-eight cubic inches of water for every cubic foot of air compressed by the latter. The pump D is double-acting, receives its motion from the eccentric h on the shaft b , and forces the water through tubes and perforated plates inserted in the lids of the pump A , into the body of air in the cylinder A . This pump D is so constructed and arranged as to force the jet into the pump A at the beginning, and continue it to the end of the stroke of its piston, so as to meet and absorb the heat as fast as evolved.

It is contemplated, particularly when the apparatus is made upon a large scale, to return the water of injection through the pump D under the pressure of the air in the reservoir, so as to recover some of the power consumed in making the injection, and also to supersede the necessity of employing a greater quantity of water than is required to insure a

proper temperature. In this use of the injection-water it is obvious that the valves of the pump D cannot be self-acting, but must be operated mechanically. Air, being a bad conductor of heat, cools very slowly when in large masses, and as it is essential to the success of this process that most of the heat set free from the air by compression should be absorbed as soon as possible after it is given out, and as the immersion of the cylinder and the injection of the jet of cold water have proved inadequate to effect this result, I have super-added a worm, P , immersed in a tub of water, R , through which the air in its transit from the pump A to the reservoir B must pass, and this effectually absorbs the remainder of the heat.

Instead of the worm, some other form of refrigerating apparatus may be used.

The reservoir B is made of twenty or thirty times the capacity of the condensing-pump A , and is provided with a stop-cock, S , inserted into its under side, through which the water of the injection, precipitated from the air, may be discharged. It is also furnished with a gage for measuring with precision the pressure of the air within it. This consists of a glass tube, closed at the upper end, filled with dry atmospheric air, inserted into and in communication with the air in the reservoir through the intervention of a cup of mercury.

The engine C is supplied with the condensed air, which works it from the reservoir B through the pipe T . Its valves V are so arranged as to cut off the supply of dense air from the reservoir when the cylinder has received a quantity which is equal to the quantity condensed by one stroke of the pump A . This air received into the engine tends to dilate with a force corresponding to the degree of its compression, which force acts alternately upon the opposite sides of the piston, communicating to it a reciprocating motion which aids in working the condensing-pump, and thus a part of the force expended in condensing the air is here reclaimed.

The refrigeratory effects of air dilating from the removal of pressure can be rendered available to the fullest extent only when the expansion is gradual, because time is required to enable it to absorb heat, and therefore the employment of the compressed air as a mechanic agent retards its expansion sufficiently to allow it to absorb the greatest amount of heat from the liquid of the jet and the walls of the cylinder, thus being an advantage to the freezing process.

The jet for the engine C is furnished by the pump E . The capacity of this pump bears the same relation to that of the engine that the pump D does to the pump A . It is arranged and operated in precisely the same manner as the pump D , except that its supply of liquid is obtained through the pipes X from the cistern W , into which, after it has performed the office of intermixture with the expanding air in the cylinder; it is returned

through the eduction-valves Z. As the temperature of the engine C, the cistern which surrounds it, and the expanding air must be kept considerably below the freezing-point of water to make ice advantageously, it follows that the liquid which fills the cistern W must be uncongealable at the low temperature at which this portion of the apparatus is required to be kept. As the waste of this liquid in a properly-constructed machine is only that which arises from evaporation, and as this latter is small at the low temperature maintained, its first cost is not a consideration of much importance, so that any liquid uncongealable at the low temperature required may be employed—as proof-spirit a solution of common salt, or of the nitrate or carbonate of potash, &c. As the air when expanded in the engine C is at a much lower temperature than that at which it is received into the pump A, and as its volume is directly as its temperature, it follows that the capacity of the engine C must be less than that of the pump A, in order that the engine may be filled with air fully expanded at a tension not less than the atmospheric, or that it may not be consumed faster than it is compressed into the reservoir. The difference between the capacity of the pump A and the engine C should be directly proportioned to the intensity of cold required to be produced, and hence the mechanical force applied by the engine will in all cases be less than that consumed by the pump, in the proportion that the heat of the air escaping from the engine is less than that entering the pump. This excess in the consumption of force by the pump over its production by the engine, together with the amount of force necessary to keep the other parts of the apparatus in motion, must be supplied, as already mentioned, from some extraneous source. The air, after its expansion in the cylinder C, passes out intimately mixed with the liquid of injection at the eduction-valves Z, and through tubes connected therewith into the cistern W, which is filled with fluid nearly to the top of the vessels J, containing the water to be converted into ice. In this way the mass of fluid in the cistern is constantly having its heat absorbed by the expanding air and cooled fluid of the jet, while at the same time it is constantly absorbing the heat of liquefaction from the water in the vessels J, which is thereby congealed. It will thus be seen that the uncongealable liquid of the cistern W merely acts as a medium to transmit the heat of the water to be congealed to the expanding air in the engine.

Experience has shown that if the vessels J be filled with water previous to the commencement of the process of refrigeration, the operation will be greatly retarded by the formation of an insulating coating of ice on its surface and on the interior of the sides and bottom of the vessels. This difficulty has, however, been obviated by furnishing the water in a small stream, and only as fast as it is frozen, by means

of a flexible tube, *t*, from the cistern I. The congelation is further hastened by rocking or jarring the vessels slightly by connecting them with some of the moving parts of the machinery. Ice is specifically lighter than water, and will therefore float on it; hence it follows that if water be admitted into the vessels J so gradually as to be frozen in films, as every film is formed it must be displaced by a film of water, which, in virtue of its superior gravity, passes under it, to be in like manner frozen to the under side of the first film of ice, and thus by successive increments of ice formed in this manner a solid block filling the vessel J may be produced. By widening the vessel J from the bottom upward the removal of the block of ice is not only rendered more easy, but the formation of it is assisted. The smaller part of the block, by gradually ascending into the larger part of the vessel, keeps a passage open around it, through which the water to be frozen runs down to the bottom. In this manner the important advantage is gained of freezing water from its under surface instead of its upper, thereby exposing every particle of it to the frigorific action of the cistern-liquid without subjecting it to the intervention of an insulating coating of ice.

To further facilitate the removal of the ice from the vessels J, they are not only made a little smaller at the bottom than at the top, but are lubricated with a thin coating of oil or grease by means of a sponge.

The cover of the refrigerating-chamber G is removable for the purpose of introducing and withdrawing the freezing-vessels J, which are suffered to remain in it such length of time as experience may determine is most advantageous. These vessels should be made of good conductors of heat, and may be of any suitable and convenient size.

In order that the capacity of the expanded air for the absorption of heat may be rendered more fully available, and also for the purpose of more effectually separating from it the liquid of the jet, it is conducted from the chamber G through the pipe H, which is bent into the form of a worm and surrounded by water in the tub I. The air in its passage through this pipe deprives the water in the tub of a portion of its heat, and as this cistern-water is the source of supply for the freezing-vessels J, its incidental refrigeration by the escaping air is so much gain to the process.

In the modified form of the apparatus (represented in Figs. 6, 7, and 8) the force-pump A and expanding-engine C are connected with the opposite ends of a lever-beam, M, by means of links, jointed to their respective piston-rods L and U. This connection insures uniformity of action between the pump and engine, and enables the latter to act directly upon the pump, to aid in working it. As an inspection of the drawing of this modified arrangement will render it fully understood, if made in connection with the description of the process as performed by the machine, (repre-

sented in Figs. 1, 2, 3, 4, and 5,) I have deemed an explanation of the same in detail to be unnecessary.

The several parts of the foregoing apparatus may be made of such materials as it may be deemed advisable by the constructor to employ in reference to the efficiency of the machine, economy in its cost, or other considerations that may influence him, and the form and arrangement of the several parts may be varied indefinitely without essentially changing the character of the invention.

It will have been seen that a great object aimed at in the construction of the machine is as perfect a system of compensations (chemical and mechanical) as possible. Thus the heat evolved and carried off in the condensation of air is replaced in the expanding-engine by an abstraction of heat from the water to be frozen through the intervention of the liquid in the cistern. In the consumption and production of mechanical force these compensating equivalents are more general and more marked. It has already been intimated that the power consumed in compressing air is nearly all recovered in the force exerted by its subsequent dilatation, and it has been shown in what way the force required to inject the water for receiving the heat of the condensed air may be, in a great measure, derived from the pressure of the air in the reservoir. It is evident that a mechanical apparatus admitting of such a system of compensations must operate, in theory at least, without the consumption of any power other than that required to overcome its friction, and to supply the loss arising from the difference of temperature, and consequently of bulk, between the air as it exists before condensation and after expansion; and, practically, the working of the machine is found not to differ materially from this result, and thus it presents by far the most comprehensive application of natural laws to the economical produc-

tion of cold that it is believed has ever been devised.

Having thus fully made known my improved process of manufacturing ice and explained and exemplified suitable machinery for carrying the same practically into operation, I wish it to be understood that I do not claim as my invention any of the several parts of the apparatus in themselves; but

What I do claim as my invention, and desire to secure by Letters Patent, is—

1. The employment of a liquid uncongealable at the low temperature at which it is required to keep the engine, to receive the heat of the water to be congealed and give it out to the expanding air.

2. The employment of an engine for the purpose of rendering the expansion of the condensed air gradual, in order to obtain its full refrigeratory effects, and at the same time render available the mechanical force with which it tends to dilate, to aid in working the condensing-pump irrespective of the manner in which these several parts are made, arranged, and operated.

3. Supplying the water gradually and slowly to the freezing-vessels and congealing it by abstracting the heat from its under surface, substantially as herein set forth.

4. The process of cooling or freezing liquids by compressing air into a reservoir, abstracting the heat evolved in the compression by means of a jet of water, allowing the compressed air to expand in an engine surrounded by a cistern of an unfreezable liquid, which is continually injected into the engine and returned to the cistern, and which serves as a medium to absorb the heat from the liquid to be cooled or frozen and give it out to the expanding air.

JOHN GORRIE.

Witnesses:

JOHN G. RUAN,
J. R. POTTS.