



US 20160207625A1

(19) **United States**

(12) **Patent Application Publication**  
**JUDAS et al.**

(10) **Pub. No.: US 2016/0207625 A1**

(43) **Pub. Date: Jul. 21, 2016**

(54) **AIRCRAFT CAPABLE OF VERTICAL TAKE-OFF**

*B64C 3/38* (2006.01)

*B64C 5/08* (2006.01)

*B64D 27/02* (2006.01)

(71) Applicants: **Airbus Defence and Space GmbH**,  
Ottobrunn (DE); **STEUBBEUS  
FLUGZEUG- UND LEICHTBAU  
GMBH**, Stuttgart (DE)

*B64D 27/24* (2006.01)

*B64C 39/02* (2006.01)

*B64C 39/08* (2006.01)

(52) **U.S. Cl.**

CPC ..... *B64C 29/0025* (2013.01); *B64C 39/024*

(2013.01); *B64C 27/08* (2013.01); *B64C*

*27/473* (2013.01); *B64C 39/08* (2013.01);

*B64C 5/08* (2013.01); *B64D 27/02* (2013.01);

*B64D 27/24* (2013.01); *B64C 3/38* (2013.01);

*B64C 2201/108* (2013.01); *B64C 2201/104*

(2013.01); *B64C 2201/165* (2013.01); *B64D*

*2027/026* (2013.01)

(72) Inventors: **Michael JUDAS**, Muenchen (DE);  
**Friederike STRATENBERG**,  
Ingolstadt (DE); **Jan VAN TOOR**,  
Muenchen (DE); **Werner SCHOLZ**,  
Ohmden (DE); **Berthold KARRAIS**,  
Epfendorf (DE); **Wolfgang STANGL**,  
Muenchen (DE)

(73) Assignee: **Airbus Defence and Space GmbH**,  
Ottobrunn (DE)

(57) **ABSTRACT**

The invention relates to an aircraft which can both take off and land vertically and can hover and also fly horizontally at a high cruising speed. The aircraft has a support structure, a wing structure, at least three and preferably at least four lifting rotors and at least one thrust drive. The wing structure is designed to generate a lifting force for the aircraft during horizontal motion. To achieve this the wing structure has at least one mainplane provided with a profile that generates dynamic lift. The wing structure is preferably designed as a tandem wing structure. Each of the lifting rotors is fixed to the support structure, has a propeller and is designed to generate a lifting force for the aircraft by means of a rotation of the propeller, said force acting in a vertical direction. The thrust drive is designed to generate a thrust force on the support structure, said force acting in a horizontal direction. The lifting rotors can have a simple construction, i.e. they can have a simple rigid propeller for example, and a vertical take-off or hovering of the aircraft can be controlled, in a similar manner to quadcopters, by a simple control of the speeds of the lifting rotors. High cruising speeds can be achieved as a result of the additional horizontally acting thrust drive.

(21) Appl. No.: **14/915,101**

(22) PCT Filed: **Aug. 29, 2014**

(86) PCT No.: **PCT/EP2014/068410**

§ 371 (c)(1),

(2) Date: **Feb. 26, 2016**

(30) **Foreign Application Priority Data**

Aug. 29, 2013 (DE) ..... 10 2013 109 392.2

**Publication Classification**

(51) **Int. Cl.**

*B64C 29/00* (2006.01)

*B64C 27/08* (2006.01)

*B64C 27/473* (2006.01)

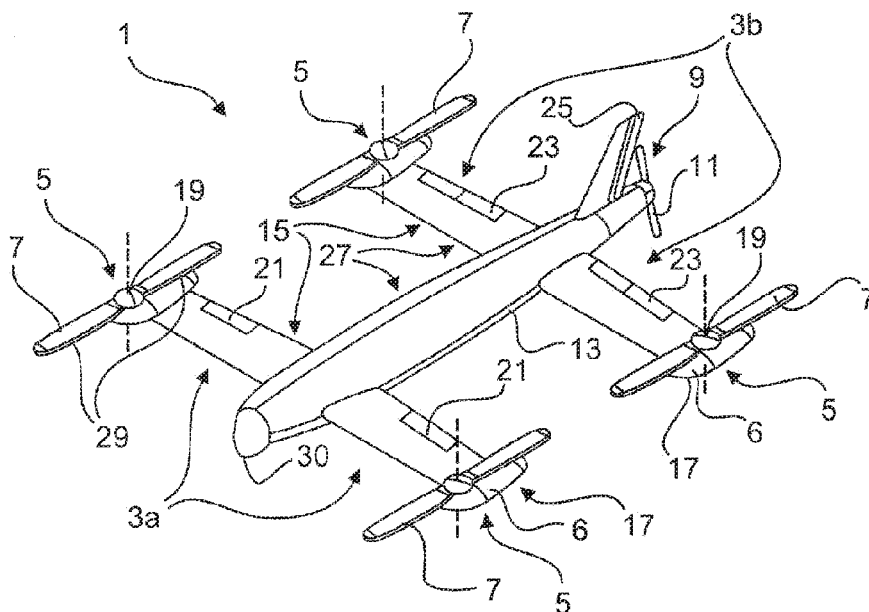

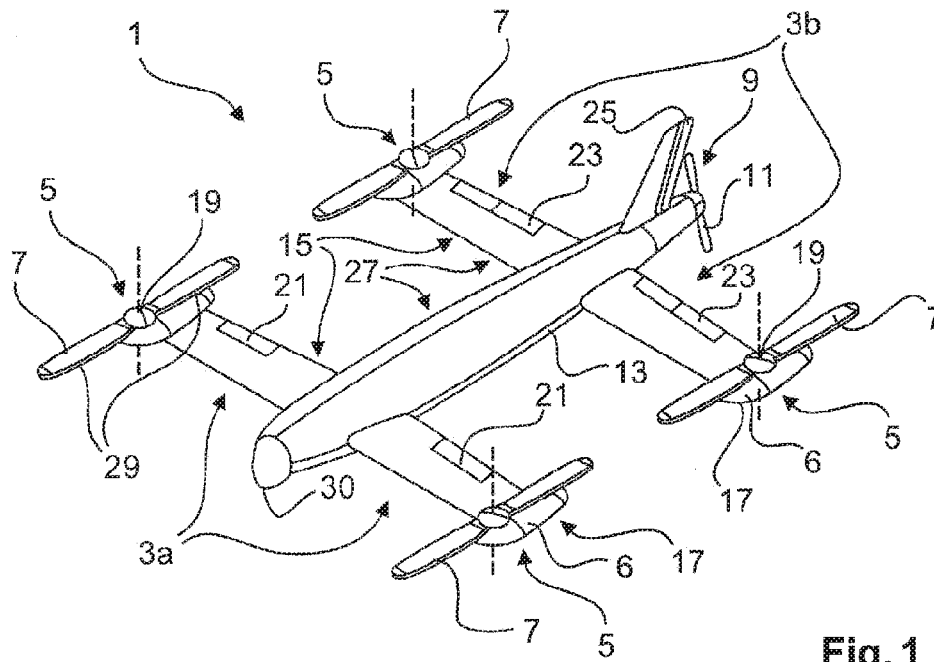

Fig. 1

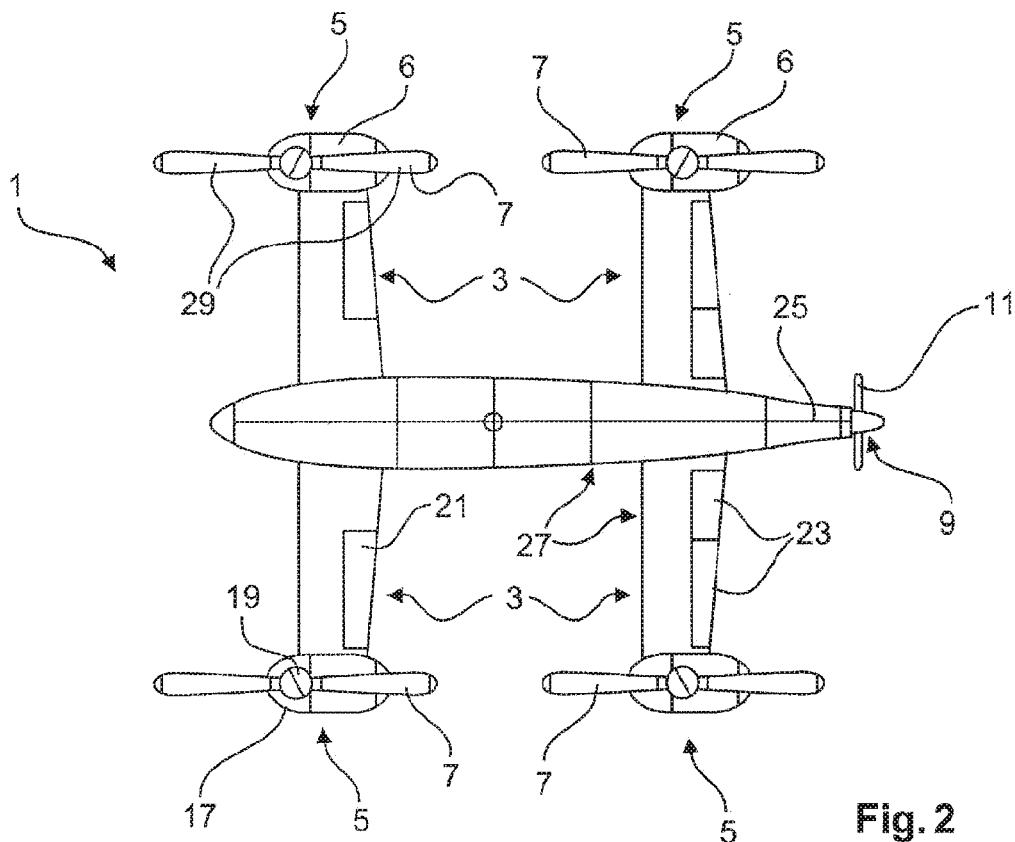

Fig. 2

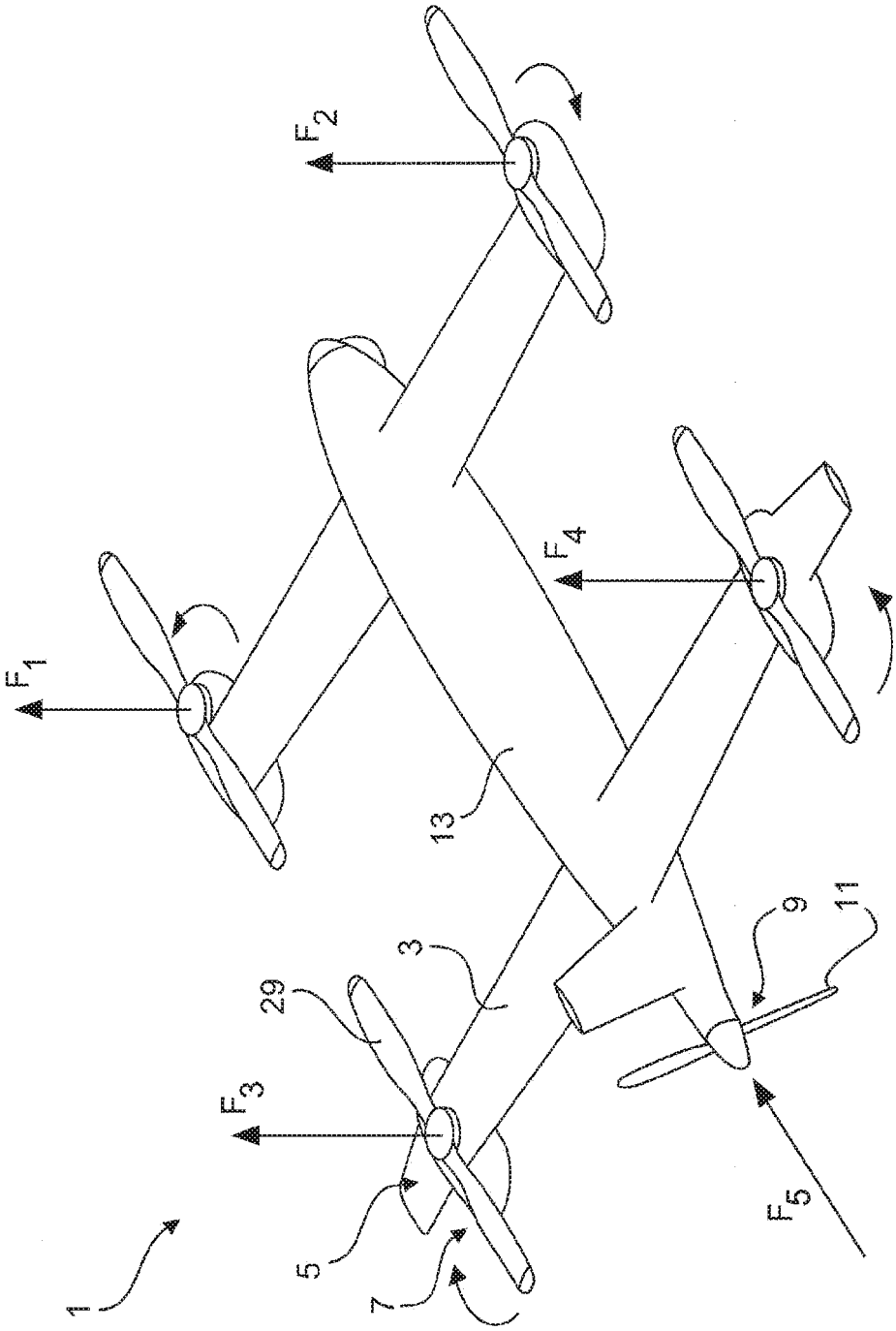

Fig. 3

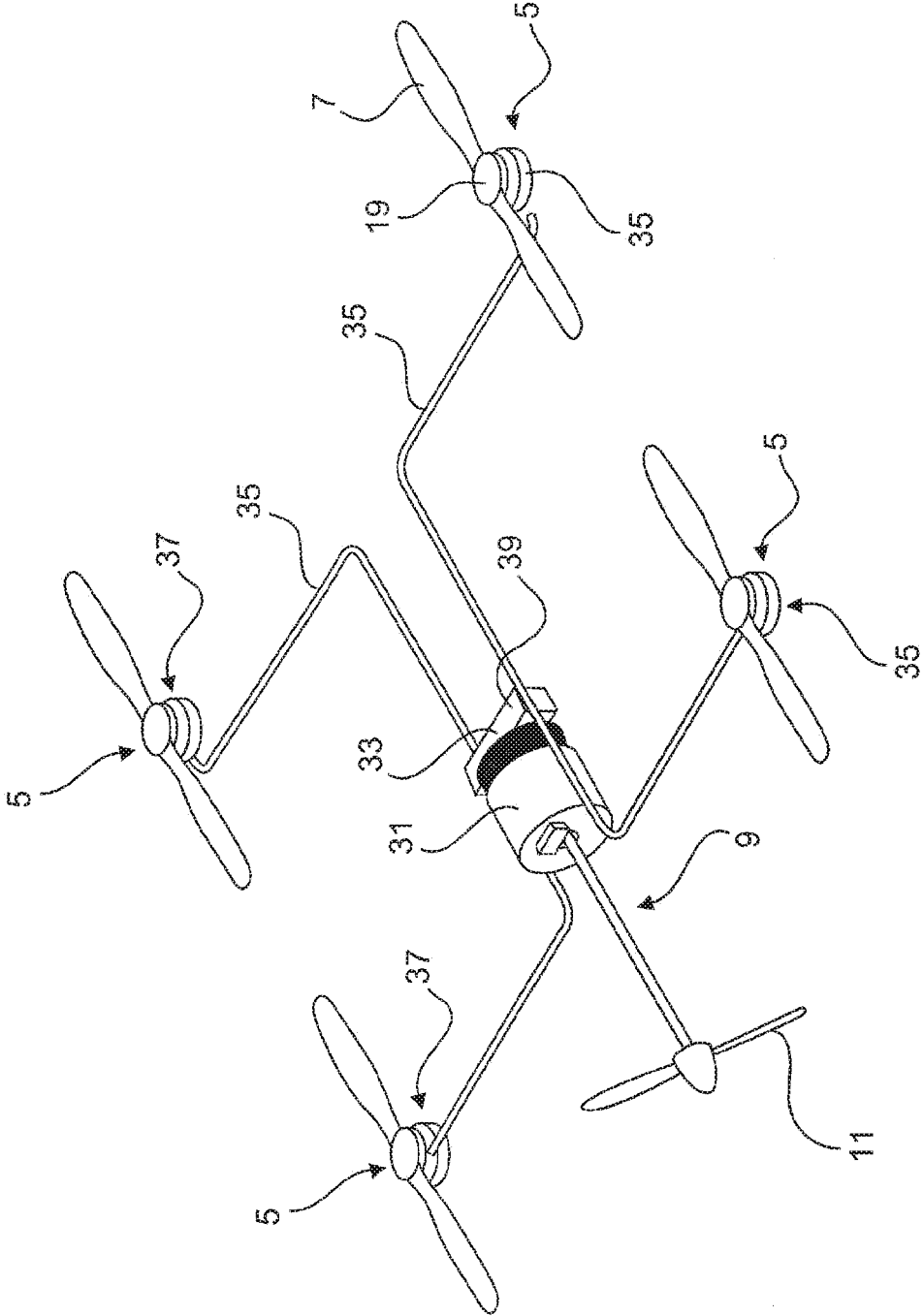

Fig.4

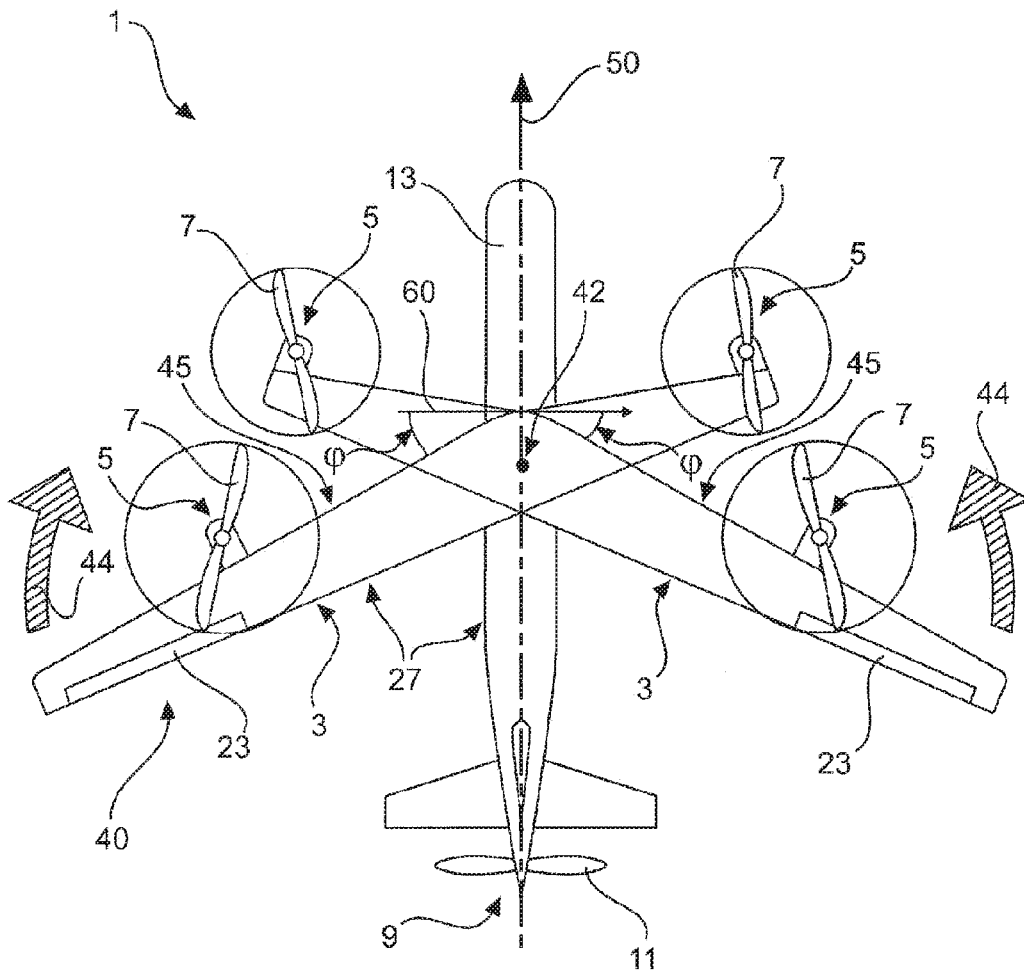

Fig. 5

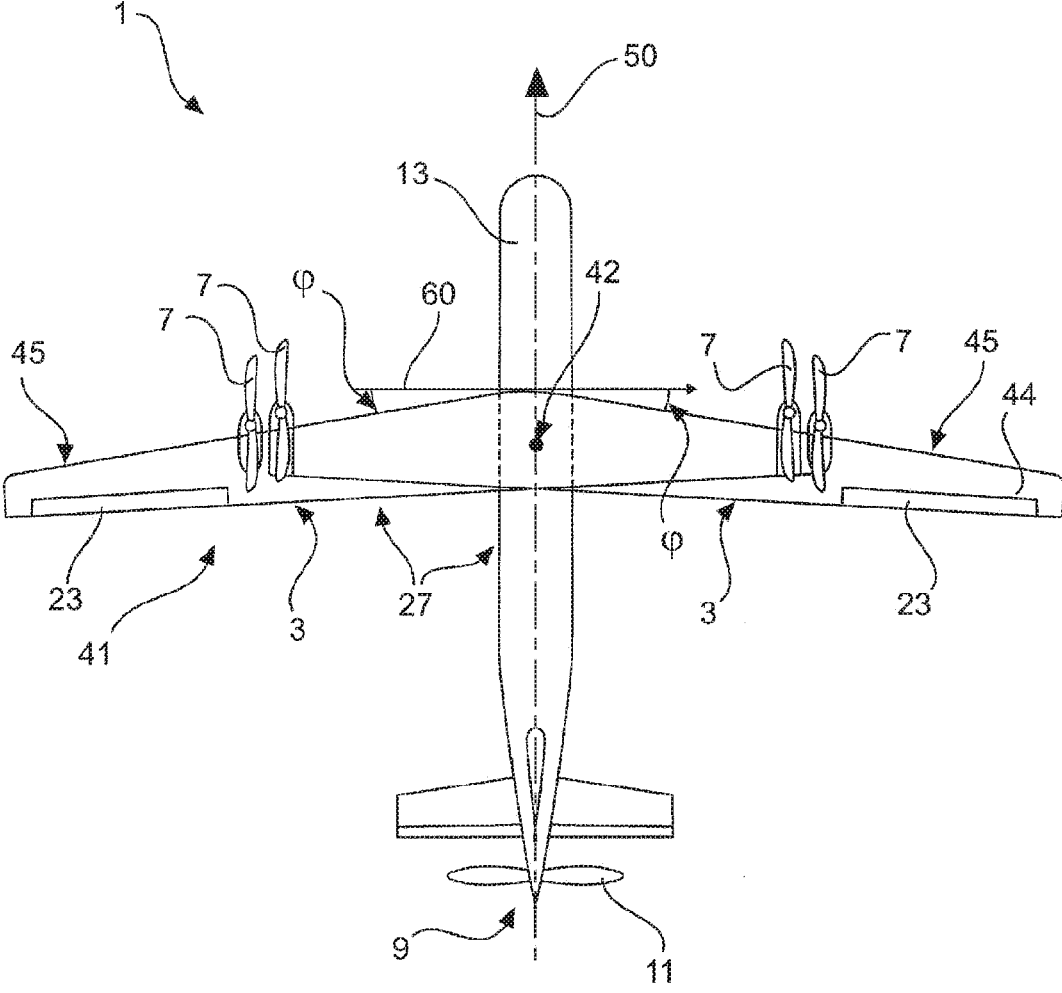

Fig. 6



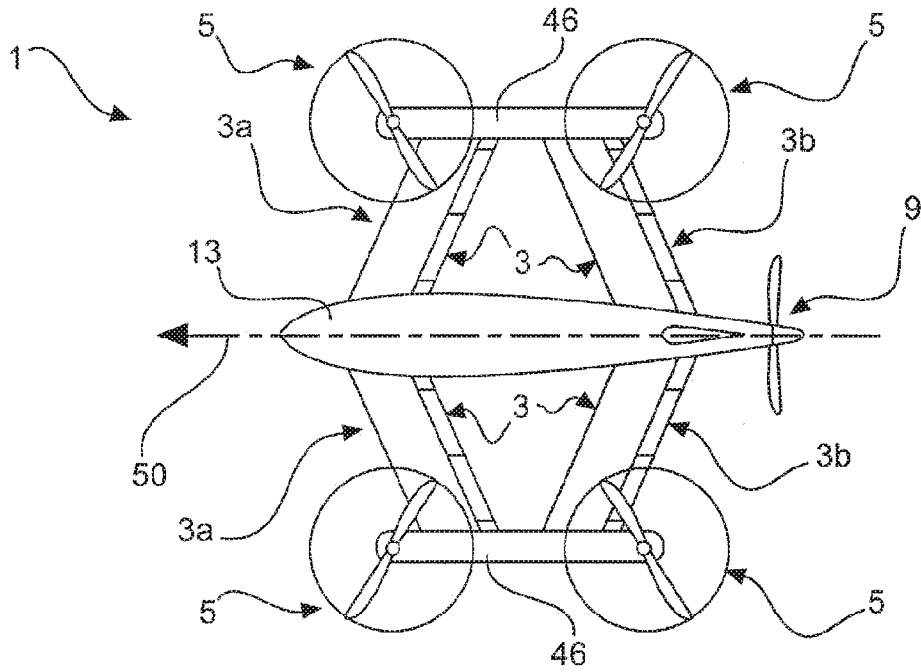

Fig. 8

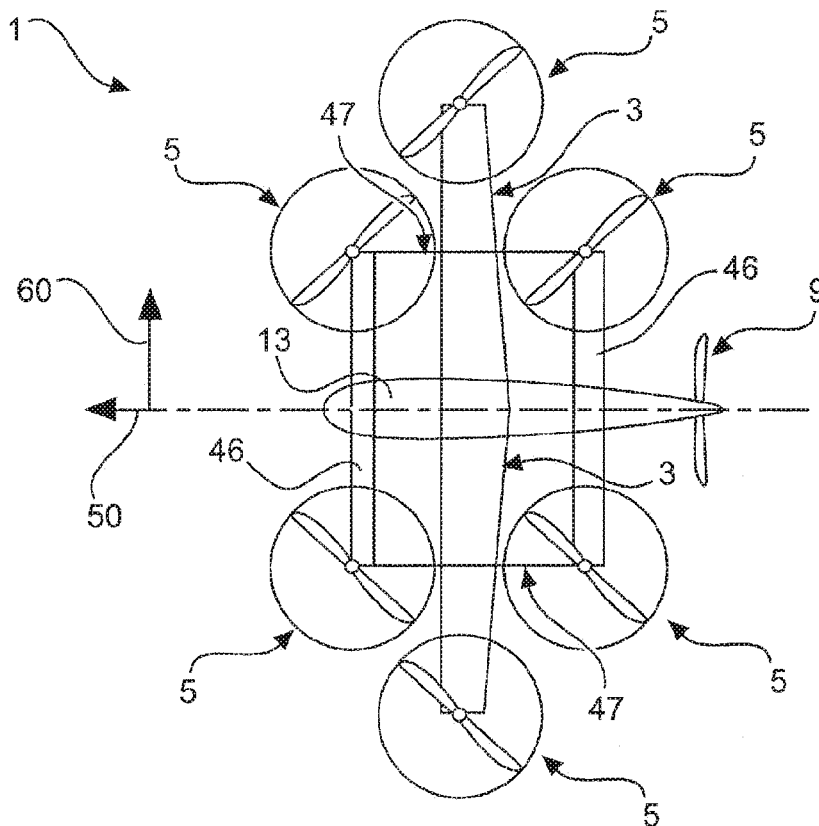

Fig. 9



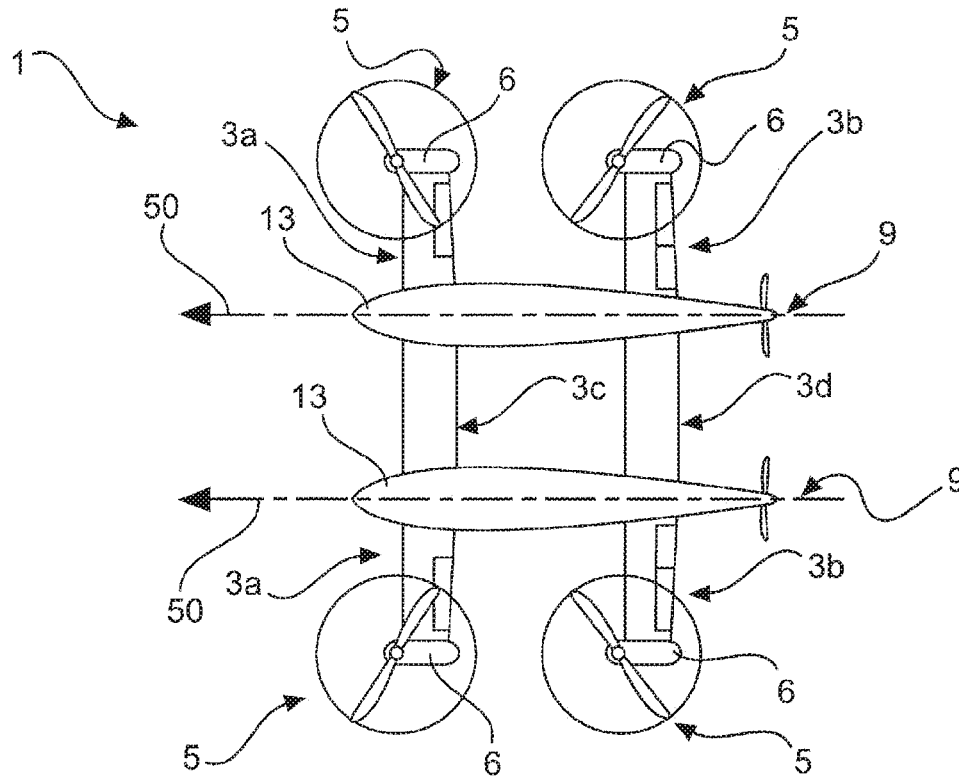

Fig. 10

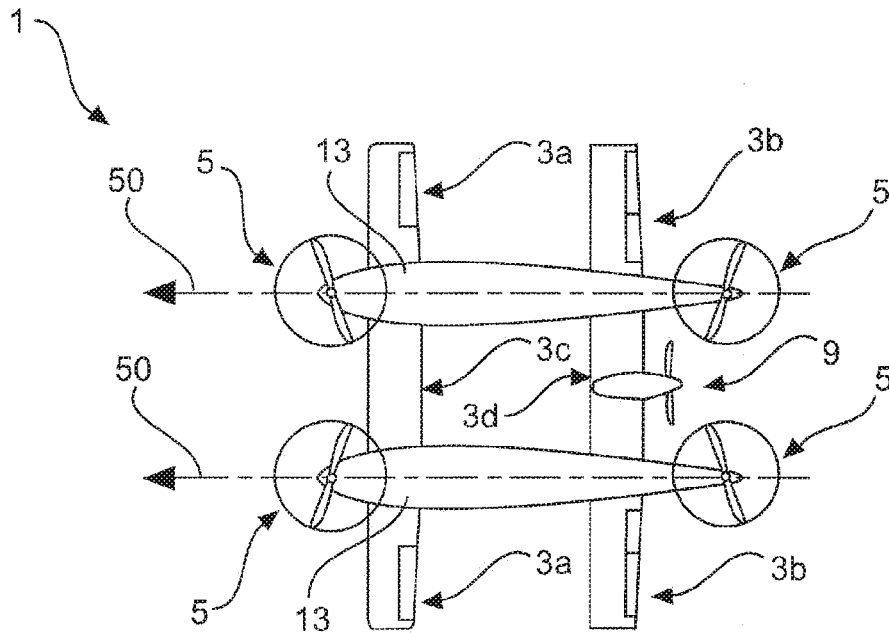

Fig. 11

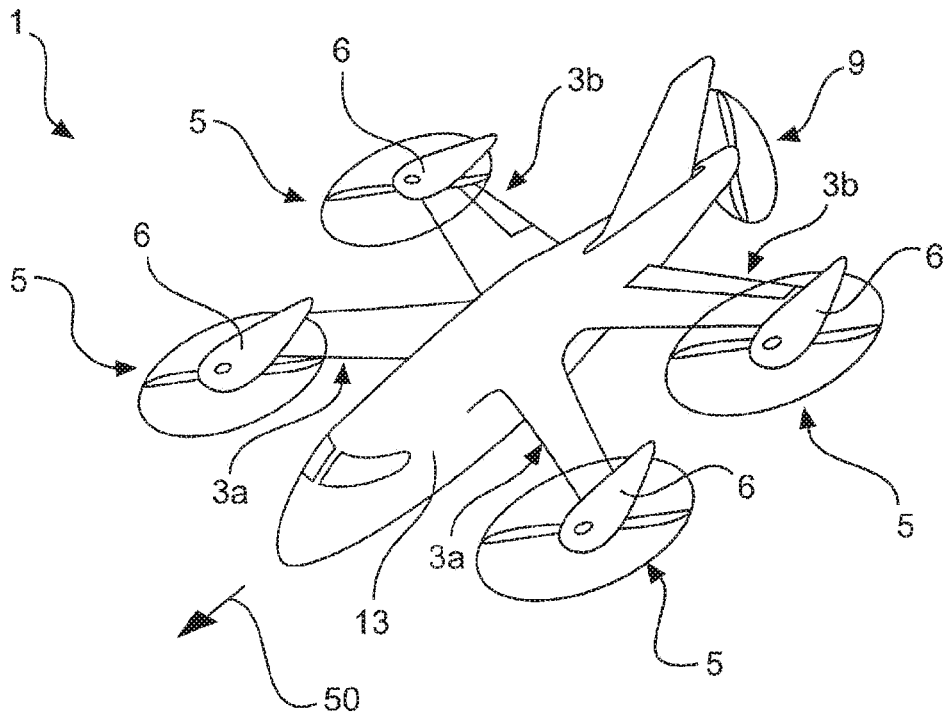

Fig. 12

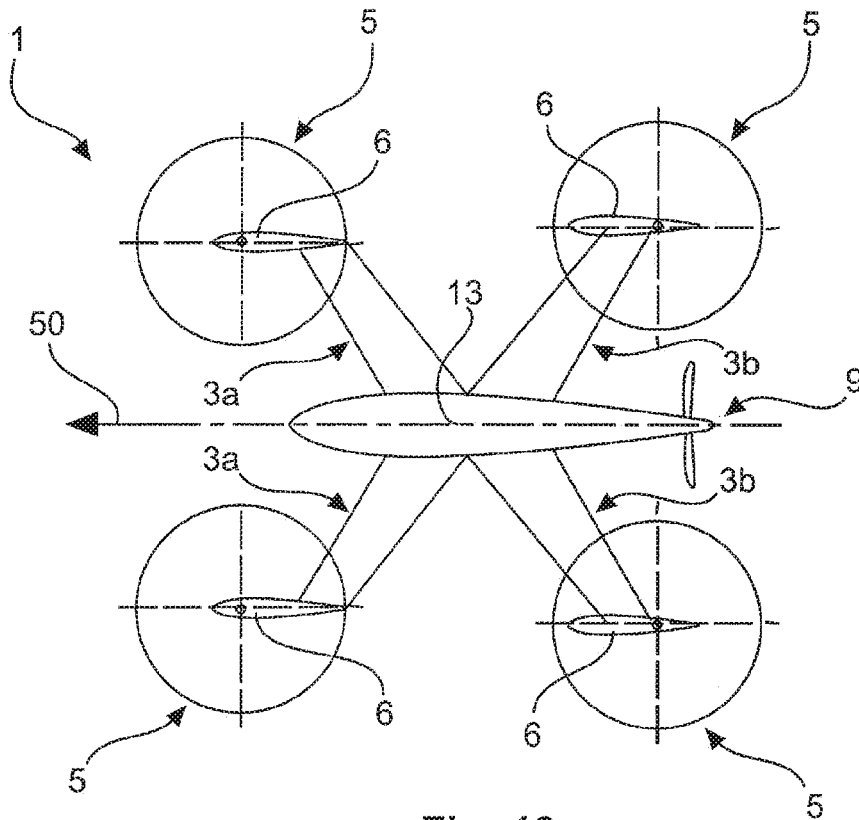

Fig. 13

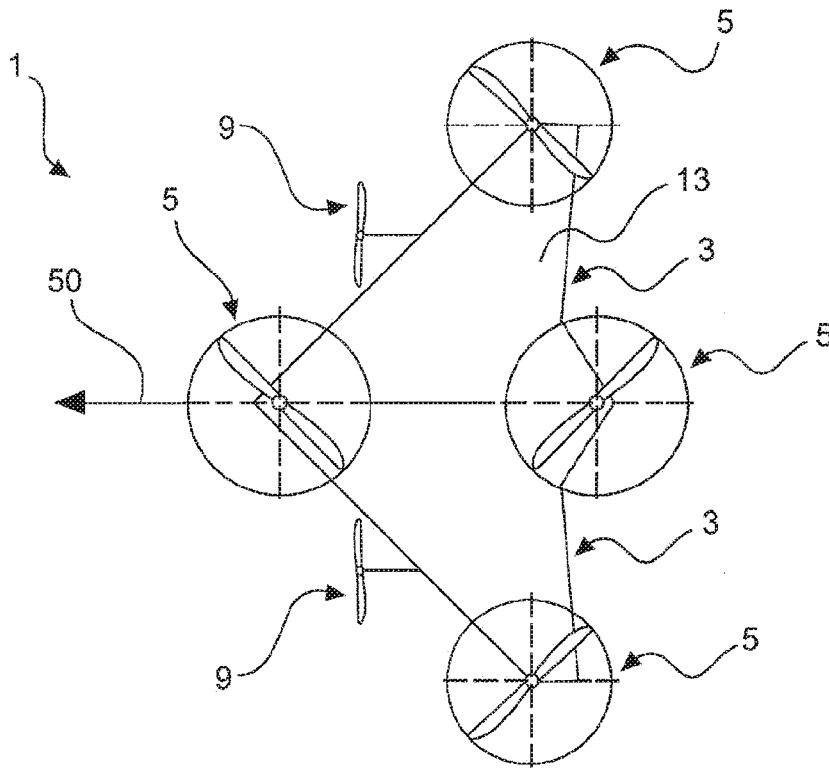

Fig. 14

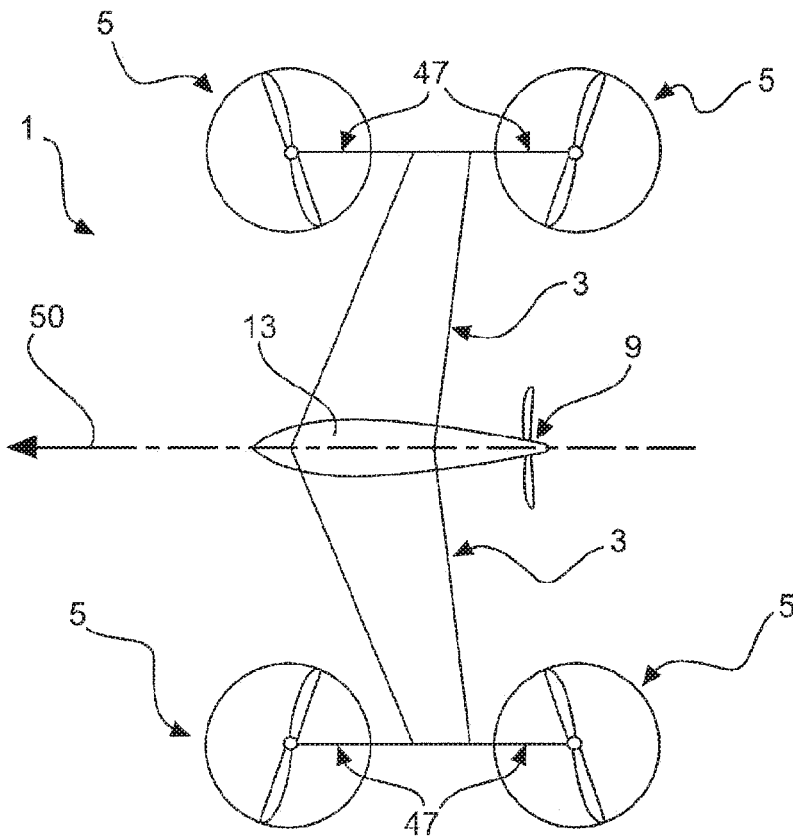

Fig. 15

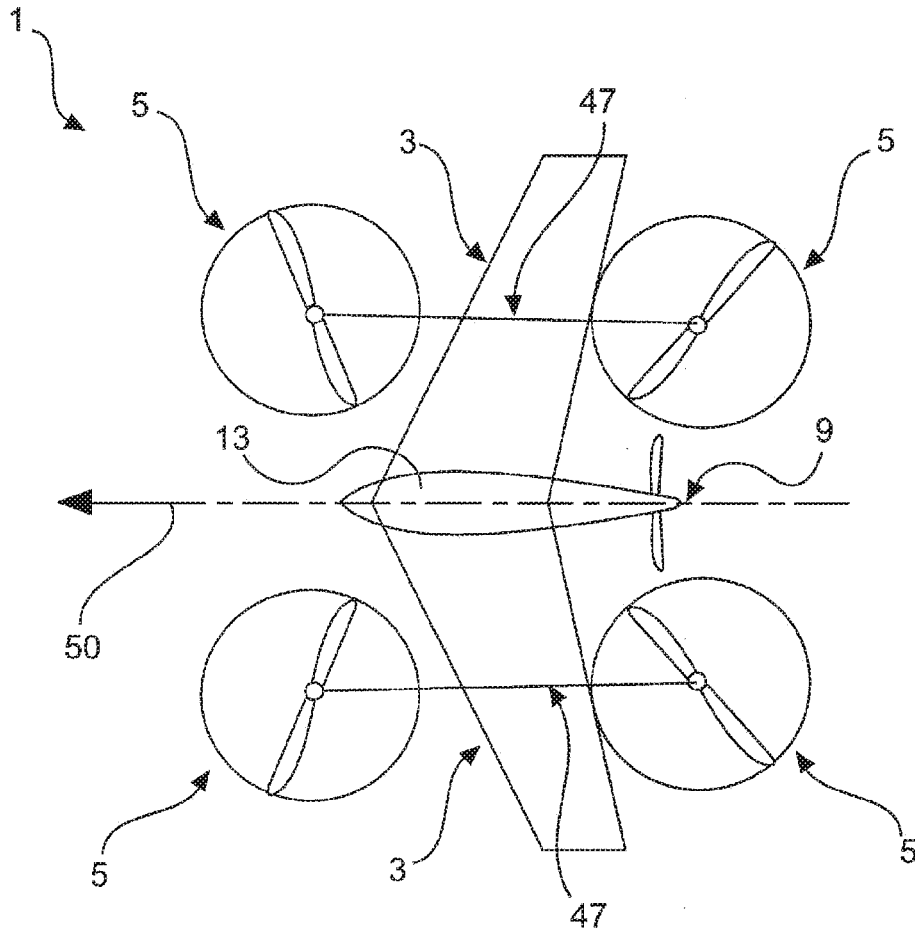

Fig. 16

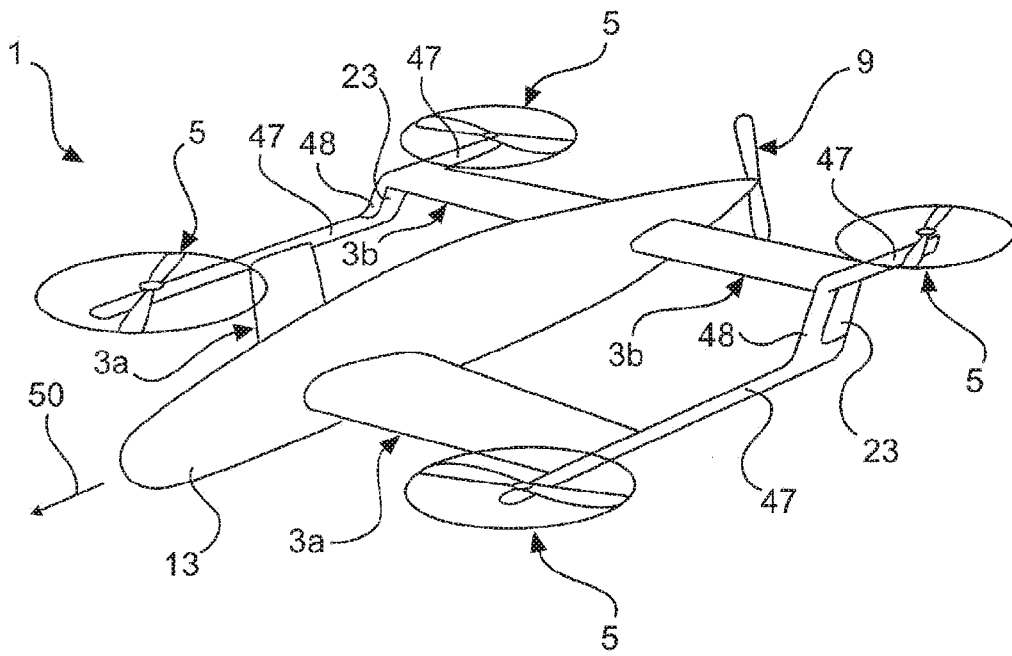

Fig. 17

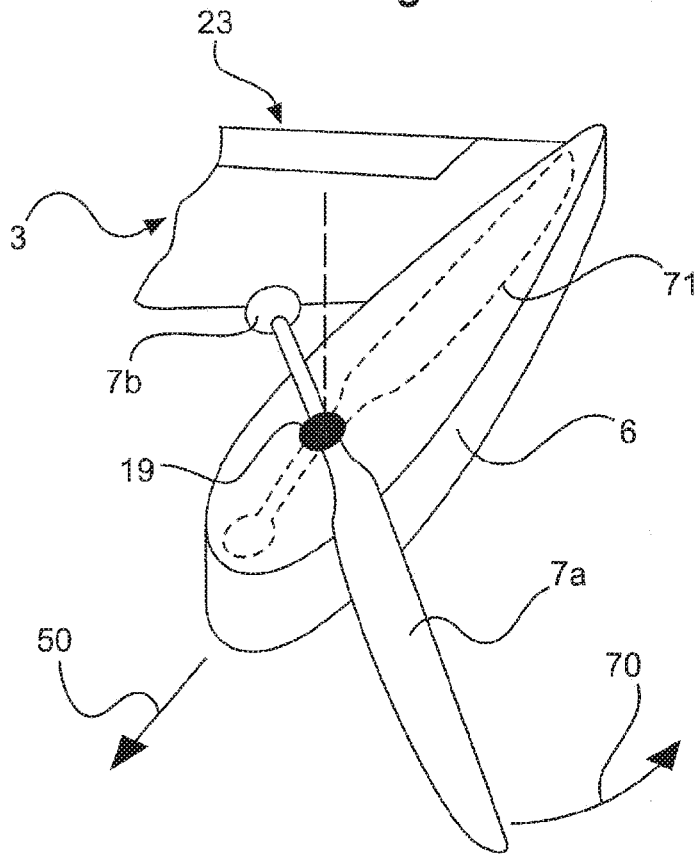

Fig. 18

## AIRCRAFT CAPABLE OF VERTICAL TAKE-OFF

### CROSS REFERENCE TO RELATED APPLICATIONS

**[0001]** The present application is a National Stage of International Application No. PCT/EP2014/068410, filed Aug. 29, 2014, which claims the priority of German patent application No. 10 2013 109 392.2, filed on 29 Aug. 2013, the entire disclosures of which is hereby incorporated by reference.

### FIELD OF THE INVENTION

**[0002]** The present invention relates to an aircraft capable of vertical take-off, for example similar to a tricopter or a quadcopter.

### BACKGROUND OF THE INVENTION

**[0003]** For many uses, it is desirable to have available an aircraft which can take-off from a very small surface and which therefore does not require a specific large airport for example. Furthermore, for particular purposes of use, an aircraft is required which is agile, which can be maneuvered precisely and which can preferably hover on the spot and, in this respect, can have good hover flight characteristics.

**[0004]** For example, aircraft are used for aerial surveillance and aerial reconnaissance, which aircraft hover above an object of interest and while so doing are able to record aerial images, for example. In an alternative use, an aircraft capable of vertical take-off, sometimes also called VTOL (vertical take-off and landing), can be used to approach territories which cannot be easily accessed by people or miscellaneous machines, for example as part of a disaster management intervention, to be able to transport goods, such as tools, food or medicines, into such territories.

**[0005]** Aircraft have been developed for such uses, inter alia, in which at least three, preferably four or more rotors fitted with a propeller and a motor driving said propeller respectively provide a substantially vertically upwardly directed thrust to thereby allow the aircraft to be able to take off vertically or to hover. An aircraft provided with four rotors of this type is also known as a quadcopter, quadrocopter, quadricopter, quadrotor or hover platform. Aircraft of this type having more than three thrust-providing rotors are generally known as multicopters and, in addition to quadcopters, variants with three rotors (tricopters), six rotors (hexacopters) or eight rotors (octocopters) are also common. Aircraft of this type are generally operated unmanned and thus can be small. These aircraft are sometimes also called drones.

**[0006]** By slightly inclining the entire aircraft or one or more rotors out of the horizontal, it is possible in aircraft of this type to also provide a particular propulsion in which a thrust generated by the rotors is inclined out of the vertical. However, cruising speeds which are achievable in this manner are restricted to relatively low speeds of typically less than 200 km/h, often even less than 100 km/h, due to physical boundary conditions which arise in this type of aircraft. A speed restriction of this type results, for example from the physical boundary condition that the propellers used for lift are operated at high rotational speeds, and therefore a propeller blade moving forwards in the direction of flight of the aircraft must move almost at sonic speed at least at the tips of

the propeller blade even at relatively low cruising speeds, as a result of which a high air resistance and a loud noise are generated.

**[0007]** Therefore, although conventional multicopters have good hover characteristics like helicopters in which only a single rotor provides the necessary lift and complicated rotor mechanics can be used together with a tail rotor for maneuvering the helicopter, they usually only achieve relatively low cruising speeds.

**[0008]** KR 10 2012 006 05 90 A discloses a quadrocopter which can take off and land vertically and in which a thrust direction can be varied by propellers to be able to provide not only lift, but also propulsion for the quadrocopter.

### SUMMARY OF THE INVENTION

**[0009]** It can be considered as an object of the present invention to provide an aircraft which allows both good hover characteristics and high cruising speeds.

**[0010]** According to one aspect of the present invention, an aircraft is proposed which has a support structure, a wing structure, at least three lifting rotors and at least one thrust drive. The wing structure is attached to the support structure. The wing structure can also be part of the support structure of the aircraft. The wing structure is configured to generate a lifting force for the aircraft during horizontal motion of the aircraft and for this purpose has at least one aerofoil which is provided with a profile generating dynamic lift. Each of the lifting rotors is attached to the support structure. Each lifting rotor has a propeller and is configured to generate a lifting force, acting vertically, for the aircraft by rotation of the propeller. The thrust drive is configured to generate a thrust, acting horizontally, on the support structure.

**[0011]** In short, one idea underlying the invention can be seen, inter alia, in fitting an aircraft in the form of a multicopter on the one hand with at least three lifting rotors which generate a vertical thrust, by which the aircraft can take-off and land vertically and can also hover, and also on the other hand in providing a thrust drive which can generate a horizontally acting thrust so that the aircraft can be accelerated to a high cruising speed independently of the lifting rotors after the rotors have stopped. The aircraft is also provided with a wing structure in which at least one aerofoil provides dynamic lift when the aircraft has been accelerated to a sufficiently high cruising speed.

**[0012]** The aerofoil or aerofoils of the wing structure are preferably configured such that they alone can provide adequate lift for the aircraft at cruising speeds to be achieved by the aircraft and it is thereby possible to dispense with a lift generated by the lifting rotors at cruising speed.

**[0013]** The aerofoils can be attached swivelably or rotatably, for example, to the support structure or to a fuselage so that during a hover state or while hovering, they are in a swivelled-out state and while cruising, they are in a swivelled-in state. In this respect, the swivelling-out of the aerofoils increases the sweep of the wing structure and the swivelling-in reduces the sweep. The sweep describes an angle between a leading edge of the respective aerofoil and a transverse axis of the aircraft. With regard to the direction of flight, it is possible to differentiate between negative sweep, i.e. forwardly swept aerofoils, and positive sweep, i.e. backwardly swept aerofoils. This connection will be explained in more detail in the description of the drawings.

**[0014]** Furthermore, configurations of the aircraft with three aerofoils or pairs of aerofoils can be provided. The

aerofoils can also be interconnected by connecting structures or connecting elements, as is the case for coleopters, for example. The propellers can be attached to the connecting structures or connecting elements by arms or nacelles. The propellers are preferably attached to the aerofoils, to the support structure, to arms, connecting structures, connecting elements or to nacelles.

**[0015]** An aircraft according to the invention, which is provided with a combination of at least three lifting rotors and at least one thrust drive as well as a suitably configured wing structure, can have the desired good hover characteristics and can also achieve high cruising speeds. For example, during take-off or landing or during hover flight, i.e. when there is a lack of or only slight horizontal speed of the aircraft, the lifting rotors can provide the necessary lift. Independently of the lifting rotors, the thrust drive can accelerate the aircraft in the horizontal direction and, with adequately high horizontal speeds, a dynamic lift generated by the at least one aerofoil of the wing structure can be high enough to support the aircraft.

**[0016]** The individual components of the proposed aircraft can be configured and controlled relatively simply. In particular, the lifting rotors can be configured such that a plane of rotation, in which rotor blades of a lifting rotor rotate, is stationary relative to a motor-driven shaft of the lifting rotor.

**[0017]** In other words, the lifting rotors of the aircraft can be of a simple mechanical construction and, for example, a simple propeller can be directly coupled to a motor-driven shaft. In particular, it is unnecessary to connect rotor blades of the lifting rotor to a motor-driven rotor shaft by a complicated mechanism, for example by a swash plate as in the case of a helicopter. In particular, it is unnecessary to change an angle of incidence or inclination angle of individual rotor blades during a rotor revolution in order to thus also provide propulsion of the aircraft or rolling, pitching or yawing of the aircraft. Instead, propulsion of the proposed aircraft can be achieved by the additional thrust drive. Rolling, pitching or yawing of the aircraft can be achieved by varying the lifting forces respectively generated by the usually at least four lifting rotors.

**[0018]** In a particularly simple configuration, the propeller blades of a lifting rotor can be rigidly connected to the rotor shaft. A propeller provided thus with rigid blades has no movable parts. It is thus robust and, for example, does not require any mechanism or control means to be able to control a variable arrangement of propeller blades. In particular, the propeller can be integral. The lifting force generated by a simply constructed lifting rotor of this type mainly depends on the rotation speed or speed at which the propeller is driven and can thus be simply controlled by a suitable control of the driving motor.

**[0019]** Alternatively, the lifting rotor can be more complex and propeller blades of the lifting rotor can be connected swivelably to the rotor shaft such that a pitch of the propeller blades can be varied.

**[0020]** In other words, an angle which is included by the propeller blades with the plane of rotation in which the propeller blades rotate can be varied. Varying the pitch of the propeller blades in this way can preferably be carried out for all the propeller blades together. In particular, the pitch of the propeller blades can be varied irrespective of a current position of the rotating propeller blades, i.e. the propeller blades are not varied in their pitch during a revolution, as with a swash plate in the case of a helicopter, but the pitch of the propeller blades remains substantially constant during a revolution.

This type of relatively slow variation in the pitch of the propeller blades can be realized simply and by means of a robust mechanism.

**[0021]** Varying the pitch of the propeller blades can influence the thrust of the lifting rotor and hence the lifting force generated thereby, without necessarily having to change the rotational speed of the propeller. A lifting propeller of this type provided with jointly swivelable propeller blades is also known as a variable pitch propeller.

**[0022]** In principle, it can suffice to fit the proposed aircraft with only three lifting rotors. In this respect, each of the lifting rotors should be separately controllable, i.e. it should be possible to vary a thrust generated by one of the lifting rotors independently of the other lifting rotors. The at least three lifting rotors are attached to the aircraft in positions which together clearly span a plane, i.e. the lifting rotors should not be arranged linearly in tandem along a common straight line. By appropriately controlling the three lifting rotors to generate different lifting forces, the plane spanned by the lifting rotors and thereby the entire aircraft can be tilted.

**[0023]** As long as the lifting rotors are oriented such that the sum of the thrusts which they have generated acts substantially vertically downwards, the aircraft can hover in a stationary manner and the flight altitude of the aircraft can be varied by varying the strength of this total thrust. If, starting from a hover flight of this type, the thrust generated by individual lifting rotors is changed, this can mean that the total thrust acting on the aircraft no longer acts vertically downwards. Consequently, the aircraft can tilt forwards, backwards or to one side and can gain momentum or start to roll forwards or backwards.

**[0024]** If the proposed aircraft is restricted to only three lifting rotors, it is possible to save components and thereby to reduce weight. However, in general it is difficult with only three lifting rotors to allow the aircraft to rotate about its vertical axis, i.e. to yaw.

**[0025]** Therefore, it can be advantageous to fit the proposed aircraft with at least four lifting rotors, similarly to the case of a quadcopter. The four lifting rotors can preferably be controlled independently of one another. Since the position or inclination of the aircraft can already be determined by the thrust generated by just three lifting rotors, providing an additional fourth lifting rotor presents the possibility of also allowing the aircraft to yaw. The aircraft can thus be brought into any desired position and flight direction by appropriately controlling the four lifting rotors. An aircraft of this type with four or more lifting rotors can also be maneuvered in a precise and agile manner, in addition to having good hover characteristics.

**[0026]** The proposed aircraft is to have a support structure and a wing structure. The support structure is to provide structural strength to the aircraft so that both the wing structure and the lifting rotors can be attached in a stable manner to the aircraft. The wing structure is to be able to provide dynamic lift by means of suitably configured aerofoils when the aircraft adopts a sufficiently high cruising speed.

**[0027]** It should be noted that the fact that two separate terms are used for the support structure and the wing structure does not mean that the functions to be performed by the support structure and by the wing structure do not necessarily have to be performed by separate actual structures. For example, functions of the support structure and functions of the wing structure can be performed by different structural components of the proposed aircraft or even by the same

structural components of the aircraft. As an example, a wing of an aircraft can simultaneously function as an aerofoil generating a dynamic lift and thereby as part of a wing structure and it can also mechanically interconnect other components of the aircraft and can thus function as part of a support structure. For example, the wing can have an outer skin which provides a profile of an aerofoil formed thereby and is thus part of the wing structure. At the same time, the wing can have inner components such as struts which provide a mechanical strength and to which, for example, the wing skin is attached so that these can serve as a support structure.

**[0028]** In an advantageous embodiment, the support structure together with the wing structure is configured as a tandem wing structure. Provided in a tandem wing structure of this type is at least one elongate fuselage, from which two pairs of aerofoils arranged horizontally in tandem project transversely.

**[0029]** In a tandem wing structure of this type, the fuselage together with supporting structures in the projecting pairs of aerofoils can serve as a support structure. One of the lifting rotors can be respectively arranged on each of the aerofoils. If, for example, two pairs of aerofoils are provided, the first pair of aerofoils and the second pair of aerofoils can have a different sweep. If the first pair of aerofoils has a negative sweep and the second pair of aerofoils has a positive sweep, a plan view of the aircraft can give the impression of an x-shaped arrangement of the aerofoils. Furthermore, the aspect ratio can be increased by attaching wing tip extensions to the aerofoils which have already been integrated into the support structure, thereby increasing the wingspan of the wing structure or of the pairs of aerofoils. A person skilled in aircraft construction understands "aspect ratio" as meaning the ratio of the square of wingspan of both aerofoils and of the wing area which is revealed in a plan view of the aircraft.

**[0030]** The two pairs of aerofoils of a tandem wing structure can also be arranged, for example, offset relative to one another along the vertical axis of the aircraft, i.e. in a z direction.

**[0031]** It is pointed out that a plurality of elongate fuselages can also be provided as part of a support structure. For example, two elongate fuselages are arranged next to one another parallel to the direction of flight and are interconnected by at least one further aerofoil or by a further pair of aerofoils.

**[0032]** The lifting rotors are thus arranged distributed in a planar manner over the aircraft and can thereby provide good hover characteristics. The lifting rotors can preferably be respectively arranged in end regions of the aerofoils, i.e. laterally approximately at a maximum distance from the fuselage. Furthermore, the four aerofoils of the two pairs of aerofoils arranged in tandem can respectively provide a dynamic lift at an adequate cruising speed. The aerofoils and the lifting rotors can be configured such that they produce approximately identical lifting forces in hover flight or at a desired cruising speed. The support structure of the aircraft can be suitably configured and dimensioned to be able to absorb lifting forces of this type. Accordingly, the support structure can be optimized in respect of its strength and weight.

**[0033]** A nacelle, on which respectively one of the lifting rotors is arranged, can be positioned on each of the aerofoils. For example, a motor for the rotor can be accommodated in the nacelle. The nacelle can be configured to be aerodynamically efficient with regard to a rotor-generated air flow and/or with regard to an air flow while cruising.

**[0034]** In particular, a tail unit or rudder can be arranged on each of the aerofoils. By means of such tail units or rudders, the lift generated by the tandem wing structure can be appropriately influenced, for example during acceleration to cruising speed and as a consequence thereof during successive throttling of the lifting rotors.

**[0035]** In an alternative embodiment, the support structure together with the wing structure can be configured as an elongate fuselage with only two transversely projecting aerofoils, similarly to a conventional aircraft. In this respect, one of the lifting rotors can be respectively arranged on each of the aerofoils and at least one further lifting rotor, preferably two further lifting rotors can be respectively arranged on the ends of the fuselage.

**[0036]** In a further alternative, the support structure together with the wing structure can be configured as a flying wing structure. In such a flying wing structure, the entire support structure and the entire wing structure are formed by a single aerofoil-shaped wing with inner, mechanically stabilizing supporting components. In this respect, the wing can have a swept form in a plan view. The lifting rotors and the thrust drive can be arranged in suitable regions of this type of flying wing structure.

**[0037]** Furthermore, it can be advantageous particularly in the case of an aircraft which is configured with this type of flying wing structure, but also in the case of the aircraft described above with a tandem wing structure or with a structure similar to a conventional aircraft, to expand the support structure around projecting nacelles to which the lifting rotors and/or the thrust drive can be attached.

**[0038]** Particularly in the case of an aircraft which is configured with a tandem wing structure as described above, but also in the case of other configurations of the support structure and of the wing structure, it can be advantageous or even compulsory to configure and arrange the lifting rotors and to select the wing structure such that the sum of the thrusts which can be generated by the lifting rotors passes substantially through a center of gravity of the aircraft and a neutral point of the wing structure relative to the center of gravity of the aircraft is suitably positioned for horizontal flight. A stable hover flight can be achieved by this type of arrangement of the lifting rotors. A stable flight state can also be achieved in aerodynamic flight at cruising speed by an appropriate configuration of the wing structure.

**[0039]** The lifting rotors of the aircraft can be configured to stop respective propeller blades of a lifting rotor in a particular rotational position. This stopping of the propeller blades can be particularly advantageous when the aircraft moves horizontally at a high cruising speed, driven by the thrust drive, and when the aerofoils of the wing structure generate enough dynamic lift so that it is unnecessary for any further lift to be generated by the lifting rotors. In a flight situation of this type, it is advantageous to stop the propeller blades of the lifting rotors in a rotational position such that on the one hand they generate the lowest possible air resistance while cruising, and on the other hand the lowest possible forces, acting horizontally and/or vertically on the propeller blades due to the air flowing past the blades, are generated.

**[0040]** The propeller of a lifting rotor can have, for example, exactly two blades. Such a propeller has on the one hand a high efficiency and on the other low imbalances. Furthermore, such a propeller with two blades is particularly advantageous for the proposed aircraft because, during a cruising position, it can be stopped in a rotational position



such that the propeller extends parallel to the direction of flight. The arrested propeller generates minimal air resistance in such a rotational position.

**[0041]** However, a single blade propeller can also be provided. On an end projecting beyond its rotor shaft, the single blade propeller has a weight which acts as a counter-weight to the single blade propeller. For example, the single blade propeller can be part of a lifting rotor of the aircraft which contributes towards the lift of the aircraft in the hover state. For the cruising state, the single blade propeller can be oriented parallel to an elongate nacelle, so that when stationary, the single blade propeller is oriented substantially parallel to the flight direction or to the longitudinal direction of the aircraft. The single blade propeller and the nacelle are then oriented in alignment with one another, which reduces the air resistance while the aircraft is cruising. In turn, the nacelle can be attached to one end of an aerofoil.

**[0042]** In the proposed aircraft, the lifting rotors and the thrust drive are preferably driven by motors which can be controlled independently of one another. Due to motors of this type which can be controlled separately from one another, in the aircraft, lift generated by the lifting rotors on the one hand and propulsion generated by the thrust drive on the other can be controlled independently of one another. In particular, rolling or yawing of the aircraft to be produced by the lifting rotors can be controlled independently of the horizontal propulsion to be produced by the thrust drive. In this respect, with an increasing cruising speed, the lifting rotors can also be controlled accordingly for a reduced lift generation to take into account the dynamic lift produced by the aerofoil of the wing structure.

**[0043]** Each of the lifting rotors can preferably be driven by an electric motor. Electric motors can be controlled precisely and quickly in respect of their rotational speed so that the lift generated by a lifting rotor can be varied quickly and precisely to initiate or control particular flight movements of the aircraft. Particularly in the case of an aircraft similar to a multicopter, the precise and rapid control of the vertical thrusts generated by the individual lifting rotors can be important for safe, stable and, if required, effortlessly maneuvered flight characteristics.

**[0044]** In a specific embodiment of the proposed aircraft, the thrust drive can be driven by an internal combustion engine and the internal combustion engine can also be coupled to a generator to supply electrical energy for the electric motors provided on the lifting rotors. In the case of such an aircraft provided with a type of hybrid drive, the thrust acting in the horizontal direction can be produced by the internal combustion engine of the thrust drive. The internal combustion engine can be realized as a piston motor or as a jet engine or the like. Fuel for an internal combustion engine of this type can be carried in the aircraft in adequate quantities so that the thrust drive can be operated for relatively long periods of time and the aircraft can thus fly at cruising speed for a lengthy period of time, for example in order to reach a remote target. However, unlike the thrust drive, the lifting rotors are preferably driven by electric motors in order to be able to use the simpler and more precise controllability compared to an internal combustion engine during hover flight or during take-off or landing. The electrical energy for these electric motors can be provided by the generator coupled to the internal combustion engine, it being possible for the electrical energy to either be supplied directly by the generator to the electric

motors or to be firstly stored in an electrical energy storage, such as in a battery, to then be released by the electric motors when required.

**[0045]** It is pointed out that possible features and advantages of the aircraft according to the invention are described herein with reference to different embodiments. A person skilled in the art will understand that the different features can be suitably combined or interchanged in order to arrive at further embodiments of the aircraft according to the invention.

**[0046]** In an alternative embodiment, the aircraft can have at least one aerofoil which is attached to the support structure such that it can swivel or rotate about a rotational axis. The rotational axis is oriented, for example, parallel to the vertical axis or to the yaw axis of the aircraft.

**[0047]** In an alternative embodiment, the aircraft has a second aerofoil which is attached to the support structure such that it can swivel about the rotational axis, the at least one aerofoil and the second aerofoil being in a swivelled-out state for hover flight.

**[0048]** Furthermore, the at least one aerofoil and the second aerofoil can be in a swivelled-in state for cruising, in which state leading edges of the aerofoils are oriented such that they are at least partly aligned with one another.

**[0049]** The support structure together with the wing structure can also be configured as a tandem wing structure with an elongate fuselage and two pairs of aerofoils which are arranged horizontally in tandem and project from the fuselage such that the first pair of aerofoils has a first sweep which differs from a second sweep of the second pair of aerofoils. In this respect, the sweep defines an angle between a transverse axis of the aircraft and the leading edge of the aerofoils.

**[0050]** In an alternative embodiment of the aircraft, the first pair of aerofoils and the second pair of aerofoils are connected by at least one connecting structure. The at least one connecting structure has an elongate form and is oriented parallel to the elongate fuselage. Furthermore, the at least one connecting structure can have a tail unit.

**[0051]** In an alternative embodiment, the first pair of aerofoils and the second pair of aerofoils are arranged vertically offset from one another. The vertical direction describes an axis parallel to the vertical axis or yaw axis of the aircraft and is oriented vertically, for example, to the transverse axis and to a longitudinal direction of the aircraft.

**[0052]** In a further alternative embodiment, the propellers of the lifting rotors are configured as single-blade propellers.

#### BRIEF DESCRIPTION OF THE DRAWINGS

**[0053]** In the following, embodiments of the present invention are described with reference to the accompanying drawings, although neither the drawings nor the description are to be construed as limiting the scope of the invention.

**[0054]** FIG. 1 is a perspective view of an aircraft according to the invention with a tandem wing structure.

**[0055]** FIG. 2 is a plan view of the aircraft from FIG. 1.

**[0056]** FIG. 3 is a perspective view of an aircraft according to the invention with forces acting thereon.

**[0057]** FIG. 4 shows a possible configuration of drives for an aircraft according to the invention.

**[0058]** FIG. 5 is a plan view of an aircraft according to the invention with two aerofoils in a swivelled-out state.

**[0059]** FIG. 6 is a plan view of an aircraft according to the invention with two aerofoils in a swivelled-in state.

[0060] FIG. 7 is a perspective view of an aircraft according to the invention with a tandem wing structure in which the aerofoils are swept.

[0061] FIG. 8 is a plan view of an aircraft according to the invention with a further tandem wing structure in which the aerofoils are swept.

[0062] FIG. 9 is a plan view of an aircraft according to the invention with six lifting rotors.

[0063] FIG. 10 is a plan view of an aircraft according to the invention with two mutually parallel elongate fuselages and two pairs of aerofoils on which lifting rotors are fitted.

[0064] FIG. 11 is a plan view of an aircraft according to the invention with two pairs of aerofoils and two mutually parallel elongate fuselages on which lifting rotors are fitted.

[0065] FIG. 12 is a perspective view of an aircraft according to the invention with a support structure which has two pairs of aerofoils with different sweeps.

[0066] FIG. 13 is a plan view of an aircraft according to the invention with a support structure which has two pairs of aerofoils with different sweeps.

[0067] FIG. 14 is a plan view of an aircraft according to the invention in which the fuselage is integrated into the aerofoils.

[0068] FIG. 15 is a plan view of an aircraft according to the invention with a support structure which has an elongate fuselage, a pair of aerofoils and lifting rotors attached to connecting elements.

[0069] FIG. 16 is a plan view of an aircraft according to the invention with a support structure which has an elongate fuselage, a pair of aerofoils and connecting elements which are arranged in the center of the aerofoils and to which lifting rotors are attached.

[0070] FIG. 17 is a perspective view of an aircraft with a support structure which has a fuselage, two pairs of aerofoils arranged in tandem in the longitudinal direction and two elongate connecting elements arranged parallel to the longitudinal direction.

[0071] FIG. 18 is a perspective view of an elongate nacelle, attached to an aerofoil, with a single-blade propeller.

[0072] The figures are merely schematic and are not true to scale. Identical reference signs in the figures identify identical or identically functioning features.

#### DESCRIPTION OF ADVANTAGEOUS EMBODIMENTS OF THE INVENTION

[0073] FIGS. 1 and 2 are a perspective view and a plan view of an aircraft 1 according to an embodiment of the present invention.

[0074] In the embodiment shown, the aircraft 1 has a tandem wing structure and, similarly to a quadcopter, one of four lifting rotors 5, fitted with a propeller 7, is arranged at both ends of each of the aerofoils 3. The lifting rotors are arranged on nacelles 6 at the ends of the aerofoils 3.

[0075] The aircraft 1 has a support structure 27 and a wing structure 15.

[0076] The support structure 27 provides the aircraft 1 with the necessary mechanical strength, for example, to transfer forces generated by the lifting rotors 5 or by the aerofoils 3 between individual regions of the aircraft 1. For this purpose, the support structure 27 has, for example, struts, stringers and formers which can form, inter alia, an elongate fuselage 13 as well as supporting parts of the aerofoils 3. The support structure can also be used to hold a camera system 30, for example,

[0077] The wing structure 15 forms, inter alia, the plurality of aerofoils 3 of the aircraft. Each of the aerofoils 3 of the wing structure 15 has a suitable profile to generate a lifting force onto the aircraft 1 by dynamic lift during horizontal motion of the aircraft 1.

[0078] In the example shown in FIGS. 1 and 2, the support structure 27 together with the wing structure 15 is formed as a tandem wing structure in which an elongate fuselage 13 is provided having two pairs of aerofoils 3 which are arranged horizontally in tandem and project transversely at the sides, approximately at a right angle from the fuselage 13.

[0079] The aerofoils 3 of the wing structure 15 are configured and attached to the fuselage 13 in suitable positions such that a neutral point of the wing structure 15 relative to a centre of gravity of the aircraft 1 is in a suitable position for horizontal flight of the aircraft 1. A neutral point of an aerofoil profile or of a wing structure having a plurality of aerofoil profiles can be understood as meaning a fixed point with constant torque in the region of moderate angles of incidence.

[0080] Tail units 21, 23 in the form of flaps or rudders which can be used as elevators or horizontal tails at high cruising speeds in the horizontal direction similarly to a conventional aircraft can also be provided both on the aerofoils of a front pair of aerofoils 3a and on the aerofoils of a rear pair of aerofoils 3b. Furthermore, a rudder unit or rudder 25 can be provided on the tail of the fuselage 13.

[0081] Provided at the ends or end regions of each of the aerofoils 3a, 3b is a respective lifting rotor 5 on a nacelle 6 so that the total of four lifting rotors 5 are arranged in a common plane and at the four corners of a virtual square.

[0082] Each of the lifting rotors 5 has a propeller 7 which can be driven in rotation by a rotor shaft 19 and a motor. The propeller 7 can be a rigid, preferably integral propeller so that a lift generated by the lifting rotor 5 can merely be varied by varying the rotational speed of the propeller 7. Alternatively, the propeller 7 can be a variable pitch propeller in which propeller blades 29 can be varied in pitch and, in this manner, lift generated by the lifting rotor 5 can be varied even at a constant rotational speed.

[0083] As shown in FIG. 3, each of the lifting rotors 5 is configured to generate a lifting force F1, F2, F3, F4. In this respect, the lifting rotors 5 should be positioned and oriented on the aircraft 1 such that the sum of the lifting forces generated thereby passes approximately through a center of gravity of the aircraft 1, particularly when all the lifting rotors 5 are operated uniformly at the same time. The thrust which can be generated overall by the lifting rotors 5 should be sufficient to lift the aircraft 1 and to allow it to hover. Some of the lifting rotors 5 rotate in opposite directions, as indicated by arrows in FIG. 3, so that the moments generated by the lifting rotors 5 substantially cancel each other out.

[0084] By varying the lifting forces F1, F2, F3, F4 generated by the individual lifting rotors 5, it is possible to vary the magnitude and direction of the total thrust which is generated overall and which acts on the aircraft 1, and in this manner the aircraft 1 can ascend or descend, can tilt forwards and backwards or to one side, or can rotate about a vertical axis of the aircraft, thereby making it possible to produce flight movements such as forwards flight, rolling and/or yawing.

[0085] Thus it is possible in principle with the proposed aircraft 1, similarly to a quadcopter, for all flight movements to be realized by appropriately controlling the various lifting

rotors 5. However, an achievable cruising speed at which the aircraft 1 can move horizontally is restricted here due to physical effects.

[0086] Therefore, to achieve high cruising speeds, the proposed aircraft 1 is additionally fitted with a thrust drive 9, by which a thrust F5 acting in the horizontal direction (see FIG. 3) can be produced.

[0087] In the example shown, the thrust drive 9 is formed by a thrust propeller 11, driven by an additional motor, and is arranged on the tail of the fuselage 13. However, the thrust drive 9 can also use other drive mechanisms, such as a jet engine. The thrust drive 9 should be adequately configured, i.e. it should allow adequate output power to enable the aircraft 1 to accelerate to high cruising speeds of, for example, up to 800 km/h.

[0088] In the aircraft 1 which has been accelerated by the thrust drive 9, an increasing dynamic lift is generated on the profiled aerofoils 3 as the cruising speed increases. This dynamic lift helps to hold the aircraft 1 in the air so that the lifting forces F1, F2, F3, F4 generated by the lifting rotors 5 can be successively reduced until the aircraft 1 has reached an adequately high cruising speed in the horizontal direction at which the total lift for the aircraft required to maintain the flight altitude is generated by the aerofoils 3.

[0089] The lifting rotors 5 can be stopped at such a cruising speed. It is provided in particular to stop the propellers 7 of the lifting rotors 5 in a position in which they generate the lowest possible air resistance and in which the lowest possible forces act on a propeller 7.

[0090] In the example shown, the propellers 7 are fitted merely with two blades 29 for this purpose, so that the linearly extending propeller 7 can be oriented with its blades 29 in the flight direction while cruising and can be stopped in this orientation. Alternatively, it would also be conceivable to retract the propeller 7 while cruising or, while cruising, to lower the propeller 7 or the entire lifting rotor 5, for example into a nacelle 17 provided on a respective end of an aerofoil to reduce the flow resistance.

[0091] FIG. 4 shows a possibility of an advantageous hybrid drive system for an aircraft 1 according to the invention.

[0092] Here, a main motor 31 is used to drive a thrust propeller 11. Thus, together with the thrust propeller 11, the main motor 31 forms the thrust drive 9 to generate the thrust F5 acting horizontally on the aircraft. The main motor 31 can be any type of motor capable of allowing sufficient power for horizontal flight at desired high cruising speeds. For example, the main motor 31 can be a diesel engine, a petrol engine, a Wankel engine, a gas turbine, a fuel cell-powered electric motor, etc.

[0093] In addition to the thrust propeller 11, the main motor 31 also drives an electrical generator 33. The generator 33 converts the mechanical drive energy provided by the main motor 31 into electrical energy and supplies this via lines 35 to a plurality of electric motors 37. The electric motors 37 are part of the lifting rotors 5, provided on the ends of the aerofoils, of the quadcopter-like aircraft 1. The electric motors 37 can respectively drive the propeller 7 attached thereto via a rotor shaft 19. The torque acting on the propeller 7 and thus the rotational speed assumed by the propeller 7 can be varied very precisely and quickly by the electric motor 37. To be able to electrically power and control the four electric motors 37, an electronic power control 39 is provided in the generator 33.

[0094] As an alternative to the hybrid drive system described above, the proposed aircraft 1 can also be operated by other drive systems. For example, the lifting rotors 5 can also be driven by internal combustion engines. Alternatively, it is possible to provide a central motor for the entire drive system and the plurality of lifting rotors can be coupled to this motor by power transmission shafts, it being optionally possible for couplings and/or gears to be provided in the associated drive trains. A lift to be generated by a lifting rotor 5 can be varied by changing the rotational speed and/or by changing an adjustable pitch of the propeller blades of the lifting rotor. Each of the lifting rotors 5 can also be driven by a separate electric motor, it being possible for the electric motors themselves to be driven by a main motor.

[0095] The described drive possibilities, such as the hybrid drive system, can be combined with all the embodiments described above and below. This is possible because in the described embodiments, at least one thrust drive 9 and at least three lifting rotors 5 are always provided.

[0096] FIG. 5 is a plan view of the aircraft 1 with a support structure 27 which has two aerofoils 3 which are swivellable relative to one another. In the configuration shown, the aircraft 1 is in a hover flight state 40 in which the aerofoils 3 are in a swivelled-out state. The aerofoils 3 are mounted such that they can swivel or rotate about a rotational axis 42. The rotational axis 42 is arranged, for example, parallel to the vertical axis and/or yaw axis of the aircraft 1 and passes through the elongate fuselage 13 of the aircraft 1. In a plan view, the aerofoils 3 respectively project beyond the elongate fuselage 13 so that the two aerofoils 3 intersect in the region of the rotational axis 42. In other words, the left aerofoil extends beyond the elongate fuselage 13 on the right-hand side of the aircraft 1 and the right aerofoil extends beyond the elongate fuselage 13 on the left-hand side of the aircraft 1. In this respect, it is to be borne in mind that the left aerofoil of the fuselage 13 means the aerofoil positioned on the left-hand side in the direction of flight, the direction of flight describing the horizontal direction in which the thrust of the thrust drive 9 acts with the thrust propeller 11. Analogously, the right aerofoil of the fuselage 13 means the aerofoil positioned on the right-hand side in the direction of flight. The part of the left aerofoil projecting on the right-hand side of the fuselage 13 can be smaller in terms of area than the part of the left aerofoil located on the left-hand side of the fuselage 13. Analogously, the part of the right aerofoil projecting on the left-hand side of the fuselage 13 can be smaller in terms of area than the part of the right aerofoil located on the right-hand side of the fuselage 13.

[0097] A wing leading edge 45 or aerofoil leading edge can be arranged inclined at a predetermined sweep angle  $\phi$  to a transverse axis 60 of the elongate fuselage 13. A person skilled in aircraft construction understands a transverse axis 60 as meaning an axis oriented vertically to the longitudinal direction 50 of the fuselage 13 and to the vertical axis of the aircraft. The sweep angle  $\phi$  is measured, for example, between the transverse axis 60 of the fuselage 13 and the leading edge 45 of the aerofoil 3. The sweep of the aerofoils 3 or the sweep angle  $\phi$  can be adapted, for example, to the flight speed of the aircraft 1 during horizontal flight. For this purpose, during the transition from a hover flight state 40 to a cruising state, which will be described in detail below, the sweep angle  $\phi$  can be continuously reduced. The arrows 44 show the movement of the aerofoils 3 during the transition from a hover flight state 40 into the cruising state, i.e. from the

swivelled-out state into a swivelled-in state. A locking of the aerofoils **3** in a particular sweep can be provided by an appropriate locking device for the aerofoils **3**. The transverse direction **60** of the elongate fuselage **13** can be oriented vertically to the rotational axis **42** and/or vertically to the horizontal direction. The horizontal direction is, for example, parallel to the longitudinal direction **50** of the elongate fuselage **13** of the aircraft **1**. The swivellable aerofoils each have two lifting rotors **5**, each of the lifting rotors **5** having a propeller **7**. In the swivelled-out state, the lifting rotors **5** are positioned and oriented on the aircraft **1** such that the sum of the lifting forces generated thereby passes approximately through the center of gravity of the aircraft **1**, particularly when all the lifting rotors **5** are operated uniformly at the same time. This allows a hover flight state **40** in which the aircraft **1** does not move, or moves only slightly, in the horizontal direction. For example, a lifting rotor **5** of the left aerofoil is fitted on the left-hand side of the fuselage **13** and a further lifting rotor **5** is fitted on the part of the left aerofoil projecting on the right-hand side of the fuselage **13**. Analogously, a lifting rotor **5** of the right aerofoil is fitted on the right-hand side of the fuselage **13** and a further lifting rotor **5** is fitted on the part of the right aerofoil projecting on the left-hand side of the fuselage **13**. During the transition from the hover flight state **40** to the cruising state, the rotational speed of the propellers **7** of the lifting rotors **5** can be continuously decelerated so that they are finally stationary in the cruising state.

**[0098]** FIG. **6** is a plan view of the aircraft **1** with a support structure **27** which has two aerofoils **3** which are swivellable relative to one another. In the configuration shown, the aircraft **1** is in the cruising state **41** in which the aerofoils **3** are in a swivelled-in state. In the cruising state **41**, the sweep angle  $\phi$  is smaller than in the hover flight state **40**. In the swivelled-in state, the leading edge **45** of the left aerofoil can be oriented to align with the leading edge of the part of the right aerofoil projecting over the fuselage **13**. Analogously, in the swivelled-in state, the leading edge **45** of the right aerofoil can be oriented to align with the leading edge of the part of the left aerofoil projecting over the fuselage **13**. In the swivelled-in state, the propellers **7** of the lifting rotors **5** are stationary and are oriented such that, in the cruising state **41**, they generate the lowest possible air resistance. For example, the elongate propellers **7** are then oriented in their longitudinal direction parallel to the horizontal direction or longitudinal direction **50** of the fuselage **13**.

**[0099]** The sweep angle  $\phi$  of the aerofoils **3** can be between 0 degrees and 90 degrees both in the swivelled-out state and in the swivelled-in state. A positive sweep is defined by a sweep angle  $\phi$  of more than 0 degrees. A negative sweep is defined by a sweep angle  $\phi$  of less than 0 degrees. If the sweep angle  $\phi$  is equal to 0 degrees, there is no sweep. In the aircraft **1** according to the invention, both positive and negative sweeps of the aerofoils **3** are possible. The aerofoils **3** can also be unswept. A positive sweep and a negative sweep can be provided in all embodiments described above and below.

**[0100]** FIG. **7** is a perspective view of the aircraft **1** with a tandem wing structure. In this respect, the elongate fuselage **13** and two pairs of aerofoils **3**, arranged horizontally in tandem and projecting from the fuselage **13**, are formed. The first pair of aerofoils **3a** has a negative sweep with a sweep angle  $\phi$  of between 0 and  $-90$  degrees and the second pair of aerofoils **3b** has a positive sweep with a sweep angle  $\phi$  of between 0 and 90 degrees. In the embodiment shown, the first pair of aerofoils **3a** is arranged in front of the second pair of

aerofoils **3b**, bearing in mind the flight direction, so that a plan view of the aircraft **1** gives the impression of an x-shaped arrangement of the first pair of aerofoils **3a** and of the second pair of aerofoils **3b**. The first pair of aerofoils **3a** and the second pair of aerofoils **3b** are interconnected by connecting structures **46**. In this respect, the right aerofoil of the first pair of aerofoils **3a** is connected to the right aerofoil of the second pair of aerofoils **3b** by a connecting structure **46**. Analogously, the left aerofoil of the first pair of aerofoils **3a** is connected to the left aerofoil of the second pair of aerofoils **3b** by a further connecting structure **46**. Thus, two connecting structures **46** are preferably provided, but it is possible to provide any number of connecting structures **46**. One connecting structure **46** can be attached, for example, to one end of the left aerofoil of the first pair of aerofoils **3a** and another connecting structure **46** can be attached, for example, to one end of the right aerofoil of the first pair of aerofoils **3a**. The connecting structures **46** can have an elongate form and can be oriented parallel to the longitudinal direction **50** of the fuselage **13**. The connecting structures **46** can also be interconnected by a tail unit **23**. The tail unit **23** is, for example, a rudder unit or a horizontal tail or a combination of rudder unit and horizontal tail. The connecting structures **46** can be arranged such that the aerofoils of the second pair of aerofoils **3b** intersect the connecting structures **46** and the aerofoils of the first pair of aerofoils **3a** end in the connecting structures **46**. Furthermore, the connecting structures **46** can have lifting rotors **5** with propellers **7**. In this case, two lifting rotors **5** are attached in each case to both connecting structures **46**. The lifting rotors **5** are positioned and oriented on the aircraft **1** such that the sum of the lifting forces generated thereby passes approximately through the center of gravity of the aircraft **1**, particularly when all the lifting rotors **5** are operated uniformly at the same time. A respective lifting rotor **5** is attached to the connecting structures **46** in the region of the first pair of aerofoils **3a** and a respective lifting rotor **5** is attached to the connecting structures **46** in the region of the second pair of aerofoils **3b**. Due to the arrangement of the lifting rotors **5**, the aircraft **1** can be brought into a hover flight state **40**. Bearing in mind the flight direction of the aircraft **1**, the connecting structures **46** can project to beyond the thrust drive **9** fitted to the fuselage **13**, where the two connecting structures **46** are interconnected by the tail unit **23**. Thus, the connecting structures **46** oriented in the longitudinal direction **50** are interconnected by the first pair of aerofoils **3a**, by the second pair of aerofoils **3b** and by the tail unit **23**. The connecting structures **46** thus have no direct contact with the fuselage **13**, but are connected thereto via the pairs of aerofoils.

**[0101]** FIG. **8** is a plan view of a configuration of the aircraft **1** in which the first pair of aerofoils **3a** is arranged in front of the second pair of aerofoils **3b**, bearing in mind the flight direction. The first pair of aerofoils **3a** has a positive sweep and the second pair of aerofoils **3b** has a negative sweep, so that the plan view gives the impression of an o-shaped arrangement of the first pair of aerofoils **3a** and of the second pair of aerofoils **3b** when the ends of each of the aerofoils are interconnected by connecting structures **46**. Thus, all the aerofoils **3** are connected at their ends to connecting structures **46**, so that two connecting structures **46** are oriented parallel to the longitudinal direction **50** of the fuselage **13**. A first connecting structure **46** connects the right aerofoils of the first pair and of the second pair of aerofoils **3a**, **3b**, and a second connecting structure **46** connects the left aerofoils of

the first pair and of the second pair of aerofoils **3a**, **3b**. The aerofoils can also each have tail units **23** and/or high lift systems, such as landing flaps. The two connecting structures can each have two ends on which a respective lifting rotor **5** is arranged. The four lifting rotors **5** are positioned and oriented on the aircraft **1** such that the sum of the lifting forces generated thereby passes approximately through the center of gravity of the aircraft **1**, particularly when all the lifting rotors **5** are operated uniformly at the same time, so that a hover flight state **40** of the aircraft **1** is possible.

[0102] FIG. 9 is a plan view of a configuration of the aircraft **1** with six lifting rotors **5**. For this purpose, the aircraft has one pair of aerofoils **3** and two connecting structures **46**, the connecting structures **46** being oriented parallel to the transverse axis **60** of the aircraft. Based on the flight direction of the aircraft **1**, the connecting structures **46** are arranged offset relative to one another so that one connecting structure **46** is arranged in front of the aerofoils **3** and one connecting structure **46** is arranged behind the aerofoils **3**. The connecting structures **46** can be provided, for example, with a profile which generates dynamic lift, so that the transverse arrangement of the connecting structures **46** provides the advantage of generating a lift by the connecting structures **46** in addition to the aerofoils **3**. The lifting rotors **5** are attached to the respective ends of the connecting structures **46** and aerofoils **3** oriented parallel to the transverse axis **60**. The six lifting rotors **5** are positioned and oriented such that the sum of the lifting forces generated thereby passes approximately through the center of gravity of the aircraft **1**, particularly when all the lifting rotors **5** are operated uniformly at the same time. As a result, the aircraft **1** can hover **40**. A thrust drive **9** can be provided on the tail for the propulsion of the aircraft **1** in the cruising state **41**. It can also be provided that the two connecting structures **46** are interconnected at their ends in each case by two further connecting elements **47**, in which case the two further connecting elements **47** are oriented parallel to the longitudinal axis **50** of the elongate fuselage **13** and vertically to the two connecting structures **46**.

[0103] FIG. 10 is a plan view of an aircraft **1** which has a support structure **27** with two mutually parallel elongate fuselages **13** and two pairs of aerofoils **3a**, **3b**, at the ends of which is attached a respective nacelle **6** with a respective lifting rotor **5**. The required lift can be generated by the lifting rotors **5** in a hover flight state **40**. The first pair of aerofoils **3a** is arranged in front of the second pair of aerofoils **3b**, bearing in mind the flight direction of the aircraft **1**. Furthermore, provided between the two fuselages **13** are two aerofoils **3c**, **3d** which are arranged offset relative to one another in the flight direction and which interconnect the two fuselages **13**. Like the two pairs of aerofoils **3a**, **3b**, the aerofoils **3c**, **3d** arranged between the fuselage **13** can have a profile which generates a dynamic lift. All the aerofoils of the aircraft **1** can be unswept in this case, i.e. they do not have a sweep. A thrust drive **9** for generating the propulsion of the aircraft **1** in the cruising state **41** can be attached to each of the two elongate fuselages **13** in the rear region of the fuselage **13**, i.e. on the tail, based on the flight direction. This means that one thrust drive **9** can be provided on the tail on each of the two fuselages **13**, so that the configuration shown here has two thrust drives **9**. High lift systems, for example landing flaps, can be provided on both pairs of aerofoils **3a**, **3b**.

[0104] FIG. 11 is a plan view of an aircraft **1** which has a support structure **27** with two mutually parallel elongate fuselages **13** and two pairs of aerofoils **3a**, **3b**. Furthermore, two

aerofoils **3c**, **3d**, arranged offset relative to one another in the flight direction are provided between the two fuselages **13** and they interconnect the two fuselages **13**. Like the two pairs of aerofoils **3a**, **3b**, the aerofoils **3c**, **3d** arranged between the fuselage **13** can also have a profile which generates a dynamic lift. Each of the two elongate fuselages **13** has two lifting rotors **5** arranged offset to one another along the longitudinal axis **50** of a fuselage **13**. For example, a respective lifting rotor **5** is attached to each end of the elongate fuselage **13**. Thus, overall, four lifting rotors **5** can be provided on the aircraft **1** which generate lift in a hover flight state **40**. It is possible to provide on one of the two aerofoils **3c**, **3d** arranged between the fuselage **13** a thrust drive **9** which generates a thrust in the cruising state. The thrust drive **9** is preferably arranged in the rear region, based on the flight direction, i.e. between the two tails of the fuselages **13** of the aircraft **1** on aerofoil **3d**. In this respect, the thrust drive **9** is arranged centrally between the two fuselages **13** to transfer the propulsion as uniformly as possible onto the aircraft **1**.

[0105] FIG. 12 is a perspective view of an aircraft **1** with a support structure **27** which has two pairs of aerofoils **3a**, **3b**, each of the two pairs of aerofoils **3a**, **3b** having a different sweep. The front pair of aerofoils **3a**, based on the flight direction, has a negative sweep and the rear pair of aerofoils **3b** has a positive sweep so that a plan view, as in FIG. 13, gives the impression of an x-shaped arrangement of the aerofoils **3a**, **3b**. However, it is pointed out that the two pairs of aerofoils **3a**, **3b** do not necessarily have to have the same wingspan or aspect ratio. For example, the rear pair of aerofoils **3b** has a greater wingspan than the front pair of aerofoils **3a** to thus achieve a higher aerodynamic efficiency. Likewise, the wing area of the rear pair of aerofoils **3b** can be greater than that of the front pair of aerofoils **3a** and vice versa. A nacelle **6** with a respective lifting rotor **5** can be attached to the ends of each aerofoil **3a**, **3b** so that when all the lifting rotors **5** are operated uniformly at the same time, the lifting forces generated thereby pass approximately through the center of gravity of the aircraft **1**. However, the nacelles **6** with the lifting rotors **5** do not necessarily have to be arranged at the ends of the pairs of aerofoils **3a**, **3b**. They can be provided in any position on or under the pairs of aerofoils **3a**, **3b**, for example also in the vicinity of the fuselage. Furthermore, the support structure **27** has an elongate fuselage **13** to which the two pairs of aerofoils **3a**, **3b** are attached so that the lift required for a hover flight state **40** can be generated. A thrust drive **9** is attached in the tail region of the aircraft **1** to generate propulsion in a cruising state **41**. The aerofoils **3a**, **3b** can be attached in the upper region of the fuselage **13**, based on a vertical axis or yaw axis of the aircraft **1**, so that during ground operation of the aircraft **1**, a relatively great distance is provided between the ground and the aerofoils **3a**, **3b**. As a result, the lifting rotors **5** can also be arranged under the aerofoils **3a**, **3b**. The aerofoils **3a**, **3b** can also be oriented anhedrally. A person skilled in aircraft construction understands the term "anhedrally" as meaning a negative V position of aerofoils **3a**, **3b** when viewed in the longitudinal direction **50** of the fuselage **13** or in the flight direction. This means that the aerofoils **3a**, **3b** are lowered from the fuselage **13** to their ends based on the vertical axis of the aircraft **1**. The maneuverability in particular of the aircraft **1** can be increased by a negative V position. Both a negative V position and a positive V position of the aerofoils can be provided in all the embodiments described above and below. In the positive V position, the aerofoils **3** ascend from the fuselage **13** to their ends based on the vertical axis of the

aircraft **1** so that a view in the longitudinal direction **50** gives the impression of a V shape of the aerofoils **3**. It is possible for the front pair of aerofoils **3a** to have a different wingspan compared to the rear pair of aerofoils **3b**. Consequently, a greater aerodynamic effectiveness can be achieved with a suitable arrangement of the aerofoils. For example, the front pair of aerofoils **3a** has a smaller wingspan than the rear pair of aerofoils **3b**. Furthermore, the front pair of aerofoils **3a** can be provided on the fuselage **13** at a different height along the vertical axis of the aircraft **1**. For example, the front pair of aerofoils **3a** is arranged higher on the fuselage **13** with respect to the vertical axis than the rear pair of aerofoils **3b**, as a result of which with a possible separation of the flow on the front pair of aerofoils **3b**, the rear pair of aerofoils **3b** continues to generate lift so that the aircraft **1** is able to perform an aerodynamically or mechanically stable flight.

**[0106]** In all the embodiments with a tandem wing structure, i.e. with two pairs of aerofoils, the first pair of aerofoils **3a** and the second pair of aerofoils can have a different wing area. A person skilled in aircraft construction understands “wing area” as meaning the area which is described by the wing outline, for example in a plan view.

**[0107]** FIG. **14** is a plan view of an aircraft **1** in which the fuselage **13** simultaneously forms the aerofoils **3**. This means that the fuselage **1** is integrated into the aerofoils **3**. This type of configuration is also known as a flying wing configuration. In a plan view of the aircraft **1**, the fuselage **13** or the aerofoils **3** have a delta shape or triangular shape. In other words, the trailing edge sweep of the aerofoils **3** is significantly smaller than the leading edge sweep. It is possible to provide on the fuselage **13** or on the aerofoils **3** four lifting rotors **5** which are arranged such that the aircraft **1** can be brought into a hover flight state **40**. In this respect, one lifting rotor **5** is attached to a front point and one lifting rotor **5** is attached to a rear edge of the fuselage **13**. Two further lifting rotors **5** are respectively attached to the two ends of the aerofoils in a wingspan direction of the aerofoils **3** or in a transverse direction **60** to the flight direction. To keep the aircraft **1** balanced during the hover flight state **40**, the lifting rotors **5** can be operated at different intensities. In other words, the thrust of each lifting rotor **5** can be adjusted individually so that in addition to allowing a balanced state during hover flight, a tilting of the aircraft **1**, for example about the longitudinal direction **50** or about a transverse axis **60** of the aircraft **1**, is also possible. Furthermore, a respective thrust drive **9** can be provided on each of the aerofoils **3**, said thrust drives **9** being attached to the respective leading edges of the aerofoils **3**. However, the thrust drives **9** can also be attached to the respective trailing edges of the aerofoils **3**. In any case, the thrust drives **9** are arranged such that propulsion is generated in the longitudinal direction **50** of the aircraft **1**.

**[0108]** FIG. **15** is a plan view of an aircraft **1** with a support structure **27**, the support structure **27** having an elongate fuselage **13**, a pair of aerofoils **3** and connecting elements **47**. The connecting elements **47** are fitted, for example as bar-shaped elements or beam-shaped elements, to the ends of the aerofoils **3** of the pair of aerofoils **3** and are oriented parallel to the longitudinal direction **50** or parallel to the elongate fuselage **13** of the aircraft **1**. Two lifting rotors **5** are respectively attached, offset relative to one another in the longitudinal direction **50**, to the connecting elements **47**, i.e. to the bar-shaped elements. Four lifting rotors **5** thereby generate

the corresponding lift for a hover flight state **40**. A thrust drive **9** for the propulsion of the aircraft **1** while cruising **41** is attached to the fuselage **13**.

**[0109]** As shown in FIG. **16**, instead of being attached to the ends of the aerofoils **3**, the connecting elements **47** can also be attached to approximately the center of each of the aerofoils **3**. In other words, a first connecting element **47** is attached, for example, parallel to the longitudinal direction **50** or parallel to the elongate fuselage **13** approximately centrally between the fuselage **13** and the end of the first aerofoil of the pair of aerofoils **3** such that a first end of the first connecting element **47** projects beyond the leading edge of the first aerofoil **3** and a second end of the first connecting element **47** projects beyond the trailing edge of the first aerofoil **3**. Correspondingly, a second connecting element **47** is attached parallel to the longitudinal direction **50** or parallel to the elongate fuselage **13** approximately centrally between the fuselage **13** and the end of the second aerofoil **3** of the pair of aerofoils **3** such that a first end of the second connecting element **47** projects beyond the leading edge of the second aerofoil **3** and a second end of the second connecting element **47** projects beyond the trailing edge of the second aerofoil **3**. Two lifting rotors **5** are respectively attached, being offset relative to one another in the longitudinal direction **50**, to the connecting elements **47**, i.e. to the bar-shaped or beam-shaped elements. These lifting rotors **5** are attached, for example, to the respective ends, projecting beyond the aerofoils **3**, of the two connecting elements **47** so that the lifting rotors **5** are not located above the aerofoils **3**, but they project beyond them along the longitudinal direction **50** of the fuselage **13**. The region above the aerofoils **3** describes the region over the aerofoils **3** in respect of the vertical axis usually used in aircraft construction.

**[0110]** FIG. **17** is a perspective view of an aircraft **1** with a support structure **27**, comprising a fuselage **13**, two pairs of aerofoils **3a**, **3b** arranged in tandem in the longitudinal direction **50**, and two elongate or bar-shaped connecting elements **47** arranged parallel to the longitudinal direction **50**. The pair of aerofoils **3a** attached in the front region of the elongate fuselage **13** with respect to the flight direction or the longitudinal direction **50** has a positive sweep, whereas the pair of aerofoils **3b** attached in the rear region of the elongate fuselage **13** does not have a sweep or has a smaller sweep compared to the sweep of the pair of aerofoils **3a** attached in the front region of the elongate fuselage **13**. For example, the sweep of the first pair of aerofoils **3a** is between 20 and 30 degrees. The pairs of aerofoils **3a**, **3b** can be attached to the fuselage **13** at different heights with respect to the vertical axis of the aircraft **1**. In other words, this means that to an observer who is looking in the longitudinal direction **50** or in the flight direction of the aircraft **1**, the first pair of aerofoils **3a** is arranged under the second pair of aerofoils **3b**. The aerofoils of the two pairs of aerofoils **3a**, **3b** are thus arranged offset along the vertical axis of the aircraft **1**. Four connecting elements **47** are attached to the respective ends of the aerofoils **3a**, **3b**, which connecting elements extend parallel to the longitudinal direction **50** of the fuselage **13**. Since the aerofoils **3a**, **3b** are attached to the fuselage **13** at different heights along the vertical axis on a first side of the fuselage, for example on the left fuselage side, the connecting elements **47** which are attached to the ends of the aerofoils **3a**, **3b** on the left fuselage side are also located at different heights. In this respect, a connecting piece **48** can be provided which interconnects the connecting elements **47** on one side of the fuselage. The connecting piece **48** can be a plate-shaped or disc-

shaped component which comprises a tail unit **23** in particular, such as the rudder unit of the aircraft **1**. The height difference between the two pairs of aerofoils **3a**, **3b**, which results in respect of the vertical axis, can be bridged by the provision of the connecting piece **48** to accommodate the rudder unit. Lifting rotors **5** are again respectively provided on the connecting elements **47**. One lifting rotor **5** is attached to each of the four connecting elements **47**. Two lifting rotors **5**, offset relative to one another in the longitudinal direction **50**, are thus positioned and oriented on both sides of the elongate fuselage **13** such that a sum of the lifting forces generated by the lifting rotors passes approximately through a center of gravity of the aircraft **1**, particularly when all the lifting rotors **5** are operated uniformly at the same time. Furthermore, a thrust drive **9** to generate the propulsion of the aircraft **1** is provided in the tail region of the elongate fuselage **13**.

[0111] FIG. **18** is a perspective view of an elongate nacelle **6** with a single-blade propeller **7a**. This view also shows a rotational direction **70** of the single-blade propeller **7a**. The single-blade propeller **7a** has on an end projecting beyond its rotor shaft **19** a weight **7b** which acts as a counter-weight to the single-blade propeller. Thus, the single-blade propeller **7a** has a first portion between the weight **7b** and the rotor shaft **19** and a second portion between the end of the blade of the single-blade propeller **7a** and the rotor shaft **19**. Both portions of the single-blade propeller **7a** are therefore on different sides of the rotor shaft **19**. The length of the first portion of the single-blade propeller **7a** measures, for example, between a quarter and a third of the overall length of the single-blade propeller **7a**, whereas the length of the second portion of the single-blade propeller **7a** measures between two-thirds and three-quarters of the overall length of the single-blade propeller **7a**. The single-blade propeller **7a** can be, for example, part of a lifting rotor **5** of the aircraft **1** which contributes towards the lift of the aircraft **1** for a hover flight state **40**. The single-blade propeller **7a** can be brought into a parallel orientation to the elongate nacelle **6** for a cruising state **41**, so that when stationary, the single-blade propeller **7a** is oriented substantially parallel to the flight direction or to the longitudinal direction **50** of the aircraft **1**. The single-blade propeller **7a** and the nacelle **6** are then oriented in alignment with one another, which reduces the air resistance while the aircraft **1** is cruising. In turn, the nacelle **6** can be attached to one end of an aerofoil **3**. In a cruising state, the lift can be generated by an aerofoil **3** provided with a profile which generates a dynamic lift. Propulsion is ensured by a thrust drive not shown in FIG. **18**. The single-blade propeller **7a** shown in FIG. **18** can be used in all the previously described embodiments, for example as part of a lifting rotor **5**.

[0112] Two propellers can also be arranged one above the other. This applies to single-blade propellers and to double-blade propellers or multi-blade propellers. During hover flight, the lower propeller can rotate, for example, in the same and/or in the opposite rotational direction as the upper propeller. The angular momentum can be reduced by an opposite rotational direction. Two superimposed propellers each with its own motor can also be provided, thereby making it possible to increase redundancy and thus safety. If one motor fails, the aircraft **1** could continue to hover. In a further embodiment, it can be provided that the propellers can be stowed behind an aerodynamic casing, for example by moving into the nacelle **6**, so that the resistance can be further

reduced. For this purpose, for example, flaps can be provided on the nacelles **6** which can be closed after the propeller has moved into the nacelles **6**.

[0113] In a further embodiment, the propeller can be mounted in an articulated manner. This can be advantageous particularly during forwards flight of the aircraft **1**, since rolling moments due to an asymmetrical flow on the propellers are not transferred thereby onto the aircraft **1**. Furthermore, bending moments arising in the propeller blade would stress the motor hub to a lesser extent, because the bending moments would remain in the blade. This applies both to a double-blade propeller and to a single-blade propeller.

[0114] Embodiments of the proposed aircraft **1** can be configured with a very lightweight structure, particularly compared to conventional aircraft capable of vertical take-off, and at the same time they can allow high cruising speeds. The multicopter-like configuration with a plurality of lifting rotors can allow a simple and efficient hover flight mode. Furthermore, it is easily possible to change from a vertical to a horizontal flight mode. The controls and control algorithms proposed for this purpose can be configured relatively simply. The proposed aircraft concept can be implemented with simple, economical and robust drive motors and power transmission mechanisms. For example, the lifting rotors can be operated by simple electric motors, only the speed of which has to be controlled. The thrust drive can be driven by any type of simple motor and, compared to conventional aircraft, can have a substantially lower power, since in particular the horizontal maximum thrusts required for the take-off of an aircraft do not have to be delivered. Overall, the proposed aircraft can have a high payload capacity.

**1-24.** (canceled)

**25.** An aircraft, comprising:

a support structure;

a wing structure;

at least three lifting rotors; and

at least one thrust drive;

wherein the wing structure is attached to the support structure or is part of the support structure,

wherein the wing structure is configured to generate a lifting force for the aircraft during horizontal motion of the aircraft using at least one aerofoil which is provided with a profile generating a dynamic lift,

wherein each of the at least three lifting rotors is attached to the support structure, has a propeller and is configured to rotate the propeller to generate a lifting force, acting in the vertical direction, for the aircraft,

wherein the propeller of each of the at least three lifting rotors has exactly two propeller blades, and

wherein the at least one thrust drive is configured to generate a thrust force, acting in the horizontal direction, on the support structure.

**26.** The aircraft according to claim **25**, wherein the support structure, together with the wing structure, is configured as a tandem wing structure with an elongate fuselage and two pairs, arranged horizontally in tandem, of aerofoils which project transversely from the fuselage.

**27.** The aircraft according to claim **26**, wherein one of the at least three lifting rotors is respectively arranged on each of the at least one aerofoil.

**28.** The aircraft according to claim **26**, further comprising a nacelle, arranged on each of the at least one aerofoil, on which one of the at least three lifting rotors is respectively arranged.

**29.** The aircraft according to claim **26**, wherein a tail unit is arranged on each of the aerofoils.

**30.** The aircraft according to claim **25**, wherein the at least three lifting rotors are configured such that a plane of rotation in which the propeller blades of a respective lifting rotor rotate is stationary relative to a motor-driven rotor shaft of the respective lifting rotor.

**31.** The aircraft according to claim **30**, wherein the propeller blades of the respective lifting rotor are rigidly connected to the motor-driven rotor shaft.

**32.** Aircraft according to claim **30**, wherein the propeller blades of the respective lifting rotor are swivelably connected to the motor-driven rotor shaft such that a pitch of the propeller blades can be varied.

**33.** The aircraft according claim **25**, having at least four lifting rotors.

**34.** The aircraft according to claim **25**, wherein the sum of the lifting forces which can be generated by the at least three lifting rotors passes substantially through a center of gravity of the aircraft; and

wherein a neutral point of the wing structure relative to the center of gravity of the aircraft can be suitably positioned for a horizontal flight.

**35.** The aircraft according to claim **25**, wherein the at least three lifting rotors are each configured to stop respective propeller blades of a respective lifting rotor in a position relative to the support structure.

**36.** The Aircraft according to claim **25**, wherein the at least three lifting rotors and the thrust drive are driven by motors which are controllable independently of one another.

**37.** The aircraft according to claim **25**, wherein each of the at least three lifting rotors is driven by an electric motor.

**38.** The aircraft according to claim **37**, wherein the thrust drive is driven by an internal combustion engine and the internal combustion engine is coupled to a generator to provide electrical energy to the electric motors of the at least three lifting rotors.

**39.** The aircraft according to claim **25**, wherein the at least one aerofoil is attached to the support structure such that it is swivelable about a rotational axis.

**40.** The aircraft according to claim **39**, wherein a second aerofoil is attached to the support structure such that it is swivelable about the rotational axis, and wherein the at least one aerofoil and the second aerofoil are in a swivelled-out state for hover flight.

**41.** The aircraft according to claim **40**, wherein the at least one aerofoil and the second aerofoil are in a swivelled-in state for cruising in which leading edges of the aerofoils are oriented in alignment with one another.

**42.** The aircraft according to claim **25**, wherein the support structure together with the wing structure is configured as a tandem wing structure with an elongate fuselage and two pairs of aerofoils which are arranged horizontally in tandem and project from the fuselage.

**43.** The aircraft according to claim **42**, wherein the first pair of aerofoils has a first sweep which differs from a second sweep of the second pair of aerofoils.

**44.** The aircraft according to claim **42**, wherein the first pair of aerofoils and the second pair of aerofoils are connected by at least one connecting structure.

**45.** The aircraft according to claim **44**, wherein the at least one connecting structure has an elongate form and is oriented parallel to the elongate fuselage, and wherein the at least one connecting structure has a tail unit.

**46.** The aircraft according to claim **42**, wherein the first pair of aerofoils and the second pair of aerofoils are arranged offset relative to one another in a vertical direction.

**47.** The aircraft according to claim **25**, wherein the propellers of the lifting rotors are configured as single-blade propellers.

\* \* \* \* \*